

Military Historical Society of Australia
Sabretache



Copyright © 1957-2019 Military Historical Society of Australia on behalf of the Society and its authors who retain copyright of all their published material and articles. All Rights Reserved.

Sabretache policy is that the submission of material gives the Society permission to print your material, to allow the material to be included in digital databases such as the MHSa website, Australian Public Affairs-Full Text, INFORMIT and EBSCO. Reprints to non-profit historical and other societies will be approved provided suitable attribution is included and a copy of the reprint is sent to the author. Copyright remains with the author who may reprint his or her article or material from the article without seeking permission from the Society.

The Society encourages the download and distribution of *Sabretache* for personal use only and *Sabretache* can not be reproduced without the written consent of the Society.

www.mhsa.org.au

Military Historical Society of Australia
PO Box 5030, Garran, ACT 2605.
email: webmaster@mhsa.org.au

GEORGE CLARKE: THE FABULOUS KINDUR AND BUSHRANGERS

David Murphy¹

On 29 April 1825, George Clarke, one of 135 male convicts, arrived at Port Jackson, Sydney, NSW aboard the *Royal Charlotte* commanded by Master G C Corbyn. The ship had sailed from Portsmouth on 5 January 1825.

A week later on 5 May 1825, the Superintendent of Convicts and his staff performed a muster of those on board to find that one convict had committed suicide during the passage. During the muster every convict was examined and compared to the list received at Portsmouth by Surgeon Superintendent, George Fairfowl, who was responsible for the health and conditions of both convicts and crew during the passage. When Clarke was examined he appeared indifferent to what was happening. He was nearly 6 feet tall, with a pale complexion, brown hair and chestnut eyes. A hairdresser by trade, his alias was George the Barber. His age was given as 21 years.

Little is known about Clarke's life in England. He was tried at Shrewsbury on 24 August 1824, found guilty and sentenced for transportation to NSW where he was to serve his life sentence. Following his trial he was held in the local jail before being sent to London to be imprisoned aboard HMS *Justitia*. A few months later he joined the *Royal Charlotte* for transportation to NSW. From London the ship sailed to Portsmouth for repairs before continuing on its voyage. On arriving in Sydney, Clarke was assigned to Benjamin Singleton at Patrick's Plains (later known as Singleton, about 200 kilometres south of Tamworth). He absconded in early 1826.

Five years later in November 1831, practically naked, Clarke was found living as the leader of a tribe of Aborigines. He was captured near present day Boggabri (100 kilometres northwest of Tamworth) by a party of Mounted Police led by Sergeant John Wilcox, assisted by Aboriginal trackers. When Clarke arrived at Bathurst, he was interrogated by Ensign Lauderdale Maule, 39th Regiment, who commanded the Mounted Police post. Clarke said he had learnt the Aboriginal language and customs. He had taught the natives to herd stock and how to keep them in a safe stockyard for later slaughter rather than spearing them, taking what they wanted and leaving the remains where they fell. Clarke then told of a fabulous river called the Kindur that flowed to the northwest from somewhere close to where he was captured. He claimed that about a year after he arrived on the plains he heard that a white man was in the area and to avoid capture moved north following the Kindur.² He said he followed the river all the way to the sea where he bathed in the salty waters before returning to the location where he was eventually captured.

Clarke also told of a bushranger's hideout or haunt, at a place he called Guaramei.

Mitchell Expedition

Maule notified the Acting Governor and Commanding Officer of the 39th Regiment, Patrick Lindesay who immediately instructed the Surveyor General, Thomas Mitchell, to try and find this river.³ The expedition set out on 21 November 1831, and travelled by way of

¹ This article was submitted by the late David Murphy shortly before his death in February 2009. David was a long-time member of the Society with a great interest in the 17th Regiment and the Mounted Police. His first article on the 17th Regiment in *Sabretache* was published in 1989.

² This may have been explorer Allan Cunningham on his expedition of 1827–1828.

³ At this time Mitchell was under a cloud waiting for the arrival of the incoming Governor Richard Bourke. Governor Darling had written to London requesting that Mitchell be dismissed from his position, due to misconduct in his department.

Parramatta, Wiseman's and to the east of the Liverpool ranges, but west of Scone to the present day region of Tamworth. Mitchell includes the story of this expedition in *Three expeditions*.

Mitchell returned to Sydney in early March 1832 and interviewed Clarke onboard the *Hulk* where he had been placed to await Mitchell's return. Following his trial in early February, Clarke was sentenced to death but the sentence was remitted to transportation in irons to Norfolk Island for a period of three years. Clarke admitted he had not gone further than the Nandewar Ranges (100 kilometres north of Tamworth). Reporting his findings to Governor Bourke, Mitchell claimed that there was no river flowing to the northwest but he had noticed that all the rivers joined the Darling system which turned to the south, probably emptying into the Southern Ocean.

Bushranger's hideout at Guaramei

Governor Bourke instructed Captain John Douglas Forbes, 39th Regiment, Commanding the Mounted Police, to search for the haunt of bushrangers said to be at Guaramei, but instead of taking the route travelled by Mitchell, he was to closely follow the route that the Mounted Police had taken when they captured Clarke in November 1831.

The expedition commenced on Sunday, 25 March 1832, the first four days were taken up in preparations and paperwork. On 29 March, Forbes, accompanied by Lieutenant C W Finch, 17th Regiment, set out for Bathurst, arriving the following day. They remained for four days while Forbes discussed the expedition with Ensign Maule and selected most of the troopers stationed there to join the expedition. In addition to Forbes and Finch, the party was made up of Ensign Maule, Sergeants Wilcox and Higgins, Corporals Temple and Kielty and about seven or eight troopers that included Hurst and Herbert, their horses, a cart and some pack horses.

The expedition set out on 4 April for the Cudgegong River and by 7 April was 72 miles (115 kilometres) from Bathurst. They continued via Gulgon or Royall Creek and thence to Slapdash, an old stockyard and onto Lawson's Station on the Talbragar River. There Forbes had a good view of the ranges to the northwest, which he named the Wallumbangle's after consulting with his Aboriginal guides.⁴ The party probably crossed the southern part of these ranges sighting Weetaliba as they travelled the Coolah Valley, crossing the Liverpool Ranges to the west of Pandora Pass, gaining Noubrei Creek, and onto the Mullaley area, losing one day due to rain. By 14 April, the end of week 3, the party had travelled 200 miles (320 kilometres).

Forbes made good use of his Aboriginal guides and trackers, using Aboriginal terms for ranges, mountains, creeks and other areas of interest as per Mitchell's instructions to his surveyors. The guides and trackers came and went as they liked throughout the expedition, which caused Forbes some frustration. During the 4th week at Noubrei, torrential rain limited travel to just two days. Because of the condition of some of the horses, Forbes sent Sergeant Higgins, Trooper Hurst and one other trooper back to Bathurst, via Wellington Valley.

Week 5 was just as bad as the previous week with only 23 miles (37 kilometres) covered and another five days lost. By 28 April, the party was 245 miles (400 kilometres) from Bathurst. On 27 April one of the guides, Liverpool, King of the Eurambone tribe, drew a wawee in Forbes's field book, terrifying the other guides. The wawee was a creature that seemed to inhabit the creeks and rivers of the district now known as the Pilliga Scrub. Some said it was a Pilliga Yowie. Forbes thought it was a walrus type of species, while it seemed to be a seal found in the Nammoy and Gwydir Rivers.

The expedition continued more easily the following week. Only one day was lost when the party waited for the return of Corporal Temple who had escorted the cart as far as Noubrei, since it

⁴ Now known as the Warrumbungles.

would have been unable to cross the swampy plains following the rain of the previous two weeks. The cart was sent back to Bathurst carrying letters for Sydney. The party arrived at the Nammoy River on 29 April and followed its course to the northwest for the next three days, looking for a suitable place to cross. One of the men was a good swimmer and swam across the river with a line, tied it off and returned. Getting the horses across the river went easily until a horse named Cogador decided it was going no further. No amount of cajoling or whipping would get the horse to move. The horse was left standing in the river with only its head above water. After having some tea, or as Sergeant Wilcox called it, 'the staff of life in the bush', Finch went back to see if he could get the horse out of the river. Assisted by the level of the river slowly dropping and by reducing the gradient of the bank, nearly eight hours later he finally coaxed the horse to the northern bank.

Forbes had been noting latitude and longitudes but in week 6 he lost his compass, but was able to continue his notes by using the small compass Finch had brought with him.⁵ The Aboriginal guides deserted but returned by Friday 4 May, bringing with them some women and children. All of them recognised the name of Clarke as George the Barber and seemed to hold him in awe. By 5 May, the end of week 6, the party was at Bandamoule, 320 miles (510 kilometres) from Bathurst. The party continued to the northwest by following the Nammoy to their left. Seeing horse tracks heading off into the mountains, Forbes and Finch followed the tracks hoping it would lead them to Guaramei. The tracks petered out, leaving them a little depressed and wondering if they would ever find the bushrangers. The way the tracks meandered under trees made Forbes think that the tracks belonged to stray horses lost by the bushrangers. He decided to backtrack and see if that would lead them to the hideout, but again the tracks disappeared.

Late one night, the sentry gave an alarm to say that different natives were swarming down the hills towards the campsite. This was probably the reason the guides suddenly disappeared again. The party was surrounded but on the alert. The new group was led by a very tall Aborigine who walked towards the camp in a friendly manner. The next morning the party broke camp and was for a short time followed by the tall Aborigine before the party proceeded on their own, towards the Gwydir. In the scrub Forbes lost his small telescope but the party went on to reach the banks of the Gwydir, probably near Walgett. The river at this point was 25 metres wide and Forbes thought it was the most magnificent river in NSW. The party remained there for several days. Corporal Temple found a two-bladed penknife, giving hope that they were close to the bushranger's hideout at Guaramei. They ate well on cod and snake. By 12 May, the end of week 7, they reached what Forbes thought was the Drummond Ranges. They had now travelled some 444 miles (710 kilometres) from Bathurst.

The following week was spent looking for tracks that might lead them to Guaramei. They soon came across cattle tracks but again these petered out. That week food was scarcer, no meat or fish, only damper and tea and the creek they were following was now dry. Forbes searched for the Lindsay Ranges without avail, but found Oxley's Horton River. Forbes began to lose hope of finding the hideout. Continuing on, they came to Stoddart's Valley. By 19 May, the end of week 8, they were 530 miles (850 kilometres) from Bathurst.

Forbes now decided to turn back for home and the expedition returned a slightly different direction to the way they had come. It was closer to Mitchell's route earlier that year along the Nandewar Range. Before heading for Pewen Bewen near Scone, they stopped at Onn's Station where they left Maule and the troopers to rest and to let one of the horses recover before returning to Bathurst. Forbes and Finch continued to Pewen Bewen. By 26 May, the end of week 9, Forbes and Finch had travelled 818 miles (1310 kilometres) from Sydney and 664 miles

⁵ As was normal for nearly all explorers of the time, the readings were far from accurate.

(1060 kilometres) from Bathurst. From there they continued on to Jerry's Plains where they read a report in the *Sydney Gazette* that the expedition was lost and all men killed by wild natives.

From Jerry's Plains Forbes and Finch made their way to Wallis Plains where there was a Mounted Police post. There they talked to Lieutenant Isaac Blackburn, 17th Regiment, the Mounted Police subaltern in command, and stayed the night. For the first time since leaving Bathurst they slept in a bed. They had now travelled a total of 922 miles (1590 kilometres) from Sydney on horseback. Early the following morning, Wednesday, 30 May, they boarded the steamer *Sophia Jane* for the trip back to Sydney. They sailed via Newcastle where they were delayed for several hours, and tied up in Sydney Harbour in the early hours of 31 May, having been away nine weeks. Forbes reported to his Commanding Officer Patrick Lindesay and both men went to see Governor Bourke. They informed him that the expedition had been unable to find the bushrangers' hideout but were able to confirm some of Mitchell's notes from his expedition.⁶

Forbes ate native food on his journey including snake, opossum, birds, kangaroo, eel-tailed catfish (*Tandanus, Tandanus*), which he found to be muddy and tough. He also ate beef, plenty of damper and tea, sometimes with a sweetener such as honey or sugar. In many instances the expedition was short of fresh water and Forbes stated at one time he drank his dogs' blood to avoid dying of thirst.

Forbes settled back into work and continued his duty as Mounted Police Commandant but this was short-lived. His regiment was ordered to proceed to India. He left with the regiment in mid July 1832, and was never to return to Australia. Sadly, on his return home to England from India in July 1836, on board the ship *Protector*, he died of dysentery and liver disease. He was 33 years old, having been born in London in 1803. All his personal uniforms were auctioned off but his diaries were left to the Regimental Museum, including two of his three journals from his exploration.

Conclusion

During their expedition neither Mitchell nor Forbes found anything of importance, other than to confirm other explorers' discoveries. Mitchell continued as Surveyor General and made another three expeditions, his last expedition was to tropical Queensland in 1845. Clarke, who had been imprisoned on Norfolk Island, returned to Sydney in 1833 and was transported to Van Diem's Land by the brig *Siren* on 1 January 1835. Following an escape attempt he was hanged in August 1835.

References

Historical Records of Australia, Vol XXIV, Governors Despatches, Acting Governor Patrick Lindesay to Viscount Goderich, November 1831; State Records of NSW, Convict details Transport ship *Royal Charlotte* 5 May 1825, Muster.

Thomas Mitchell. *Three expeditions into the interior of eastern Australia: with descriptions of the recently explored region of Australia Felix, and of the present colony of New South Wales*, Eagle Press, 1996, 2 v. ISBN 0646254421 (set).

Charles Bateson. *The convict ships, 1787–1868*, 1988 edition.

Northern Territory News, 27 November 1969, page 20.

W Allan Wood. *Dawn in the valley: the story of settlement in the Hunter River Valley to 1833*, Sydney, Wentworth Books, 1972, ISBN 0855870273.

Dean Boyce. *Clarke of the Kindur*, MUP 1970.

⁶ Mitchell freely acknowledged Forbes in his book on the search of the *Kindur* and has even named a mountain after him, Mt Douglas Forbes in the Nandewar Range.

TWO OF A KIND: THE LONG CHAMBERED MAXIM-NORDENFELT 14 POUNDER QUICK FIRING GUNS

John Rogers¹

In order to improve the protection of Port Phillip Bay in the 1880s, the fleet of eight permanent Victorian Navy vessels was doubled by modifying Government and Harbour Trust vessels. These vessels, with locally invented torpedo dropping gear, strengthened decks and magazines, etc, could then be quickly fitted as gunboats and torpedo boats in an emergency. In addition, for troop transport and scouting outside of the protected waters of Port Phillip Bay, modifications were made to large merchant vessels so that Quick Firing (Q.F.) guns could be mounted.

The Guns

To this end, two Maxim-Nordenfelt 14 pounder (pdr) Q.F. guns were acquired by the Colony of Victoria in 1889.² These guns were originally intended to arm the Bay Steamer, SS *Courier*, for emergency situations.³ In April 1891, it was reported that two long chambered Maxim-Nordenfelt 14 pdr Q.F. guns were in use at Fort Queenscliff.⁴ Most likely the suitability of this type of gun for possible use at the Fort was being tested while they were not required on board *Courier*.

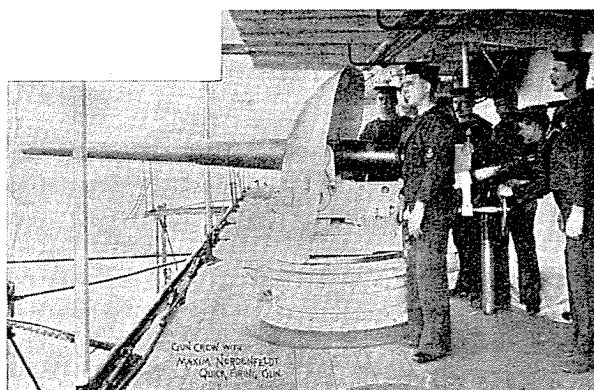

One of the 14 pdrs on board HMVS *Cerberus* in 1900
(note shell standing vertical behind the gun).
Weekly Times, 14 July 1900.

When five more 14 pdrs, presumably Mk I guns, were obtained for the LandForces, the two long chambered guns were handed back to the navy.⁵ Both guns were then mounted on board HMVS *Nelson*. It would appear that only a small amount of ammunition was held on board *Nelson*, as it was stated that the Q.F. magazine on board HMVS *Cerberus* was: 'also used for the stowage of the ammunition for the 14 pdr Q.F. guns on the *Nelson*.'⁶ On the sale of *Nelson* both guns were transferred to *Cerberus* in July 1897. These guns were mounted on the breastwork deck, one on the port side and one on the starboard side of the ship.

- 1 John.Rogers@cerberus.com.au is President of *Friends of the Cerberus* and is keen to learn of any further details on the 14 pdr guns and ammunition used in Victoria.
- 2 'The Victorian Government have ordered two 14pdr quick-firing guns, having a muzzle velocity of 2050 ft. per second, and firing 12 aimed shots per minute.' *The Argus*, 11 May 1889.
- 3 '2-14 pdr guns in the colony ordered for the armament of "The Courier" it is proposed to hand over to Military charge for mounting at Queenscliff; and to allot 2 of the 5 on order to the Navy instead. *Distribution of Land Forces Guns, 1892*. Courtesy of John Underwood.
- 4 *The Argus*, 6 April 1891.
- 5 'Note the 2 long chambered 14 pdr are now on Naval charge.' Hand written note on *Distribution of Land Forces Guns, 1892*.
- 6 *Manual for Victorian Naval Forces - 1890*, courtesy of Melbourne University Library.

In 1900, the Victorian Government offered the British Government a Naval Contingent to assist in suppressing the Boxer Uprising in China. Use of the 14 pdrs from the *Cerberus* was also offered. Engineer William George Robertson (Victorian Navy) designed and superintended the construction of gun carriages, limbers and ammunition wagons at the Newport Railway Workshops (Victoria) over a period of 7 days.⁷ The guns then accompanied the Victorian Naval Contingent to China. In Hong Kong, the 14 pdrs were swapped for 12 pdrs which had the advantage of being lighter and easier to obtain ammunition for. Given that on 22 December 1901 the 14 pdr ammunition on board *Cerberus* was transhipped into the Army launch, *Vulcan*, for transfer to the Military Department,⁸ we can assume that the guns did not return from Hong Kong.



Testing of the 14 pounder guns prior to leaving for China.⁹

The Ammunition

When asked about the ammunition for the two guns which the contingent were likely to take with them (to China) – ‘the only guns of their class in the British Empire’ – a spokesman for the Victorian Minister for Defence answered: ‘these two guns were specially made for exhibition purposes, and that such alterations were made in the guns subsequently manufactured that the same ammunition will not do’.¹⁰ Presumably the two guns in question were made as prototypes for the company’s new 14 pdr Q.F. guns. Subsequent modifications to both the configuration of the ammunition, the size of the guns’ chambers and a longer barrel led to the Mk I gun, which was then incompatible with the prototype guns. The two prototype guns, which ended up on the *Cerberus*, were most likely purchased by the Victorian Government’s Agent General in London and were obviously two of a kind.

The ammunition for these long chambered guns was different to that used in the later Mk I and Mk II guns in that the shell casing and projectile were fixed together in the same manner as six pdr Q.F. rounds. The combined length of the shell casing and projectile was 40 mm longer than the Mk I and Mk II combined cartridge and projectile. As a result of these differences, the ammunition was not interchangeable between the long chambered prototype guns and the later Mk I and II guns.

⁷ Diary of Engineer William George Robertson, courtesy of the Seapower Centre, Canberra, A.C.T.

⁸ *Log Book of HMVS Cerberus*, National Archives of Australia.

⁹ *The Leader*, 28 July 1900.

¹⁰ Victorian Naval Contingent Bill, *Victorian Hansard*, 10 July 1900.

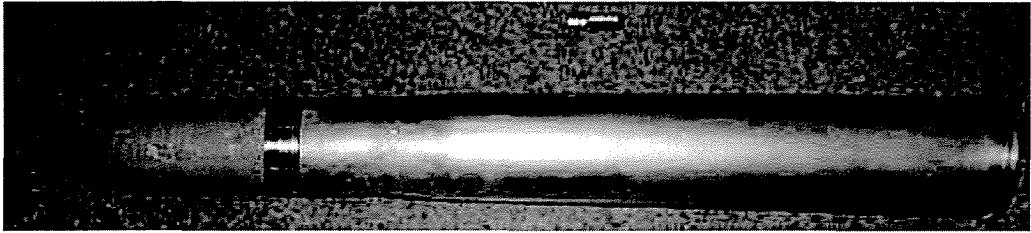

14 pounder projectile (in undercoat grey) and shell casing (800 mm) with AA battery for scale.¹¹

As was the case with the early Mk I projectiles, black powder was used as the propelling charge. The *Victorian Naval Forces Manual* for 1890 stated that 6½ pounds of 45 hexagonal indented black powder was used whereas Andrew Currer’s copy of the manual had a handwritten note which gave the charge as 7 lb 2 oz P.B. (pebble).¹² From the *Diary of W.G. Robertson* and *Cerberus Log Book* entries we know that Shrapnel, Case & Iron Common projectiles were available for use.

According to the 1908 *Treatise on Ammunition*, the only other British ships to mount 14 pdr Q.F. guns were HMS *Swiftsure* (Mk I version) and HMS *Triumph* (Mk II). Both ships were completed in 1904 and carried fourteen 14 pdr guns. As mentioned above, these guns differed from those on *Cerberus*.¹³

Velocities and Penetration 14

Gun & Weight	Charge	Projectile	Length of Gun	Extreme Range	Muzzle Velocity	Velocity at 1000 yards	System of Obturation	Penetration at the muzzle of unbacked Wrought Iron.
14 pdr Q.F. 18 cwt	6½ lbs. 45 Hex Indented	14 lbs	11 feet 6 inches	8000 yards	2100 F.S.	1619 F.S.	Cartridge case & breech block.	7 inches

-oOo-

11 The purchase of the above round was sponsored by the *Antique Arms Collectors Society of Australia*, the *Port Melbourne Historical Society*, Marie Epstein and John Short.

12 Amendments to *Manual for Victorian Naval Forces* - 1890 Courtesy Australian War Memorial. Andrew Currer was a Signaller in the Victorian Navy.

13 *Treatise on Ammunition* 1908. (Amendments to *Manual for Victorian Naval Forces* - 1890, courtesy of Melbourne University.

14 *Manual for Victorian Naval Forces*, 1890.

THE AUSTRALIAN WHITE FLAG INCIDENT

Max Chamberlain¹

After Mafeking was relieved the Bushmen crossed the border and had the distinction of capturing the first town to fall in the Transvaal, Zeerust, on 26 May 1900, as Roberts' main army was still crossing the Vaal. They established posts at Ottoshoop and Elands River on the road to Rustenburg, and gathered rifles from the relatively docile Boers. Nearly all the houses in the Rustenburg district flew a white flag. A traction engine conveyed stores to Zeerust to be forwarded to Rustenburg. By July, with the need for troops to take part in Roberts' eastern advance, the garrisons in the west were being evacuated, and the Boers became more aggressive. On 4 July, a message was received that a small garrison at Rustenburg was being threatened. Colonel Holdsworth with 300 Bushmen made a forced march to their relief, picking up more Bushmen under Colonel Airey at Elands River, and arriving on 7 July as the situation was at its most critical. They drove the enemy out of the kopjes and then rushed the town, later taking up position at Magato's Nek.

On 21 July, Colonel Baden-Powell ordered Airey to Elands River to bring back a convoy to replenish supplies. Late at night his 300 men (from New South Wales, Victoria, Queensland and Western Australia in about equal numbers) were fired on at Koster River. Next day the Boers allowed the whole force to walk into a trap. Under General Lemmer, the Boers' 400 grew to 1000 in strong positions, while the Bushmen had only grass, trees or ant beds, and no rocks or stones, to shelter them. They nevertheless managed to keep the enemy at bay for six hours, losing six killed, 22 wounded and 200 horses killed or stampeded.

One group of ten men occupied a rise which was untenable. Most were wounded and, out of humanity, a Rhodesian officer hoisted a flag of knotted handkerchiefs over their position. It was not regarded as a general surrender as the Boers continued to fire at other targets. Most of the Bushmen did not even know of the incident, but late in the afternoon, Colonel Airey, completely surrounded and influenced by the episode and the casualties, felt honour bound to surrender. This led to confusion and Major Vialls, with the Victorians and Western Australians, refused to surrender. The fire slackened but the Boers did not come to take them prisoner.

Meanwhile, Miss Bach, a young English girl who lived at her parents' store nearby, rode to Rustenburg to alert Baden-Powell. Relief forces under Colonel Lushington from Magato's Nek and Captain Fitz-Clarence from Rustenburg threatened the Boers in flank and rear, drove them off, and the whole force retired to Magato's Nek. From the evidence of the men a white flag was flying from the chimney of a house where they had fought before the fight began. The makeshift flag raised above the wounded men had not been regarded by the Boers as signifying a general surrender as they did not cease fire. There was no suggestion that the Bushmen had sought a tactical advantage, nor is there any evidence that the Boers suffered from fire from that position in the way that the British had on many occasions when the Boers displayed the white flag on their houses.

--oOo--

¹ Max Chamberlain. *Australian tales of the Boer War*, papers presented to the Anglo-Boer War Study Group of Australia since 1997.

CAPTAIN JOHN THOMAS HYNES, DSO, MM: AN AUSTRALIAN SOLDIER

Michael MacLellan Tracey¹

Tom Johnstone's referral to examples in Cornwell's *'readable series'* of soldiers rising through the ranks to battalion and alternative commands provides an interesting insight into the process of field promotion by serving members of the military forces.² While certainly not referring to Cornwell's species of *'gutter-bred private soldier'*, this research was prompted by Johnstone's article and offers an example of an Australian soldier from Queensland who rose through the ranks during the Great War. In order to establish a symbiotic relationship between this soldier and his historical era, it is necessary to briefly describe certain historical events in his civilian life and service during the Great War. To contain the historical presence, place names are as they existed at the time of the events, e.g. 'Ari Burnu' as Anzac Cove; Allied or Imperial Forces as Anzacs. The term 'Anzac' did not exist prior to the abortive landing at Gallipoli.

The importance of historical 'correctness' is essential so that myths often interpreted from social or family heritage do not distort the historic continuum. As Lowenthal aptly states:

heritage is not an inquiry into the past but a celebration of it, not an effort to know what actually happened but a profession of faith in a past tailored to present day purposes.³

John Thomas Hynes

John Thomas Hynes (1883-1928), fondly known as 'Captain Jack', was the son of Michael Hynes from Broadford, County Clare, Ireland. Hynes immigrated to Australia where he married Anne Smith from Fenniscourt, County Carlow, in St Patrick's Roman Catholic Church Gympie, Queensland in 1871.⁴ John Thomas was born in the mining township of Herberton, North Queensland on 11 March 1883, the seventh of nine children. He grew to be a quiet, retiring man to the point of shyness and was a devout Roman Catholic throughout his life.⁵

Hynes continued the family tradition of working in the mining industry and eventually this led him to the Queensland goldfield of Charters Towers around 1908. During this period he learnt the discipline of land surveying and the associations he developed were to influence his life during and following his military service. He lived with his family at Plant Street until 1911 when he followed the economic boom in copper mining firstly to the settlement of New Charleston (later renamed Forsayth) in the Etheridge district, and later to Selwyn south of Cloncurry.⁶ He was 30 years of age and unmarried when he volunteered and enlisted in the

¹ Dr Michael MacLellan Tracey BA (Hons) (ANU), PhD (ANU) holds a Doctorate in Archaeology and Palaeoanthropology from the Australian National University. His grandmother, Margaret Anne Hynes (1878-1913), was the sister of John Thomas Hynes (1883-1928). She married Richard Alexander MacLellan who also served in the 15th Battalion AIF during the Great War. *Should anyone be interested in further history of the Hynes or MacLellan families, please contact: mtracey@heritagearchaeology.com.au

² Johnstone, T., 2009. 'Military heroes - Fact and fiction,' *Sabretache*, Vol. L, No 3, September, p. 10.

³ Lowenthal, D., 1998. *The heritage crusade and the spoils of history*, Cambridge University Press, England, p.6.

⁴ Registrar of Births, Deaths and Marriages, Queensland, District of Wide Bay, Colony of Queensland: B: 09173, 1871.

⁵ Catherine C. (MacLellan) Tracey, Townsville, Queensland, *pers. comm.* 1981; Michael Hynes, Wahroonga, NSW, *pers. comm.* 2010; Michael is John T. Hynes' nephew. His father was Patrick Hynes late of Edmonton near Cairns.

⁶ *Cairns Post*, 11 January 1911 p. 4; Queensland Electoral Roll, 1913, District of Kennedy, Subdivision of Cloncurry, No. 1211.

Australian Imperial Force (AIF) at Townsville.⁷ On 26 September 1914, he was inducted into the Infantry, 2nd Expeditionary Force with the rank of Private.



John T. Hynes while working in the mining industry Charters Towers, Queensland.⁸

Formation of 15th Battalion

The 15th Battalion AIF was raised on 15 August 1914, immediately following the onset of the Great War.⁹

Colonel John Monash (1865–1931), [later General Sir] commanded the 4th Brigade that comprised the 13th Battalion of infantry from the New South Wales, the 14th from Victoria, the 15th from Queensland and Tasmania and the 16th from South Australia and Western Australia. The 15th Battalion consisted primarily of volunteers from Queensland and as part of the 4th Brigade, embarked from Western Australia bound for Egypt in December 1914.

Following enlistment in 1914, Hynes had been inducted into the Armed Forces from Enoggera Army Camp on 16 October.¹⁰ On the completion of initial training he embarked with the 15th Battalion from Melbourne on 22 December 1914 aboard the 18480 ton HMAT *Ceramic* bound for Egypt.

⁷ Queensland Electoral Roll, 1908, Division of Kennedy, Subdivision of Charters Towers, No. 4305.

⁸ John Robert Tracey Photographic Collection, H-JT001.

⁹ Chataway, T. P., 1948. *History of the 15th Battalion, Australian Imperial Forces; war 1914-1918*, revised Paul Goldenstedt (ed.), William Brooks & Co., Brisbane, Qld.

¹⁰ Australian Military Forces, Australian Imperial Force, *Attestation Paper*, 16 October 1914.



Troops boarding HMAT [SS] *Ceramic A40* in Port Melbourne, 1915.

The 4th Brigade

The 4th Brigade became part of the New Zealand and Australian Division and entered the hostilities and participated in the landings at Gallipoli in the late afternoon of 25 April 1915. Members of the 15th Battalion served with distinction in this theatre until the withdrawal in December 1915.

Following the withdrawal from Gallipoli the 15th Battalion was reorganised while in Egypt. The Battalion was divided, providing experienced soldiers for the newly-raised 47th Battalion. Hynes remained with the 15th Battalion and was promoted to Corporal on 19 October 1915. The following day, 20 October 1915, he was promoted to Sergeant.¹¹ As part of the expansion of the Australian contingent the 4th Australian Division was formed from the 4th Brigade and the newly raised 12th and 13th Brigades. From June 1916 until 1918, the battalion endured the torturous trench warfare in France with the division's first major action at Pozieres in August 1916. In April 1917, lacking the promised armoured support from the British, the brigade attacked resilient German positions suffering heavy losses at Bullecourt. The remainder of that year the 15th fought in Belgium. They helped halt the German spring offensive in 1918. The battalion participated in the fighting near Amiens on 8 August 1918, continuing operations until late September. On 11 November 1918, fighting ceased and the Germans capitulated. Members of the AIF began returning to Australia for demobilisation to return to civilian life.

By November 1918, Hynes had been commissioned as Captain. In a Christmas card sent to family members Hynes signature reads 'from Capt. Jno Hynes.'

¹¹ Correspondence to M. Tracey, Australian Army, Central Army Records Office, 10 December 1982, (ref R707/1/7).

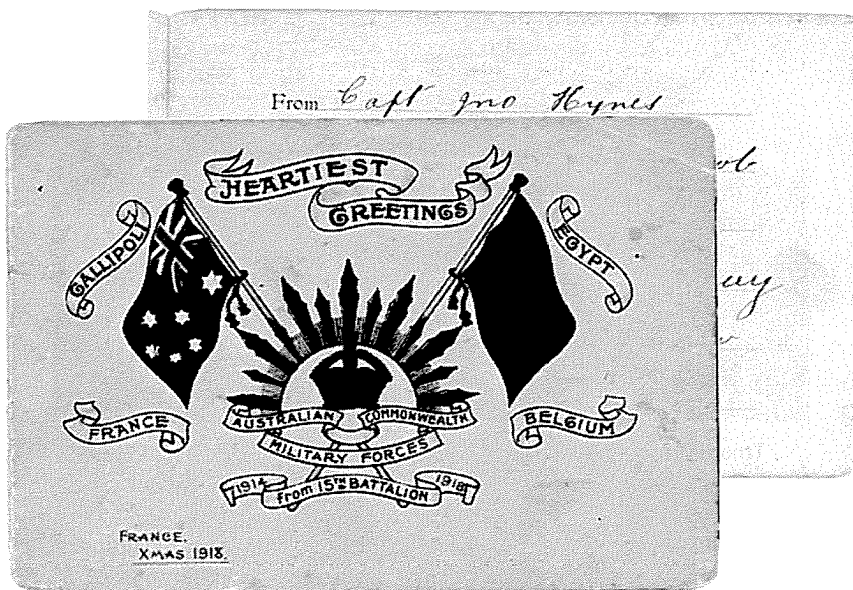

15th Battalion Christmas Postcard sent to nieces and nephews by John Thomas Hynes from France 1918.

12

The Dardanelles

Private Hynes, an inaugural member of the 15th Battalion, A Company, was appointed as stretcher bearer.¹³ He was later to be cited for his service in this rank and position:

He was the stretcher bearer and recommended for good work at Quinns Post, but did not receive an award.¹⁴

Among those who were rescued by Hynes during this action were the seriously wounded Private Thomas Henry ‘Swinger’ Ellery and Lance Corporal Alex ‘Scotty’ Wright, DCM, both of Charters Towers.¹⁵ Wright was awarded the Distinguished Conduct Medal for ‘repeated instances of gallantry when acting as a scout and guide to his unit’ on the night of 2 May 1915 during operations near Kaba Tepe.¹⁶

The Australians and New Zealanders were to assault, occupy and consolidate Quinn’s Post following the initial landing at Ari Burnu on 25 April 1915. This was part of their attempt to take Baby 700, an escarpment of approximately 590 feet (180 metres) on the Sari Bair Range. It was a principal objective of the AIF during the initial dawn landing. Within a few hours the area was occupied by elements of the 11th and 12th Battalions. Turkish soldiers had been defending the beach and were withdrawing up Sari Bair Range. British maps provided to the troops, that included the objective Baby 700, failed to illustrate the strategic importance or to reveal the

¹² This artefact of the 15th Battalion is held in the Tracey/MacLellan Family Collection. It reads: ‘Heartiest Greetings, Gallipoli, Egypt, France, Belgium, Australian Commonwealth Military Forces 1914 – 1918 15th Battalion, France Xmas 1918.’ Hynes’ salutation reads: ‘From Capt. Jno Hynes to Kathleen, Jack, Bob, Mary, Teresa, wishing you a merry xmas & happy new year’. The persons mentioned on the card were Hynes’ nieces and nephews of the MacLellan family.

¹³ Correspondence to Anne Hines [sic] from Captain J. M. Lean, Officer in Command Base Records, Victoria Barracks, Melbourne, 11 October 1915.

¹⁴ Army Form W.3121, 4 Australian Brigades, 4th Division, 1st Anzac Corps, 14 September 1916.

¹⁵ *The Brisbane Courier*, 14 December 1915, p.8; Wright returned to Charters Towers in December 1915 welcomed home by his fellow miners of the Brilliant Deeps Mine.

¹⁶ *London Gazette* No. 6545, 3 July 1915.

nature of the undulating terrain along the escarpment. As a result the troops were caught in treacherous ravines, steep gullies and unmapped open ridges with the Turks on the high ground firing down on them. Many Australians and New Zealanders were killed or wounded. The Turks held the heights and by dusk had forced the Allied Forces to retreat to the lower spurs of the escarpment.

The Turks forced the Australians and New Zealanders, despite assistance from the Auckland Infantry Battalion, to retreat to form a line of posts clinging to the cliff-edges along the Second Ridge. By dusk the near exhausted troops had been driven off the hill. The Australians eventually took Quinn's Post and it became a most advanced and dangerous position due to incessant Turkish bombardment.¹⁷ Barely 50 feet (15 metres) separated the Commonwealth and Turkish troops, and accordingly, many of the bloodiest contacts at Gallipoli occurred at this site.

The post was eventually named after Major Hugh Quinn who was also from Charters Towers. Quinn was killed on 29 May 1915, when leading a foray against the Turks trying to retake the hill.¹⁸ The Turks failed in an attack to repel the Anzacs back to the beach on 27 April 1915 and Monash ordered a second attack on Baby 700 on the night of 2 May. The attack was poorly prepared and coordinated with costly results. Turkish Forces again repelled the assault and the Anzacs suffered heavily for no gain.

On 9 August 1915, Hynes was wounded being shot through the buttocks. Owing to the seriousness of his wounds he was evacuated aboard the *Aquitania* on 11 August to 3rd London General Hospital in England for medical treatment and recuperation.¹⁹ He rejoined his unit on 19 October 1915, on the island of Lemnos where the 15th Battalion had been resting following severe losses during the fighting for Hill 971 and Hill 60 in August that year.

By December 1915, winter was prevailing and the first troops were withdrawn from Ari Burnu and Suvla Bay.²⁰ The evacuation was the most successful operation of the campaign and was executed with minimal casualties.²¹ On 27 October 1916, it was announced that '154 Cpl. J. T. Hynes, Inf.,' had been awarded the Military Medal for action at Gallipoli.²² An extract from 15th Battalion records states:

The Military Medal was awarded for bravery in battle on land to personnel below a commissioned rank serving in the British Army, Commonwealth countries and other services.

The Military Medal established on 25 March 1916 for non-commissioned ranks was the equivalent to the Military Cross as awarded to commissioned officers and Warrant Officers. Since 1993, the Military Cross has been awarded to all ranks.

A Fellow Officer

Lieutenant George Urquhart was also from Charters Towers. He was a sharebroker, a Member of the Charters Towers Stock Exchange and Secretary of the Civic Club Charters Towers in civilian life. Similar to younger boys raising their age in order to enlist, Urquhart misled his enlistment officer stating he was 44 years of age, born in Maryborough, Scotland on

¹⁷ Stanley, P., 2005. *Quinn's Post: Anzac, Gallipoli*, Littlehampton Book Services Ltd, England; *Sydney Morning Herald*, 28 July 1915, 'Men of the Dardanelles – Major Hugh Quinn of Quinn's Post' p. 14.

¹⁸ *The Age*, 4 September 1915.

¹⁹ War Gratuity Schedule, Hynes John Thomas, Lieut. 154, 'a' 15th Bt, entry 1/15/MEFO 38/6.

²⁰ *Commonwealth of Australia Gazette*, Official report on the evacuation of Gallipoli, No. 3, 10 January 1916, pp. 35-38.

²¹ *Commonwealth of Australia Gazette*, Official report on the evacuation of Gallipoli, C., No. 10, 21 January 1916, pp. 147-148; *Commonwealth of Australia Gazette*, Official report on the evacuation of Gallipoli, No. 3, 10 January 1916, pp. 35-38; *London Gazette*, 11 July 1919, Position 66, p. 883.

²² Base Records Office A.I.F., No. 60892, 25 April, 1917; *Commonwealth of Australia Gazette*, No. 62, 19 April 1917.

27 February 1871. In fact he was 50 years and six months old, born on 3 February 1865.²³ The 'cut off' age for enlistment was, at that time, 50 years of age.

Urquhart had considerable previous military experience. Following his public school education he served for six years in the 4th Volunteer Brigade Seaforth Highlanders, attaining the rank of Acting Provost Sergeant.²⁴ Urquhart also used this experience in military service to successfully apply for a commission on 4 November 1915. He survived the war although was relieved of service in early 1919, when during an operation for appendicitis, the doctors questioned his age. Urquhart was repatriated to Australia and returned to Charters Towers where he joined the accountancy firm of A. McCallum and Company in Bow Street.²⁵ He died on 19 August 1949.²⁶

Gold was the primary economic interest of the Charters Towers Stock Exchange. Hynes was a miner and worked as a surveyor and would certainly have met Urquhart in the small township during his mining days. Their places of residence in Charter Towers were in close proximity to each other. Urquhart did not participate in the Gallipoli campaign but joined the 15th Battalion in France. Also unlike Hynes, Urquhart's commission was granted based upon prior military service whereas Hynes rose through the rank by appointment without application based upon past service. Both Hynes and Urquhart were recovering from wounds and fellow officers of 15th Battalion. Urquhart escorted Hynes when he was awarded the Military Medal. Lieutenant Urquhart wrote of Hynes in the *Northern Miner* in 1916:

Sgt Hynes in his present capacity is a very valuable member of the battalion and sets a high standard in the way he looks after the wants of the members of his company. He has not yet received any recognition for his meritorious service and gallant conduct.

Urquhart later states in reference to the award made on 27 October 1916:

Today he [Hynes] was decorated by General Birdwood with the Military Medal for good service at Suvla in Gallipoli in August 1915. I happened to be the officer detailed to escorted Hynes and two other men before General Birdwood. And had the privilege of listening to the General's congratulations on the men's conduct. Hynes is at present Sergt-Major of A Company, and has every confidence and respect of not only his own company officers, but of every officer in the battalion. There should further promotion for Hynes at no distant date ...

Hynes was promoted to Company Quarter-Master Sergeant on 30 October 1916.²⁷

For '... consistent good work in France in 1916' he was promoted to Company Sergeant Major, (CSM) and awarded the Cross of Karageorge, 2nd Class with Swords or, also now known as, the Serbian Silver Star.²⁸ The Cross of Karageorge is a Serbian Royal Order and is a very rare award for an Australian soldier. The decoration was introduced in 1915 for acts of conspicuous bravery in the field by Non-Commissioned Officers and soldiers.²⁹

²³ George Urquhart was the son of the Maryborough [Scotland] sawmiller, Donald Urquhart.

²⁴ Australian Military Forces, Australian Imperial Force, Attestation Paper, (no 4727), 30 June 1915.

²⁵ Correspondence to M. Tracey 7 March 2010, from Ron Miller; Subject (Aus-Qld) George Urquhart – Charters Towers).

²⁶ Registrar of Births, Deaths and Marriages, Queensland, Register No.1949/3339.

²⁷ 154. J.T. Hynes, *Statement of Service*.

²⁸ *Commonwealth of Australia Gazette*, 25 July 1917, p. 1543; *London Gazette*, p. 1609, 25 July 1917; Correspondence to M. Tracey 10 December 1982, Australian Army, Central Army Records Office, Ref: R707/1/7, p. 2;

²⁹ Base Records Office A. I. F., 6 August 1917, No. 798.



CSM John Thomas Hynes³⁰

Hynes was noted for gallant action during 1916 and was mentioned in dispatches:

He was the stretcher bearer and recommended for good work at Quinns Post, but did not receive an award. ... He was again strongly recommended for gallant work on morning 8 August [1916], during an attack in Abdel Rahman' Bair when his battalion suffered abnormal casualties. He did valuable work during the attack and afterwards in the retirement he was noted for his courage & entire disregard for his own safety when bringing in wounded under fire and finally carried [in] on his back his Coy. Sgt. Major who was mortally wounded.³¹

Hynes received his commission to the rank of Captain on 18 September 1918, and was recommended for the Military Cross.³² However, this recommendation was reconsidered and the award upgraded to the Distinguished Service Order (DSO).³³ The DSO was instituted on 6 September 1886, by Queen Victoria in a Royal Warrant published in the *London Gazette* on 9 November. The award is a military decoration of the United Kingdom and Commonwealth countries to recognise meritorious or distinguished service by officers during wartime and actual combat.³⁴

³⁰ Australian Army, Central Army records Office, 10 December 1982, (ref R707/1/7), p. 1; John Robert Tracey Photographic Collection, H-JT008.

³¹ Commonwealth of Australia Gazette, 25 July 1915, No. 11.

³² *Supplement to the London Gazette*, 10 December 1919, p. 15293; Supplement to the London Gazette, 2 April 1919, p. 4318; Proclamation by King George V, 2 April 1919, AWM PR00889.

³³ Army Form 3121; Base Records Office A.I.F., 1 April 1920; *Second Supplement, Commonwealth of Australia Gazette*, 25 March 1920, No. 31680.

³⁴ *London Gazette*: No. 25641, pp. 5385–5386, 9 November 1886.



Captain Hynes medals including the Distinguished Service Order, the Military Medal and the Cross of Karageorge with Swords.³⁵

During World War I the DSO was afforded the rank of Major or higher. However, the honour was awarded to especially valorous junior officers. The awarding of the DSO to 'Junior' staff officers caused concern and resentment among officers in combat. From the 1 January 1917 field commanders could only recommend the DSO for those serving under fire and it was only awarded to soldiers 'Mentioned in Despatches'. However, a number of junior officers were awarded the DSO. This award was an acknowledgement that the officer had narrowly missed out being awarded the Victoria Cross.

In March and April 1918, the battalion helped stop the German spring offensive. The battalion participated in the great allied offensive of 1918, fighting near Amiens on 8 August 1918. This advance by British and Commonwealth troops was considered the greatest success in a single day on the Western Front. General Henry Rawlinson, a Commander in the British Army, commented that the Australian assault on Mont St Quentin as the 'the greatest military achievement' of WWI.

General Sir John Monash commanded the assault on Mont St Quentin from August 31 to 5 September 1918 and this action significantly added to shortening the duration the war.

Hynes participated in this battle and was mentioned in dispatches as follows:

During the operations near Jeancourt, north west of St. Quentin, on 18th September, 1918, he led his company with great skill and courage in the attack, gaining his objective at little cost. He captured about 150 prisoners, two field guns and numerous machine guns. He did fine work.³⁶

³⁵ John Robert Tracey Photographic Collection, H-JT004.



150 prisoners captured at Jeancourt on 18 September 1918.³⁷

The 15th Battalion continued operations until late September, and on 11 November 1918, the war to end all wars, ceased and the guns fell silent. Later in November, members of the AIF began to return home to Australia for demobilisation and discharge.

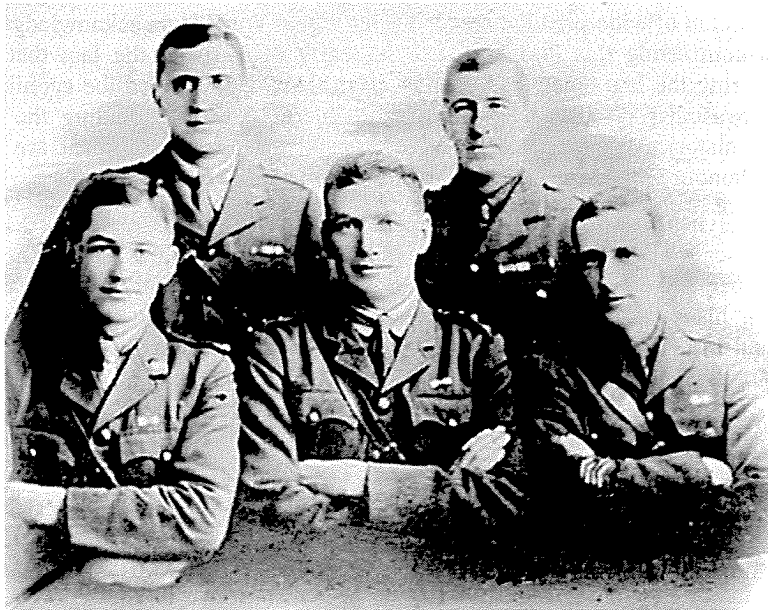

The group portrait of five AIF Officers was taken at the Federal Studio in Townville in 1919 to celebrate the return from action during the war. In the back row, left to right are Captain Robert Glasgow DSO MC, 15th Battalion, Captain John Thomas Hynes DSO MM, 15th Battalion. In the front row are Major Charles Francis Duchatel MC, 5th Australian Light Horse Regiment, Captain Sydney Hubert Carroll MC, 4th Machine Gun Battalion and Captain William Montague Cory MC and Bar, who served with the 4th Machine Gun Battalion. ³⁸ ³⁹

³⁶ *Commonwealth Gazette*, No. 30, 25 March 1920.

³⁷ AWM, ID Number E03264. Unknown Official Australian Photographer.

³⁸ Federal Studios, Townville, 1919.

³⁹ Negative Number: P02311.001, AWM Database - Donor M. Fitzgerald.

Repatriation

Captain Hynes was repatriated to Australia and returned to Cairns, Queensland. 40 He retired from the Defence Force, returned to his occupation as a miner and in 1919, was working on the copper field at Selwyn south of Cloncurry.41 During the post-war era he led a retiring life and little is known of his activities. He remained unmarried and died in the Randwick Military Hospital, now known as the Prince of Wales Hospital, Sydney in 1928.42

Michael Hynes, the nephew of John Thomas Hynes, stated that Hynes had visited South Africa. This may have been sometime during 1921-1922 or 1927.43 In these years, Hynes is not noted on the Australian Electoral Roll. While in South Africa it is believed he worked as a surveyor. It is arguable that Hynes returned to Australia from South Africa with failing health from the onset of tuberculosis. He had received wounds to his back and chest and was said to have been gassed during the Somme offensive. The after-effects of gassing and chest wounds would have exacerbated tuberculosis.44 When Hynes was wounded in the buttocks in 1915, he was evacuated to England for medical treatment. It is unfortunate that while recuperating from wounds in London he contracted syphilis during a liaison with a London prostitute.45 The presence in London of widespread venereal disease during World War I is an acknowledged fact.46 It is possible that contracting this disease led to his early demise and the fact that he remained unmarried. During the late nineteenth century clinical studies revealed the syphilitic origins of chronic cardiovascular disorders and damage to internal organs including the lungs.47 The details of the historical occurrence of Hynes' sexually transmitted ailment are not meant to demean or dishonour him or any service person.

During 1928, Hynes' health continued to decline and with his sister-in-law Mary Margaret Lyons-Hynes, her son Michael and family friend Sadie Moylen by his bedside, he passed away on 16 September 1928. He was 45 years of age. Having survived the rigours and horrors of World War I, his official cause of death was given as pulmonary tuberculosis, toxæmia, exhaustion and heart failure. Hynes was buried alongside his father, Michael Rochford Hynes (1844-1899) in the Rookwood Cemetery, Sydney, NSW. 48

Captain John Thomas Hynes DSO, MM a simple Australian Soldier who rose through the ranks in a tumultuous war now lies in peace. *'Honor [sic] to Whom Honor is Due'*.49

40 Electoral Roll, Subdivision of Cairns, 1921 /22, No. 2730; Electoral Roll, Subdivision of Herbert, Cairns, 1925, No. 3265; Electoral Roll, Subdivision of Herbert, Cairns, 1926, No.3697; Electoral Roll, Subdivision of Herbert, Cairns, 1928, No.2709.

41 Electoral Roll, Subdivision of Boulia, 1919, No. 469.

42 Lawrence, J., 2001. *Pictorial History of Randwick*, Kingsclear Books, Alexandria, pp. 11-17; Michael Lyons Hynes, Wairoonga, NSW, *pers. comm.*, 2010.

43 Michael Hynes *pers. comm.*, Wairoonga, NSW.

44 Registrar Births, Death and Marriages, NSW: Death Certificate No 1928/012726, 13 Feb 2010; Form 1. 1238, Syphilis case-sheet, 4315, Lt Hynes, 15th Btn, 28-12-17.

45 *Army War Gratuity Schedule*, Hynes John Thomas, Lieut. 154, "a" 15th Bt, entry 21/12/17.

46 Siena, K, P., 2001. 'The 'foul disease' and privacy: the effects of venereal disease and patient demand on the medical marketplace in early modern London', *Bulletin of the History of Medicine*, No 75 (2), pp.199-224.

47 Neefs, H., 2004. 'The introduction of diagnostic and treatment innovations for syphilis in postwar VD policy', *Dynamis, Medical and Science History*, No 24, pp. 93-118; Brandt, A, M., 1985. *No magic bullet: a social history of venereal disease in the United States since 1880*, New York, Oxford University Press, 1985, p. 11.

48 Registrar of Births, Death and Marriages, NSW: Death Certificate No 1928/012726, 13 Feb 2010; Rookwood Report, 1 March 2010, Michael Rochford Hynes, Register No. 6391, Sec.M1-3lot10 X 15.

49 *The Cairns Post*, 20 October 1917, p. 4.

A Mark of Respect

In 1987, the author was commissioned by the Monnaie de Paris, France, to design and sculpt a plaster for medallion to commemorate the service by Australian soldiers in France. The Director of the Australian Bicentennial Authority, James Kirk, made the following statement:

I was delighted to learn of your success ... for the design and sculpting of the medallion to be struck by the French Mint to commemorate two hundred years of Franco-Australian friendship. International recognition of your work not only enhances the reputation of our artists overseas it also helps to create pride in ourselves as Australians. Pride in our achievements is the spirit of our Bicentenary.⁵⁰

Media Release from the Australian Bicentennial Authority, 7 September 1987, states:

More than 400 French and Australian artists were invited to enter their designs for the medallion ... The French have long been considered the leaders in medallion design so this award offers considerable prestige to the Australian artist.⁵¹



The Franco-Australian friendship Medallion struck in 1988.

The medallion was struck by the French Mint in limited editions of silver and bronze. Both silver and bronze medallions are on permanent display in the **Amiens Museum**. The design featured a typical Australian and French soldier saluting each other surrounded by a war cemetery. While the Australian soldier depicted on the medallion represents all Australian service men and women in both world wars, the sculpting of the Australian soldier was based upon the service of Captain John Thomas Hynes.

⁵⁰ Correspondence from to M. Tracey from *Australian Bicentennial Authority* to, ref JFK:RM, 31 August 1987.

⁵¹ Correspondence from *L' Ambassadeur Roger Duzer, Ambassade de France en Australie*, 21 April 1988; *Comité Français Pour Le Bicentenaire De l'Australie*, Press Release, Paris, France, 19 June 1987; The Australian Bicentennial Authority, Media Release, 7 September 1987.

Bibliography

- Bean, C., 1924. *The Story of Anzac; Official history of Australia in the War of 1914-1918*, Vol. 2, Angus and Robertson, Sydney.
- Billett, R. S., 2009. *Mont St Quentin: A soldier's battle*, Rosenberg Publishing, Australia.
- Black, J. (ed.) 2005. *The seventy great battles of all time*, Thames and Hudson, London, England.
- Brandt, A. M., 1985. *No magic bullet: a social history of venereal disease in the United States since 1880*, New York, Oxford University Press.
- Brighton, T., 2008. *Masters of Battle; Monty, Patton and Rommel at war*, Penguin Books, London.
- Broadbent, H., 2009. 'Gallipoli's first day; Turkish documents separating myth and reality', *Warfare*, Andrew McDonald (ed.), Australian War Memorial, Canberra, ACT, pp. 44-47.
- Carlyon, L.A. 2002. *Gallipoli*, Pan Macmillan, New York, USA.
- Chataway, T. P., 1948. *History of the 15th Battalion, Australian Imperial Forces; war 1914-1918*, revised Paul Goldenstedt (ed.), William Brooks & Co., Brisbane, Qld.
- Couvalis, G., and Simpson, C., 2000. 'Anzac heritage or Anzac history: Truth or fiction?' *Alternative Law Journal*, AGIS 00/4136, Volume 25, No 4, August, pp. 165-68/184.
- Cross, R., 2008. In memoriam, remembering the Great War: In association with the Imperial War Museum, Ebury Press, London, England.
- Harris, J. P., 2008. *Douglas Haig and the first world war*, Cambridge University Press, Cambridge, UK.
- Jeffery, K., 2010. *MI6: The history of the Secret Intelligence Service 1909-1916*, Bloomsbury, England.
- Johnstone, T., 2009. 'Military heroes - fact and fiction,' *Sabretache*, Vol. L, No 3, September, The Military Historical Society of Australia, Canberra, ACT, p.10.
- King, J., 2008. *The Western Front diaries: The ANZACs 'own story battle by battle*, Simon and Schuster, Australia.
- Lawrence, J., 2001. *Pictorial History of Randwick*, Kingsclear Books, Alexandria, NSW.
- Lowenthal, D., 1998. *The heritage crusade and the spoils of history*, Cambridge University Press, England, p 6.
- McKernan, M., 2006. *The strength of a nation: Six years of Australians fighting for the nation and defending the homefront in WWII*, Allen and Unwin, Crows Nest, Australia.
- Neefs, H., 2004. 'The introduction of diagnostic and treatment innovations for syphilis in postwar VD Policy', *Dynamis, Medical and Science History*, No 24, pp. 93-118.
- Pegram, A., 2009. 'The arms of black melancholy: Australian prisoners captured on the Western Front in April 1917 were subjected to brutal German treatment', *Warfare*, Andrew McDonald (ed.), Australian War Memorial, Canberra, ACT, pp. 38-42.
- Scott, G. R., 1996. *The history of prostitution*, Random House, London.
- Stanley, P., 2005. *Quinn's Post: Anzac, Gallipoli*, Littlehampton Book Services Ltd, England.
- Waite, F., 1919. *The New Zealanders at Gallipoli*, Whitcombe and Tombs Ltd., Christchurch, New Zealand.
- Watney, J., 1977. *The Churchills: Portrait of a great family*, Gordon and Cremonesi, The Anchor Press Ltd, Essex, England.
- Wolff, L., 2003. *In Flanders fields: The 1917 campaign*, The Folio Society, London, England.

Journals

Bulletin of the History of Medicine, No 75(2).

Newspapers, Gazettes and Selected Articles

The Cairns Post, Cairns, Qld.

The Age, Melbourne, Vic.

The Advertiser, Adelaide, SA.

The London Gazette, London, UK.

The Commonwealth of Australia Gazette, Sydney, NSW.

Commonwealth Gazette, No. 30 25 March 1920.

Commonwealth Gazette, Official report on the evacuation of Gallipoli, Bean C., No. 10, 21 January 1916, pp.147-148.

Commonwealth of Australia Gazette, Official report on the evacuation of Gallipoli, No. 3, 10 January 1916, pp. 35-38.

London Gazette: no. 25641, pp. 5385-5386, 9 November 1886.

The Age, 4 September 1915.

The Advertiser (Adelaide), Tuesday, 21 September 1915, The Australian in Battle; Further fighting of Gallipoli General Hamilton's Official Dispatch; Dare-Devil Spirit of the Southerners; Splendid bravery and devotion to Duty p. 7.

The Advertiser (Adelaide), Tuesday, 4 September 1915, The gallant Australians: Magnificent tactics, p.15.

Collections

John Robert Tracey Photographic Collection.

The Australian War Memorial Database.

THE ARAB REVOLT: ITS ROLE IN WORLD WAR ONE

Neil Dearberg

The *Arab Revolt* was an uprising by the Hashemite Arabs of the Hejaz area of the Arabian Peninsula against the Ottoman Turks who had occupied the area for over 500 years. During World War 1 other tribal Arabs joined the revolt and all forces, at times, participated in the British led *Egyptian Expeditionary Force [EEF]* campaign in the Palestine region, in addition to their own battle objectives.

An old man fired his rifle on the 5 June 1916, in Mecca – an aging man with dreams of a unified Arab nation and himself as King of the Arabs. The *Arab Revolt* began. That shot was a first-up fizzer. Four months later Sir Ronald Storrs arrived on an investigative trip to the Hejaz to ascertain British support for this ‘revolt of the Arabs’.

Militarily, the revolt gave some support to the British led war-effort by locking up around 15000 Turkish troops in Medina for the duration plus consistent interdiction to the Hejaz Railway and interference to Turkish logistics. In the final stage of the Palestine campaign, the Arab Army had the honour of being first to enter Damascus.

That old man was Sheik Hussein bin Ali, a descendant of the Prophet Muhammed and the Sheik of Mecca (Islam’s holiest site). This made him the spiritual leader of Muslims in the whole of Arabia, whilst also the tribal leader of the Hashemite Arabs of the Hejaz region – a highly respected person amongst Arabs and Muslims everywhere.

For 15 years, Hussein and his family (including four sons Ali, Abdullah, Feisal and Zeid) had been the reluctant guests of Abdul-Hamid II, the Sultan of Constantinople and ruler of the Ottoman Empire that controlled Arabia at that time. From 1893, while enduring this reluctant ‘guesthood’ to satisfy the Sultan’s idea of stability in the Hejaz, Hussein educated his sons in politics, languages, warfare and social graces in preparation for their eventual return to the Hejaz.

The Ottoman Empire was an aging relic, at the twilight of its once dynamic 500 year period. By 1908, it was in its final stages of decline and the seeds of internal revolt had formed as a group of ‘Turkish nationalists’, known as the Young Turks, was forcing the Sultan to amend his corrupt and idiosyncratic ways that were leading the Empire to ruin. Nevertheless, Abdul Hamid did have the odd bright spot. For one, the Sultan had ordered the building of the Hejaz Railway from Damascus to Mecca although it was only ever completed to Medina (the second holiest site in Islam) – this being done between 1901 and 1908. Part of the reasoning for the railway was to enhance the Sultan’s prestige amongst his Muslim followers by giving them greater opportunity to be good Muslims. It would also connect to the German inspired Berlin to Baghdad railway.

The *Hajj* pilgrimage to Mecca became easier and less dangerous with three days on a train from Damascus instead of 40 days through a hostile land with a paid Bedouin escort and suppliers, itself subject to looting, murder and bribery by other Bedouin; or a voyage by ship through the Suez Canal and subject to British favours. The Bedouin tribes became quite put out by their new found lack of revenue so started shooting Ottoman tax collectors and a few soldiers for a different reward. They also found reward in periodically attacking the trains and passengers. In addition, the Arabs recognised the Hejaz Railway as a funnel for extended Turkish and German troop movement through the Hejaz, to the holy cities of Mecca and Medina and the Arabian Peninsula. This would impose even greater restrictions on Arab life and welfare.

As the temples of Greece and Rome had collapsed from earthquakes, so the Ottoman Empire was collapsing from failure of leadership. In the decades preceding World War 1 (WWI), after nearly five centuries of Ottoman expansion, the French, Italians and British had relieved the Empire of virtually all of North Africa. The Balkans and Greece had been lost and the Russians were giving them a hiding in the Caucasus. Internally, political turmoil was erupting – the Sultan had his powers restricted between 1908 and 1912 by that new band of elites, the Young Turks and the Committee for Union and Progress [CUP]. Although the Sultan was corrupt and feared, the politics of his day had allowed Muslim, Jew and Christians to participate in government, commerce and the military. Under the Young Turks however, it was the Turkish members of the CUP who rose to prominence and positions of influence, while others took much more minor roles.¹

Those Arabs now with lesser status formed ‘secret societies’ and formed the consequential revolt within Turkey and the occupied areas. These northern or Syrian Arabs, were formulating even greater discontent towards ongoing Ottoman rule and were pressuring Hussein through his son Feisal, to revolt in concert with the British; in which case they would accept him as King of the Arabs. This later became the seed of the *Damascus Protocol*. Further, Germany was pressuring the Young Turks to accept its military advice, advance a railway to Baghdad, extend their influence into Palestine and take on the Russians more effectively. The Germans exaggerated the plight of Turkey since the British Government had completed a peace and trade agreement with Russia, the archenemy of Turkey, only two decades earlier. Germans proffered themselves as ‘saviours’. The Young Turks succumbed to this Germanic ‘assistance’ that had been reinforced by the Kaiser’s visit in 1898. Add to this, other Arabs were stirring trouble in Arabia and especially the western area of the peninsula in the Hejaz and the home of Hussein and his now grownup sons.

Ironically, the Sultan now had to agree to the CUP and Young Turks’ wish to return Hussein and his family to the Hejaz to hopefully restore peace on the Arabian Peninsula; the very thing the Sultan initially thought Hussein’s presence would evaporate. How right he was. Anyway, home they went in December 1908 with Hussein appointed as Emir of Mecca, to influence all the tribes of the Arabian Peninsula and restore harmony towards the Ottomans. The groundswell for an uprising by Arabs against the Ottoman occupiers had grown. Now they sought a leader, but, creating unity amongst Arabs was like herding cats. The tribes of the Rashids of the Shammar, the Sauds of the Nejd, the Indrissi in the south of the Peninsula and the Yahyas of Yemen, each in their tribal lands of the Arabian Peninsula, were tolerant but not ardent supporters of Hussein (or each other); and then only whilst it suited them – and that was not long in Arab politics of the day.

Before the start of world hostilities in August 1914, Hussein had to contend with his mixed loyalties towards his fellow Muslims and maintaining allegiance to the Ottomans or, forge independence and his own destiny with the so-far indecisive British and French at his side. His son Abdullah, having sounded out Lord Kitchener early in 1914, gained an official rejection on the basis Britain and the Ottomans were not at war. But he was possibly also given an indirect feeling that British support could be forthcoming, provided the Arabs rose against the Ottomans in the event of a war.

After the outbreak of war, further serious discussions took place between Hussein and Sir Henry McMahon who, having replaced Kitchener when he was recalled to London to become Secretary of War was then High Commissioner in Egypt. A series of correspondence became known as the *Hussein-McMahon Letters* and gave an indication of British support for an Arab Revolt with future support for an Arab nation, of sorts. (In 1919, the Paris Peace

¹ M. Sükrü Hanioglu. *A brief history of the late Ottoman Empire*, Princeton University Press, 2008.

Conference, of the victorious allies revealed that these letters were too ambiguous and vague, so denied the rule of lands and people and the formation of Hussein's dreamed Arab nation.)

War between Britain and Germany broke out in August 1914 with Turkey joining Germany in October of that year. The Sultan in Constantinople then decreed to all Muslims:

know that our state is at war with the Governments of Russia, England and France and their allies, who are the mortal enemies of Islam. The Commander of the Faithful, the Caliph of the Muslims, summons you to the Jihad.²

Hussein was quick to notice that the Sultan now viewed Germans as non-Infidels and exempt from the Jihad. He was further put out that someone else should be telling the Sheik of Mecca and Protector of the Holy Site, to engage in a Jihad! He became really angered when it was discovered that the Sultan and Young Turks were also planning to depose him and have him replaced as Sheik of Mecca.

While this was going on, India became an issue. British political and military leaders and their staff were opposed to British interference in Muslim lands for fear of inciting the Jihad further and turning India's huge Muslim population against Britain. They were also concerned to protect the oil fields of Mesopotamia, the Royal Navy having converted to oil in 1908.³ Eventually, certain Indian Muslims agitated to promote the Jihad amongst the Arabs and did so in a series of letters, to be known as the *Silk Letters*. Fortunately, this concern did not materialise.

In parts of the British Government and military command, there was vociferous opposition to any campaign in the Hejaz, arguing that the war effort be directed against Germany on the Western Front campaigns. These 'westerners' as their policies became known were influential and ultimately decisive in British political and military strategy.

The Ottomans then began to turn the tables on the Russians who called for military help from Britain and France. In early 1915, the Royal Navy was unable to force the Dardanelles and ground forces from Britain, France and the Dominions were landed on 25 April. The Turkish military was successful and the allies in December 1915 and January 1916 evacuated in a brilliant, undetected withdrawal.

The French, Russian and British Governments were, early in the war, giving consideration and defining new boundaries for the division of the Middle East for a post-war 'sharing of the spoils'. Out of this, in 1916, came the *Sykes-Picot Agreement*. It is now arguable, but seems likely, that they told Hussein about their longer-term territorial aims and how these differed with his view of an Arab nation and his regal status as King of the Arabs.

Another factor was also at work, Zionism. In the 19th and early 20th centuries, there had been small, steady influxes of European Jews into Palestine. The Ottoman rulers and the local Arabs, of whom some were Christian, accepted the Jews. Within the Empire, Jews and Christians could vote and were eligible for military service in the Ottoman Army. However, at the outbreak of WWI, Jews were deprived of weapons and uniforms and put into labour battalions. They now became a hated group and their numbers sought a 'homeland' for existence.

After the outbreak of war, Chaim Weizmann continued to lobby the British Government and politicians for acceptance of Palestine as the Jewish 'home'. The *Balfour Declaration* came to pass in November 1917.

² Barr, James. *Setting the Desert on Fire*, Bloomsbury 2006, p.3.

³ Lawrence, T.E. *Seven Pillars of Wisdom*, Penguin Books 1935, p. 23.

However, there was an additional group of British political and military leaders who recognised the political machinations as well as the military and strategic importance of the East. For example Kitchener, before his premature death (coincidentally on the same day that Hussein fired that now famous shot), recognised the vitalness of the Red Sea and Suez Canal and its susceptibility to interference to shipping and supply from India and Australasia, plus the oil of Mesopotamia. So there became a group of 'Easterners' who saw strategic value in supporting the Arabs and a campaign in the Middle East.

It is interesting to ponder if the powers that were at that time, gave any thought to the economic significance, in addition to the military advantages, of this area where three continents joined and trade routes had passed for thousands of years. What thought to recovery of the Holy Land that had been lost 730 years earlier when Saladin captured Jerusalem? Was it recognised that who controlled the Middle East controlled Suez, the sea route of the Red Sea, the land trade routes, the British Aden Protectorates, the Christian, Jewish and Islamic holy sites, water, oil and food? What thought was given to home morale if a quick victory could be had, to compensate for the stalemate and likely death toll of the French theatre? Indeed, some did.

To improve knowledge, in early 1916, the British gathered in Cairo what was called the Arab Bureau. A group of intelligence officers was formed to gather and distribute information about the Arab world to assist the policy makers in London, Delhi and Cairo itself.⁴ This is where Lieutenant T E Lawrence (later Lt Col), who became known as Lawrence of Arabia, the 28 year old archaeologist with no military experience but a vivid imagination, has been endeared as a gifted revolutionary. The Arab Bureau also had other active officers, and whilst no others gained the reputation of Lawrence, many may well have contributed equally or perhaps more greatly, than this fabled man.

As part of the British war effort, the Arab Revolt played a part in the defeat of the Turkish Army and eventual collapse of the Ottoman Empire, allowing the formation of today's secular Republic of Turkey.

World War 1 was politically and consequently militarily, a confused sea of competing theatres and promises. Misgivings and enthusiastic but immature decisions by key British policy-makers resulted in what was termed a 'sideshow' in the east with emphasis given to France and Belgium. In 1915 and 1916 there was little real knowledge of Arabia and little understanding of its strategic importance and the consequential disasters had it been lost and how the future could have unfolded. An Arab Revolt was given support and its influence today is still poorly understood, but influential in today's world it surely is.

The old man, who declared himself Kind of the Arabs and Caliph failed to gain the support of all Arabs. In 1924, he and his son Ali lost a battle with Abdul Aziz ibn Saud. He was exiled in Cyprus and the formation of today's Saudi Arabia came into being and included the Hejaz. His son Abdullah became King of Transjordan under British mandate. The French evicted son Feisal from Syria in 1924, so the British made him first King of Iraq. His dreams shattered, his sons spread, and his influence was gone.

-oOo-

⁴ Westrate, Bruce. *The Arab Bureau, British Policy in the Middle East 1916-20*, Pennsylvania Press, 1992.

THREE SOVIET AWARDS TO MEMBERS OF THE AUSTRALIAN MILITARY FORCES FOR WORLD WAR II

Graham Wilson

A feature of both World War I (WWI) and World War II (WWII) was the exchange of military decorations between Allied nations. Meant as a gesture of solidarity and, quite possibly, a propaganda exercise, for the Forces of the British Commonwealth this allocation of foreign decorations was particularly appreciated. The reason for this, of course, is that the quota system under which the Forces of the Commonwealth nations operated precluded the visible recognition of every deserving person. It is probable, for example, that of every hundred recommendations for a Military Medal that were put forward, perhaps five would be approved. Thus the availability of additional awards outside the normal operational quota was particularly useful.

From an Australian context, in 1944, three members of the Australian Military Forces (AMF) were decorated with awards of the Soviet Union. The process commenced with the receipt of a secret cablegram from the Secretary of State for Dominion Affairs to the Governor-General of the Commonwealth of Australia (Lord Gowrie, VC) on 6 December 1943. The cablegram stated:

Soviet Government have expressed desire to confer a limited number of Soviet decorations and medals on members of His Majesty's Forces for gallantry in action with the enemy. In this connection Army Council have asked whether you and your Prime Minister would wish to nominate one officer not above the rank of Lieutenant Colonel and two other ranks of Australian Military Forces who have returned from the Middle East for three of these awards. Please telegraph what reply it is desired should be returned.

Individuals nominated should have displayed gallantry in action with enemy and not have been awarded any decoration or medal for action for which they are nominated for Soviet awards.

Names of candidates would be submitted to Soviet Government. It would of course be for them to say whether individual awards were acceptable to them and if any instance this proved to be the case, those particular candidates would naturally have to be omitted from the final list of recipients.

These proposals would be first of their kind and it is not clear whether Soviet Government would wish to have citation of services in support of them. It is suggested therefore that names and other personal particulars of any Australian candidates might be furnished by telegram and citations by Air Mail.

Interestingly, this telegram included a suggested name for the officer candidate, NX34870 Captain G.B. Connor, 2/33rd Australian Infantry Battalion. Connor had been cited for the immediate of a Military Cross by GOC 7th Australian Division on 20 November 1941. The recommendation was for gallantry in action during the Syrian Campaign of June - July 1941. The recommendation acknowledged that the submission was outside the closing date for immediate awards for the Syrian Campaign, but requested favourable consideration as a special case. The nature of the special consideration was that the then Lieutenant Connor had apparently been taken prisoner not long after the action he was cited for and had not been released until after the closing date for awards. Notwithstanding the request by GOC 7th Australian Division, 1st Australian Corps rejected the recommendation and returned it on 1 December 1941, with the notation that it should be re-submitted at a later date as a periodical award. This was duly done, but not until April 1943. Although supported by GOC New Guinea Force, under whose command 7th Australian Division now served, the recommendation was rejected once again, this time by the United Kingdom (UK) authorities who felt that the passage of time between the original action and the recommendation militated against the award. Although there is no

information on record as to why Connor's name was specifically forwarded, it seems likely that a review of officer recommendations that had been rejected was made in the UK prior to the transmission of the Soviet offer to Australia. The timing of the telegram from the Secretary of State for Dominion Affairs i.e. early December 1943, compared to the timing of the re submission of Connor's Military Cross (MC) recommendation for a periodical award, April 1943, works in quite well. This is especially so when it is taken into account that the recommendation was forwarded to London, from whence it was forwarded to Commander-in-Chief Middle East for consideration (as the action being cited occurred in C-in-C Middle East's area of authority). It was, in fact, C-in-C Middle East who ultimately rejected the re-submitted recommendation. Thus there is a high likelihood that Connor's recommendation was still fresh in the mind of some functionary in the office of the Secretary of State for Dominion Affairs and was put forward as a suggestion for the officer award of the three Soviet decorations.

On receipt of the Soviet offer, the Governor General passed the matter on to the Prime Minister (John Curtin) who in turn referred the matter to the Commander-in-Chief AMF, General Sir Thomas Blamey. Blamey apparently accepted the suggestion of Connor as the officer nominee as, on 8 January 1944, the Military Secretary sent the following signal (LHQ MS 1557) to 1st Australian Corps, repeated to 6th Australian Division:

Soviet Government desires confer limited number decorations on British forces. Australia asked to participate and C-in-C directs 6 Aust Div submit two recommendations of other ranks for his consideration. Nominees should have displayed gallantry in action in Middle East for which they received no award. Recommendations early possible.

This signal was repeated almost word for word to Headquarters New Guinea Force and 9th Australian Division on the same day as LHQ MS 1558, the only alteration being substitution of 9th Australian Division for 6th Australian Division.

1st Australian Corps responded on 17 January 1944 with 1 AUST CORPS DAMS 640, in which it advised:

With reference to LHQ MS1557 of 8 Jan 44, forwarded herewith AFs W3121 in respect of the undermentioned soldiers:-

NX 4050 Sgt MacIntyre NS 2/4 Aust Inf Bn
VX 4957 Pte Shepherd FG 2/8 Aust Inf Bn.

Head Quarters New Guinea Force responded on 20 January 1944 with MAF NG FORCE CAM/ARJ AMS 10505 in which it advised:

With reference to your MS 1558 of 8 Jan, 44, attached herewith A.F.s W.3121 recommending the following O.Rs for consideration for award by the Soviet Government:-

QX 5766 A/CPL. McHENRY, W.R. 2/15 Aust Inf Bn.
SX 7415 PTE. STEWART, A.R. 2/48 Aust Inf Bn.

After due consideration Sergeant MacIntyre of 2/4 Battalion and Private Stewart of 2/48 Battalion were chosen as the nominees and their names, along with notification of the acceptance of the suggestion that Captain Connor constitute the officer nominee, were forwarded to London. The decision had been made that the three nominees would represent the three divisions of the AIF that had fought in the Middle East. Thus Sergeant MacIntyre was representative of the 6th Division, Captain Connor representative of the 7th Division and Private Stewart representative of the 9th Division.

On 29 March 1944, the Military Secretary at Land Headquarters sent the following letter (MS1/MG 43704) to HQ 1st Australian Corps, HQ New Guinea Force and HQ First Australian Army:

HONOURS AND AWARDS. SOVIET DECORATIONS

Official confirmation has been received from the Aust. Legation Moscow of the award of Soviet Decorations to the undermentioned personnel for gallantry in the Middle East.

ORDER OF THE RED STAR.

SX7415 Private Allan Roy STEWART, 2/48 AUST INF BN.

ORDER OF THE PATRIOTIC WAR, 1st CLASS.

NX34870 Captain George Boyd CONNOR, 2/33 AUST INF BN.

NX4050 Sergeant Norman Struan MACINTYRE, 2/4 AUST INF BN.

2. *This confirms the notice that appeared in the press on 24th Mar, 44.*

On 6 April 1944, the War Office in London advised the Under Secretary of State for Dominion Affairs via WO 68/Gen/7823(MS3) that the King had been pleased to grant unrestricted permission for the acceptance and wearing of the Soviet awards made to Connor, MacIntyre and Stewart. This was followed up (same reference) by a letter on 11 August 1944 to the Military Liaison Officer at Australia House, forwarding the insignia of the awards with the request that they be forwarded to the recipients and acknowledgement of receipt obtained. The awards were promulgated in the *Commonwealth of Australia Gazette* on 23 November 1944.

The newspaper announcement of 24 March 1944, mentioned in the LHQ letter took Captain Connor by surprise and also mystified him. In a short newspaper article of 29 March 1944, advising of the award and accompanied by a photograph of the officer, it was stated that he said on his arrival in Sydney on 26 March that he did not know why he had received the award. This is not surprising as he would not have been aware of the two previous unsuccessful recommendations for the Military Cross made on his behalf.

Presentations of the Soviet awards were made to the three men by their divisional commanders, in Queensland in October 1944. Sergeant MacIntyre of 2/4th Battalion received his Order of the Patriotic War at Herberton on 11 October from Major General J.E.S. Stevens, DSO, ED, General Officer Commanding (GOC) 6th Division. Captain Connor of 2/33rd Battalion was presented with his Order of the Patriotic War at Kaira on 15 October by Major General E.J. Milford, DSO, GOC 7th Division. Finally, Private Stewart of 2/48th Battalion received his Order of the Red Star from Major General G.F. Wooten, CBE, DSO, GOC 9th Division at Ravenshoe on 23 October 1944. Interestingly, the awards were made in order of the seniority of the three divisions, i.e. 6th, 7th and 9th. Whether or not this was intentional is unknown.

Following the delivery of the insignia from overseas and their presentation to the three recipients, a short press article on Sergeant MacIntyre, accompanied by a photograph, appeared on 26 October 1944. The piece advised that:

SGT NORMAN MACINTYRE, AIF, of Parramatta, NSW (with) the Order of the Patriotic War (First Class) a high Russian decoration, awarded by the Soviet Government. The decoration carries a money grant of 20 roubles (about £1) a month for five years, free first-class travel once a year on Soviet ships and trains, and at all times on Soviet trams. If ever resident in Russia, Sgt, MacIntyre will be allowed tax-free income up to 6,000 roubles (about £300), discounts of 10% to 50% on rents, and, in the event of incapacitation, he may claim pensions. The citation stated that he frequently carried intelligence information under heavy fire, and that during the Crete evacuations he was instrumental in saving a complete company from capture.

In the second half of this article, the awards themselves will be examined.

Order of the Patriotic War

The Order of the Patriotic War was established on 20 May 1942, for award to members of the Soviet Armed Forces, security troops and to partisans for heroic deeds during the 'Great Patriotic War'. The Order was awarded in two classes, with the level of award depending on the merit of the deed being rewarded. The Order of the Patriotic War was the first Soviet decoration or medal established during WWII and was the first Soviet order to be divided into senior and junior classes. The statutes for the Order defined precisely which deeds were awarded with the Order, for example, shooting down three aircraft as a fighter pilot, or destroying two heavy or three medium or four light tanks, or capturing a warship, all qualified for the 1st Class of the Order. The Order was also available for award to Allied forces.



Order of the Patriotic War (1st Class)

During WWII 324,093 1st Class and 951,652 2nd Class awards of the Order were made. A number of awards were made post war, bringing the total of awards of both classes made up until 1985 to 1,350,000. In 1985, to mark the 40th anniversary of the end of the Great Patriotic War, it was decided that all surviving veterans of the war would be awarded either the 1st or 2nd Class of the Order. Approximately 2,054,000 1st Class awards and 5,408,000 2nd Class awards were made.

The Order consists of a red enamel five pointed star, made of silver, with straight rays in the background and crossed sabre and rifle. The rays in the background were gold for 1st Class and silver for 2nd Class. The central disc has a gold hammer and sickle on a red enamel background, surrounded by a white enamel ring upon which are the words **ОТЕЧЕСТВЕННАЯ ВОЙНА**

(Patriotic War).

Originally the Order was attached to a plain red ribbon (see below), similar to the Gold Star of the Hero of the Soviet Union, but from June 1943, the Order was to be worn on the right chest without ribbon in the same manner as the Order of the Red Star. For undress wear a ribbon bar, dark red with a bright red central stripe for the 1st Class, or dark red with bright red edge stripes for the 2nd Class, may be worn. The reverse of the original ribbon mounted insignia was plain except for the serial number, which was either impressed or engraved at either the six o'clock or eight o'clock position. The 1943 version featured a large screw fastener the same as the Order of the Red Star and the mint mark was impressed (usually) or engraved at the 12 o'clock position above the fastener. Although Soviet practice decreed that the badge of the Order of the Patriotic War was to be worn on the right breast above the pocket, either this was unknown to the Australian authorities or it was known but was too revolutionary for the conservative Australian authorities and they chose to ignore it. A photo of Captain Connor taken at the time of his investiture (AWM 081505) shows him wearing the badge pinned to the left hand pocket of his service dress jacket, below the pocket flap. Presumably Sergeant McIntyre wore his badge in the same manner.



Order of the Patriotic War 1st Class – Pre-1943 Version

Order of the Red Star

The Order of the Red Star was established on 6 April 1930 by order of the Presidium of the Central Executive Committee of the USSR. Statutes for award of the Order were instituted on 5 May 1930 with the first Order awarded on 13 May 1930 to Civil war hero, V.K. Blukher. Originally the Order was awarded to high ranking officers and officials. The requirements for award of the Order are as follows:

The Order of the Red Star is awarded for outstanding achievements in the defense of the USSR and for actions in maintaining state security in times of peace.

It was later awarded as a decoration to recognize length of service but this was discontinued on 14 September 1957 with establishment of the Medal for Irreproachable Service. The statutes for the Order state that it may also be bestowed upon a unit, ship or organisation. It may be awarded to foreigners. Worn on the left breast until 19 June 1943, at this date it was ordered to be worn on the right breast. For undress wear a red ribbon with a 5mm grey stripe in the centre can be worn in lieu of the star. When worn with other Orders it is worn after the Order of the Patriotic War, 2nd Class.

The design of the Order of the Red Star is a five pointed star in silver, filled with red enamel, 45mm in diameter. In the centre of the star is a silver disc with a figure of a Soviet soldier of the 1930's era holding a rifle. Surrounding the soldier is the inscription in Cyrillic text, **РАБОТНИКИ ВСЕХ СТРАН, СОЕДИНЯЮТ!** ('Workers of all countries, unite!'). Below the soldier are the Cyrillic letters **СССР** ('USSR') and the crossed hammer and sickle of the Soviet state in silver. The slightly concave flat reverse of the star is fitted with a large screw and nut fixture to allow the star to be affixed to the shirt or uniform jacket. The mark of the mint which manufactured the star appears above the screw and the individual number of the star is impressed or engraved below the screw.



Order of the Red Star (Obverse)

There were three distinct types of Star manufactured, covering three periods. The first type was issued between 1930 and 1936 (approximately). The second type was issued between 1936/37 to 1940/41 (approximately). The third type was issued from 1941 onwards. Based on known serial numbers, over 2,800,000 Stars were awarded during WWII.

As with all other Soviet awards, award of the Order of the Red Star was accompanied by an elaborate award document with an attractive gold embossed red leather cover. The book contained sections for the recipient's personal details, details of specific awards granted (including the name of the award, date of issue and the title and seal of the awarding authority), and details of the privileges attached to the awards.

Prior to concluding, it is worth digressing to examine a bizarre little controversy that existed for some years after WWII, connected with Sergeant Norm McIntyre, recipient of the Order of the Patriotic War. At the time of his award, McIntyre sat for a portrait painting executed by an artist named Geoff Mainwaring on commission from the Australian War Memorial (AWM). The painting (AWM ART22147) is still held by the AWM. After the war, for some reason McIntyre took it into his head that since the painting was of him then the painting must belong to him and he wrote to the Chief of the General Staff requesting the painting. Totally mystified, CGS wrote back advising that he had no idea what McIntyre was talking about. This resulted in further correspondence which led McIntyre to the AWM, which, after detailed correspondence with Geoff Mainwaring, wrote back and advised McIntyre that the painting belonged to the Memorial and that no, the Memorial was not about to give it up.

McIntyre refused to take no for an answer and carried out a letter writing campaign until his death in the 1960s in an effort to obtain 'his' painting. If the AWM heaved a sigh of relief at McIntyre's death in the 1960s, they acted too soon as no sooner had former Sergeant McIntyre passed away than his daughter took up the torch and continued with the campaign into the early 1980s!

An amusing enough little story, the whole thing still leaves a somewhat sour taste in the mouth as, even if Norm McIntyre had been honestly mistaken at the outset, his refusal to accept the facts and drop his campaign for all those years detracts very much from an interesting story.

Captain Connor, Sergeant McIntyre and Private Stewart of the AIF are all long dead and the Soviet Union has been consigned to the rubbish bin of history. For all that, it is fascinating that three members of the Australian Army were decorated by the Soviet Union during WWII.

Sources and Bibliography

Australian War Memorial File AWM119 248/20 'Award of Soviet Decorations'.

Bulow, Kerry, 2000 *Foreign Awards to Australia from World War One to the Korean War*, published by the author, Hampton Park, Victoria.

Clarke, John D., 2001 *Gallantry Decorations and Medals of the World*, Pen & Sword Books Limited, Barnsley, South Yorkshire, UK.

Durov, V.A., 1990 *Russian and Soviet Military Awards*, Order of Lenin State History Museum, Moscow, USSR.

Herfurth, Dietrich, 1987 *Militärische Auszeichnungen der UdSSR*, Militärverlag der Deutschen Demokratischen Republik, Berlin, DDR.

RAAF CHAPLAINS IN THE MIDDLE EAST, ITALY AND FRANCE 1943-45: A STUDY IN ECUMENISM

Tom Johnstone

In 1940, following the fall of France to a German *blitzkrieg* offensive, a Melbourne priest, Father (Fr) John P McNamara, already a part time Army chaplain, volunteered for active service with the Royal Australian Air Force and was accepted. In 1943, after service on air bases in Australia, he accompanied a large draft of approximately 1000 young airmen to the United Kingdom (UK); travelling via the United States and Canada to England. After a visit to his ancestral home in Ireland, Fr McNamara was posted to the Middle East. In Egypt he joined two other chaplains, Anglican chaplain Reverent (Rev) Bob Davies and Presbyterian Rev Fred McKay. Together, the three formed a Royal Australian Air Force (RAAF) chaplaincy team responsible for Australian airmen on every Royal Air Force (RAF) station in an area stretching from Basra in Iraq, west across North Africa to Olyda on the Algerian/Moroccan border, a distance of approximately 5300 kilometres – as an African falcon soars. For his travels each chaplain had a three quarter ton truck, together with driver, their service kits, religious vestments and other necessities for religious services. Thus, sparsely equipped the chaplains could operate either together or independently and going in different directions so as to cover diverse areas simultaneously. They usually opted for the latter.

During the following two years of war the three chaplains repeatedly toured their vast area of responsibility, visiting every airfield on which RAAF personnel were based; whether serving with RAAF squadrons or detached to the RAF. Their duties were not confined to spiritual needs. Mail, welfare, pay and allowances together with news from Australia were highly important especially to those few Australian airmen who might be stationed on an isolated RAF station. Sometimes the chaplains took with them a pay Sergeant to give expert advice and complete the necessary paperwork. With such a vast area to cover, which would shortly be enlarged, the three chaplains were almost constantly on the road. Within months, usually accompanied only by a driver, all three chaplains' had visited every RAF station in Middle East Air Command that had Australian airmen on its strength. Almaza and Abu Sueir, near Cairo, were easy. Not so, were distant places such as Shaiba and Habbaniya in Iraq; Ein Shemer and Lydda in Palestine, and the many airfields on the North African littoral from El Adem near Tobruk to Olyda. It was an area that would shortly include Italy and France. Essentially it meant the chaplains adopting a nomadic lifestyle. But the personal rewards for them were great. For the thousands of young airmen, whatever their religious denomination, or none, it meant that they were brought into contact, however vicariously, with the homeland and a means to a solution to their many administrative and morale problems, as well as bringing spiritual comfort. This latter was especially important to aircrew who daily confronted death at very close range.

It helped Fr McNamara that he was a good all round cricketer, and was therefore doubly welcomed by the squadrons he visited. Although travelling independently, and meeting rarely, all three chaplains became firm friends, a friendship that was destined to continue long after the war. Each of the chaplains admired the work of the others and presented to the airmen of all denominations a united Christian front. It was an early example of ecumenism that was not lost on the rank and file of the RAAF; and they, the airmen, responded enthusiastically.

In 1943, there were six RAAF flying squadrons operating in North Africa;

3 and 450 Squadrons – Kittyhawk fighter bombers on Army cooperation.

454 and 459 Squadrons – Hurricane fighters. Naval cooperation.

451 Squadron – Hurricane fighters. Reconnaissance and Convoy protection.

458 Squadron – Torpedo Bombers. Enemy shipping interdiction.
No 1 Air Ambulance Unit. DH8 transport aircraft.

In this short article, two examples of the operational success of these squadrons must suffice. So successful was 450 Squadron in its ground attack role that the Germans named them the ‘Australian Harassers’. In its mercy role during the final desert campaign alone, the Air Ambulance with its handful of aircraft operating from a succession of forward airstrips evacuated over 600 patients to base hospitals in one month. The total number it evacuated was 4679, a high percentage of whom could have died without speedy hospital treatment.

Following the invasion of Sicily in July 1943, Davies and McNamara accompanied 450 Squadron to an airfield near Augusta south of Catania, before landing on the Italian mainland.

Landing at Toronto about thirty six hours after British paratroopers secured the city; McNamara became Catholic chaplain to all the squadrons of the Desert Air Force operating in Italy. Next morning he celebrated Mass for a combined Italian and Allied congregation at an airfield near Toronto. To his surprise, for the occasion an elaborate outdoor altar had been erected, decorated with the Italian flag and flanked by an Italian Army guard of honour.

The Germans responded swiftly to the Italian surrender and had quickly sealed off the beachheads and furious fighting took place, especially at Salerno, before the Allies had a firm foothold on the mainland. Many civilians fled from the battle area, and the plight of these homeless refugees was particularly distressing, bringing home as it did the brutal reality of war. McNamara’s reports to principal RAAF chaplain in Melbourne commented much on the futility of war. His most vivid impressions, shared he says by other Australian airmen, was, ‘the extreme fortitude, courage, endurance and determination of the Italian women [very often their menfolk were Prisoners of war (POWs) overseas]. It instils one with the highest admiration for them.’

In September 1943, both Davies and McNamara were the only chaplains in the RAF Wing in which the RAAF squadrons were operating, and on Battle of Britain Sunday Rev Davies conducted a combined Divine Service for Anglicans and Protestants while Fr McNamara celebrated Mass for Catholics. Shortly afterwards Fr McNamara returned to North Africa and resumed his duties there. He was to make three long visits in all to Italy and on one of these he accomplished his third long cherished dream – a visit to Rome.

While at Bari, knowing that Fr McNamara was returning to Egypt, the Officer Commander Air Ambulance asked him to present to the Air Officer Commanding, a request for the replacement of the DH8s with more modern aircraft and the chaplain had accepted. But first he had to visit Australian airmen in the Tunis area. There was another reason for this visit.

Although the North African campaign had ended, the airfields along the long coastline remained operational. In addition to its strategic role against southern Europe, a further strain was placed upon some of the Australian airmen as the air war against the Axis powers intensified. Allied bombers operating from England began ‘shuttle bombing’ – attacking targets in southern France and northern Italy and having done this, continuing on to bases in North Africa. Then having rested the crews, refuelled, rearmed, and checked the aircraft (repairing where necessary), would attack targets on the return flight to England. This resulted in greater demands on all personnel; and aircrew casualties mounted both from operations and accidents. Chaplains were in great need.

In the Tunis area many squadrons are located. On this group there are Australian Air Crews. In fact, the Group is predominantly RAAF... Therefore in time it will be an Australian Group. The record of [the] RAAF in these Squadrons is very great and something we can be proud of... [But] we have lost a lot of lads, especially in recent months mainly through bad weather over Northern Italy.

Speaking also for his confreres, he continued:

The welcome a chaplain gets on a Squadron is most encouraging. They go out of their way to entertain you and make you feel one of themselves. The eagerness to go to Mass and Communion too is most encouraging. Not only is it from Catholics but from all. They have many problems which one can straighten out easily. One of the problems confronting those lads coming out from England is pay. Therefore I brought a Pay Sergeant with me.

A short visit to Cairo followed, where he delivered the request from the Air Ambulance to the AOC. Fr John could be easily forgiven if he carried out a mission of his own. Securing the services of his driver Leo Hanley, and then carrying various items of mail, he returned to Italy. Back in Bari he reported on his mission to the OC Air Ambulance, and delivered a letter from a nun in Cairo to her Italian mother. Then he returned to Tunis where he celebrated nativity Mass for 'Australians, Americans, Canadians, English, Scots, Irish, French and South Africans,' after which he help serve Christmas dinner. On conclusion of his visit to Olyda on New Year's Eve and having completed his round of visits, he set out for Cairo, reaching there on 11 February 1944. He had stayed for nearly a week at Gambut, a large Joint station which flew air sea rescue missions, operational sorties with Beaufighters and Marauders and American squadrons flying Mitchell heavy bombers. Of all the Australian squadrons that had been in this area only six months previously, only 451 Squadron remained. Because of the desperate need at Gambut for one of his calling, Fr McNamara remained for nearly a week conducting services every day and officiating at a funeral. He reported to Melbourne, 'There is no priest on the drome, something I have rectified since my return to Cairo'. But he had some good news in Cairo; 1 Air Ambulance was to return to Australia.

From Cairo he again visited the stations in Palestine and Iraq. But first he made a tour of the Stations along the Suez Canal; mainly El Firdan, El Ballah, Deversoir and Kasfareet.

The area was 'teeming with Aussies', who were tour expired aircrew acting as instructors at operational training units (OTU) or air crew taking an OTU course before returning to operations, or waiting to take an OTU course. However, it was being in Palestine at Eastertide, where he walked the Via Dolorosa on Good Friday and celebrated the Holy Eucharist on Easter morning that gave him greatest joy. Like most chaplains' of all denominations who served in the Middle East, Fr McNamara visited the holy places of Christendom during which he made a particular point of going to the Abbey of Abu Gosh, where there was an altar presented to the Abbey by chaplains of the Second AIF before leaving the Middle East for the Pacific war.

In addition to visiting the stations at Ein Shemer and Lydda, courtesy of the RAF, Fr McNamara was able to fly to Habbaniya near Baghdad and thus saved much time before his return to Italy.

During the battles for Rome, numbers 3 and 450 Squadrons which were based at San Angelo, sustained severe losses in planes and aircrew. Fr McNamara toured the bomber squadrons with Fred McKay – these were the squadrons attacking the enemy southern flank. Over a long period of operations these squadrons suffered 50% losses; as with all aircrew casualties, almost all dead.

The jobs and targets these lads have done are nothing short of extreme heroism. You can notice the strain telling on them, they may even be mentally unfit for operations but no one seems to take any notice of that – they still go on with the job. These lads have all my sympathy.

One example quoted by Fr McNamara was one of his own flock, pilot Jackie Wells, and his crew, who were awarded the Polish equivalent of the Victoria Cross for landing in Poland with supplies for the Polish underground army, then flying out senior Polish officers. The mission necessitated flying with pin point accuracy to a makeshift airstrip 800 miles deep in enemy held territory and landing a heavy bomber without radio guidance. On completion of the mission the entire crew were flown to England to be decorated. When Fred McKay returned to Cairo, Bob Davies continued the tour with the other 'Mac'.

Although aircrew losses were high they could have been heavier but for the assistance given by Italian partisan to Allied airmen who bailed out behind enemy lines. McNamara's saddest duty was to

perform the burial service of aircrew killed when their aircraft crashed landed or were shot down. An extant photograph shows him leading the cortège at a funeral near Cassino. Since this duty could also entail travel to distant crash sites, he took with him a photographer, whenever one was available, to photograph the grave for the next of kin.

On those long distance journeys in the spring and early summer of 1944, John McNamara witnessed the rebirth of the Italian countryside and compared it with Australia at that time. Writing about fields bordered with poplar trees, thick with wheat, barley and lucerne, and with grape vines threaded around wire stretching from tree to tree, Fr McNamara asserted, 'One would never see such rich and intense cultivation at home.'

In early June 1944, accompanied by an Australian official photographer, Laurie Le Guay, John McNamara journeyed to a distant Apennines military cemetery. There they erected a cross, prayed over the grave of an Australian who had crashed, and photographed it. While returning to base, their vehicle became caught up in an American convoy thundering towards Rome. It was the 6th June 1944 and the Eternal City had been entered by troops of the American 5th Army just two days before. The situation presented a temptation impossible for the Australian party to resist. They resolved to visit the Eternal City. In a letter to the RAAF principal Catholic chaplain, Fr John described the route and expressed the profound joy he felt on the visit.

Soon after passing Lake Albano and Castelgondolfo, flying the Papal flag, we could see the Dome of St Peter's outlined on the distant horizon. What a day this was for me - the third ambition of my life since ordination realised. To see Ireland, Palestine, and now Rome!.... We crossed the River Tiber and soon were in the piazza of St Peter's. There were very few people here, the main doors were closed and the fountains were leaping gaily in the quickly fading sunlight. We were really in Rome... the dome of St Peter's loomed majestically in the sky. We were the first Australians to enter the city and were fully conscious of the privilege.

Reluctantly we left the piazza - passed again over the Tiber, round the walls to Piazza di Popolo, passed the Colosseum and the Arch of Constantine then out through St Paul's gate back to the Highway 7, and at 8.30 were on our way home again with a real happiness in our hearts.

When the Allied front advanced north of Rome, the air force support squadrons naturally moved to forward air fields; and the RAAF squadrons took over the Italian experimental station at Giuromonia, fifteen miles north-east of Rome. Shortly after their arrival Fr McNamara celebrated two well attended Masses in a local church. During the second Mass a choir accompanied, and a girl sang *Ave Maria* 'like only Italians can sing it.'

Rome had been cut off from the English speaking world for years and following its liberation from the Nazis, world leaders, Church, political and military, flocked to the city. To control the influx, Rome was officially placed out of bounds. However, one of the Australian squadron commanders, Squadron Leader Ray Hudson, asked Fr McNamara to take a party of airmen to visit the city. He accepted with alacrity and the following day took two large parties into the city; one in the morning and one in the afternoon.

Early next morning we were on our way; anticipating with some anxiety the result of our venture. However there were no obstacles and we went all over St Peter's. It is without doubt the most impressive place in the world. We were amazed at mosaics, carvings in marble, height of the dome, the worn toe on the foot of the statue of St Peter. We walked all over the roof - looked down upon the Vatican City and gardens from the dome 420 feet above the Piazza. ... We went back to camp at 10 o'clock and brought the remainder of the boys in during the afternoon to see the sights. They were all very happy and impressed and asked hundreds of question about the Vatican and St Peters.

At Propaganda College the airmen met eight Australians, priests and students, who were overjoyed at meeting fellow countrymen; all were keen to visit the RAAF squadrons. Shortly afterwards, all the Catholics of the squadrons were given permission to attend Mass in St Peter's celebrated by Fr McNamara in a side altar: 'It was as good as a mission ... Chaps who hadn't been for years went to

the Sacraments'. Later the Australians were part of a congregation of thousands of Allied soldiers of diverse nationalities at a Papal audience. Fr McNamara was delighted to have had a brief conversation with Pope Pius XII. 'Never was I so happy – many were crying with happiness around me, Generals as well as Privates.' Then, after being allowed a rare visit to the Sistine Chapel, guided by Fr Gus Parker, a Lismore priest at Propaganda, the RAAF party toured the catacombs of St Callistus. Next day the squadrons returned the hospitality by hosting a visit of the Australians priests and students, showing them their aircraft, to the extent of demonstrating controls in the cockpits with engines running. It goes without saying that upon the conclusion of the memorable occasion, the visitors departed with Australian papers and suitable presents.

When Operation Dragoon was mounted in August 1944, against the south of France, 451 Squadron landed at Ste Tropez and advanced northwards. Bob Davies and John McNamara accompanied and remained with 451 for about a month. However, with Paris liberated and the Germans in full retreat towards the Rhine, the two chaplains declined an invitation to visit Paris, returning instead to Italy where duty lay.

Despite the protestations of the Allied Comander in Chief, Field Marshal Alexander, American and British Divisions were drawn off to take part in landings both in Normandy and southern France. Allied ground offensive operations Italy came to a grinding halt; but air warfare continued with all its attendant losses. Morale boosting was never so necessary. In the winter and spring of 1945 the chaplains' organised sporting events; Aussie rules football was favourite and a league featuring the RAAF squadrons was highly diverting from operations. At the end of the war in Europe, 3, 450, 454, 458 and 459 Squadrons, RAAF were concentrated near Udine close to the Yugoslav border. Surveying his tour of duty at this time, it was a matter of particular pleasure to John McNamara to reflect on the professional success of the RAAF in operations alongside their peer groups of other allied air forces. He mentioned in particular Brian Eaton, who had arrived in the Middle East as a Flight Lieutenant and rose to Group Captain with the DSO, DFC and Bar, commanding 239 Wing RAF.

At Udine the chaplains organised tours to places of interest such as Venice and over the Alps to Vienna until all three chaplains were recalled to Egypt. With the end of the war in Europe, repatriation of RAAF to Australia began, and following the cessation of operations there had been a decline in morale amongst personnel in Egypt. Therefore, all three chaplains were needed in Egypt to help organise welfare activities to counter this. McNamara was in Egypt on Anzac Day 1945, the 30th anniversary of the landings at Gallipoli. To commemorate the occasion and bid a sad farewell to fallen comrades, a service of remembrance was held at the El Alamein cemetery. As many as possible of the Australian servicemen and women then serving in the Middle East were assembled. Major General Allen (who had commanded 16 Brigade in the desert and Greece, then 7th Division), commanded the parade and following an address he handed over to Rev McNamara to conduct a combined service of remembrance. Following this, General Allen laid a wreath at the foot of a mast flying the Australian flag at half-mast. The last post and reveille were sounded and the flag rose to full-mast. Inspection of the 1300 Australian graves followed.

Shortly after the ceremony at El Alamein, Rev McKay and Fr McNamara returned to Italy. By this time only three RAAF squadrons remained in the command, 3, 450 and 454 and the Desert Air Force was disbanded. In a ceremonial fly-past to mark the occasion, 3 and 450 had the honour of leading with 454 Squadron in the rear. In August, just as peace came to the Pacific, all remaining Australian personnel in Italy were withdrawn to Egypt to await repatriation home. While at Toronto awaiting shipping, McKay and McNamara were again hurriedly recalled to Egypt and flew there on 27 August and were dispatched immediately to RAF Kasfareet, a major transit camp near Suez. There, over 1000 'browned off' Australians were awaiting shipping space. Bob Davies had just departed with a large contingent on the voyage homewards, and the two Macs were badly needed to organise activities, religious, sports and visits to restore morale. By October 1945, the last Australian airmen had left for home.

Few chaplains can have travelled as widely, ministered as effectively to such a diversity of nationalities, or had so profound an influence for good as that achieved by Bob Davies, Fred McKay and John McNamara during 1943-45. Theirs was a notable contribution to the morale of the RAAF in the Middle East at a crucial time. It was also a shining example for ecumenism before that word had gained its current coinage.

Notes

1. This article is based on reports by Chaplain J P McNamara to Staff Chaplain (RC) Headquarters RAAF, Melbourne, dated between July 1943 and October 1945 together with John Herrington's *Air War against Germany and Italy 1939-43* and *Air Power over Europe 1944-45*, AWM Canberra.
2. One of the visitors to Rome in 1944 was Field Marshal Sir Alan Brooke, the CIGS – an Ulsterman. While touring the catacombs just before his private audience he fell and damaged an Achilles tendon. He was in agony but determined not to miss the appointment; he accepted his batman's soldier's remedy for pain, a large medicinal brandy. 'I am afraid I must have created a very poor impression I am certain the Pope wrote me off as one of those drunken Orangemen from the North of Ireland ... in any case he was certainly quite charming and never disclosed his feelings.' Arthur Bryant. *Triumph in the West*. London, p526-7.
3. Charles Tingwell who after the war became a TV and film actor in Australia, Britain and Hollywood, was one of the Aussies in Tunisia. As a Spitfire pilot in 680 PR Squadron RAF he flew 75 operational missions. Photo reconnaissance squadrons flew stripped-down unarmed aircraft for greater speed.

-oOo-

Sabretache Writer's Prize and New Writer's Prize

Federal Council are pleased to announce that the *Sabretache* Writer's Prize and New Writer's Prize will now be awarded annually and the details of the 2012 Prize will be announced in the December issue of *Sabretache*.

The joint winners of the ***Sabretache* Writers Prize** for 2011 are:

Graham Wilson (ACT Branch) *Accommodating the King's Hard Bargain*. Australian Army Detention Facilities in World War Two; and Janet Hunter (Albury Branch), *The Pen is Mightier than the 'Bren'*: the wartime communiqués of Mate's Ltd Albury, 1941-1945.

Graham and Jan will be invited to speak at the 2012 Conference and their articles will appear in *Sabretache* in due course.

The winner of the *Sabretache* Writers Prize Encouragement Award was Andrea Gerrard (Tasmanian Branch) *Too good for the beastliness of War: Captain Ivor Stephen Margetts MID*.

The winner of the New Writers Prize was Andrew Pittaway (WA Branch); *Imperial Reservists from Australia* which appeared in the March 2011 *Sabretache*.

The Federal Council wishes to acknowledge the generous support of the Army History Unit and Big Sky Publishing in providing complimentary prizes of books to all the winners.

Rohan Goyne
Federal President

OF MAN AND MACHINE: TO WHAT EXTENT CAN TECHNOLOGICAL DETERMINISM APPLY TO WARFARE SINCE 1850?

Kevin L Davies

*It is not the technology itself, but the response to it that drives change –
Professor Jeremy Black¹*

Professor Black's comments are in relation to technological determinism in a military context – the hypothesis that technologically superior *often* or *always* guarantees victory in combat.² From the Crimean War through to the Vietnam War and the Russian invasion of Afghanistan, technology has been developed to defeat opponents on the battlefield, overcome environmental obstacles and clear the fog of war. As the endlessly varied, kaleidoscopically changing succession of equipment employed in war indicates, technological inventiveness has always played an important role in military affairs.³ Despite this important role, technology by itself cannot determine the outcome of warfare because warfare, and the combat that takes place during it, involves far more than just an exchange of new and improved weapons.

Given the context of Black's comment in relation to warfare, it is clear that no single piece of technology by itself has changed the outcome of a battle since 1850. Instead the side that wins is the side that is able to best comprehend the *totality* of all the factors involved – technological, political, economic, logistical, environmental, strategic – and then uses them to their advantage.⁴ All the technology available could not stop the humiliation of the United States by highly motivated North Vietnamese peasants, nor the Red Army by the horse-mounted mujahedeen in Afghanistan. In both cases technology played a role in bringing about victory – the Vietnamese with their access to Soviet technology and the Mujahedeen using surface to air missiles to bring down Soviet helicopters, but, as the Americans and Russians discovered, there is no weapon or technology so perfect that it cannot be countered with appropriate organisation, training and doctrine – so it is therefore unwise to place complete faith in technology to defeat an opponent.⁵ Both the Americans and Soviets were taught that all the military technology in the world cannot change the failure to understand the nature of the type of warfare they were engaged in.

By emphasising the importance of technology, not the response to it, there is a self evident failure to acknowledge the problem of when technology fails or its development produces a false-positive – an incorrect emphasis placed on specific piece of technology.⁶ Following the famous Battle of Hampton Roads in March 1861, when the USS *Monitor* engaged the CSS *Virginia/Merrimac* in the first ironclad naval battle, there was an emphasis placed on the importance of the ram because it was believed that the armour of the new vessels was so strong

¹ Black, Jeremy, 'Determinisms and Other Issues,' in *The Journal of Military History*, Vol. 68, No. 4, (Oct. 2004), pp. 1217-1232, p. 1220, viewed on 08 March 2011, <<http://muse.jhu.edu/journals/jmh/summary/v068/68.4black01.html>>.

² Watts, Barry D., 'Doctrine, Technology and War,' in *Air and Space Doctrinal Symposium*, Maxwell AFB, (Montgomery, 30 April – 01 May 1996), viewed on 28 March 2001, <<http://www.airpower.maxwell.af.mil/airchronicles/cc/watts.html>>.

³ Crevald, Martin van, *Technology and War – From 2000 B.C. to the Present*, (New York: The Free Press, 1989), p. 217.

⁴ Crevald, *Technology and War*, p. 229.

⁵ *Ibid*, p. 228. Archer, Christon I., Ferris, John R., Herwig, Holger H., Travers, Timothy H.E., *World History of Warfare*, (Lincoln: University of Nebraska, 2002), p. 202.

⁶ Black, *Determinisms*, p. 1221.

as to render gunnery almost useless.⁷ This emphasis ignored the unique nature of the naval battles of the American Civil War, whereby the fighting often took place in rivers and coastal areas that made manoeuvring difficult. The belief in the importance of ramming, as an example of a technological false-positive, was only further enhanced during the Battle of Lissa in 1866. Following the battle, great importance was placed on the sinking of the Italian *Re d'Italia* after being rammed by the Austrian *Ferdinand Max*. This importance, however, overlooked the fact that the ramming only occurred after the *Re d'Italia* was left rudderless and unable to move after being hit by fire from multiple Austrian vessels.⁸ By determining that the ram was the most important factor in ironclad warfare, too much emphasis was placed in a weapon that was actually quite peripheral to the future of naval warfare and ignored a far more important development—the turret.⁹ Another example of a technological false-positive was the 'monitor-fever' that infected the Union following the Battle of Hampton Roads.¹⁰ This fever resulted in large numbers of monitors being produced and used for roles, like fort-shelling, that they were hopelessly inadequate for.¹¹

In order for a piece of technology to be able to change warfare, it has to be 1) introduced, 2) used and 3) used correctly. During World War II (WWII) Germany developed impressive weapons systems, but few of the famous secret weapons ever saw combat.¹² The failure of the French to use the mitrailleuse correctly during the Franco-Prussian War and the British to capitalise on the breakthroughs made by the tank at Cambrai in 1917, both as a result of secrecy and overall inexperience, demonstrate that technology is as only as good as its users and cannot change anything by itself.¹³

The final argument against the notion that technology itself is responsible for change is the speed with which any single piece of technology is quickly countered or offset by the opponents' technological superiority in another area. According to Van Crevald:

In long wars between major, advanced powers a kind of seesaw effect tended to become manifest. As each side tries to leap frog the other, the advantage obtained [is] usually too temporary, or too limited in scope, to prove decisive before counter measures [can] be devised.

Though the seesaw effect can be observed at work in all major wars since 1861, at no time was its role greater than in World War II...the war neither witnessed a clear technological superiority on one side nor was the outcome decided by it. If the British constructed the first operational air defence radar system, it was the Germans who led in the field of electronic navigational aids for bombing. If the Allies built the most power internal combustion engine, the Germans pioneered the revolutionary jet and rocket engines.¹⁴

Van Crevald's comments make it clear that it is impossible for technology to change the outcome of warfare as it does not take long for an opponent to quickly develop a countermeasure for it.

⁷ Greene, Jack and Massignani, *Ironclads at War – The Origins and Development of the Armoured Warship, 1854-1891*, (USA: Da Capo Press, 1998), p. 118. The main reason why the guns failed to penetrate was due to, in the case of *Monitor*, the reduction of the amount of powder used for fear of the guns exploding. In the case of the Confederacy, the *Virginia/Merrimac* was only carrying explosive shells – useless against the armour of an ironclad. Konstam, Angus, *Hampton Roads – First clash of the Ironclads*, (Great Britain: Osprey Publishing, 2002), p. 73-74.

⁸ Greene, *Ironclads*, p.232.

⁹ This is not to say navies of the world ignored the overall importance of the ironclad – the remains of the USS *Cumberland* and USS *Congress* made it plain that the no wooden ship stood a chance against an ironclad.

¹⁰ Greene, *Ironclads*, p. 80.

¹¹ *Ibid.*

¹² Archer et al., *World History*, p. 514.

¹³ Crevald, *Technology and War*, pp. 227-278.

¹⁴ *ibid*, p. 228.

No single piece of technology, no matter how advanced, can win a war. Rather, each individual piece of technology must be fused into the whole – political, economic, strategic – for it to have any effect. Technology is developed to provide solutions to problems and warfare will evolve as a result. In warfare that problem may be the need to transport troops further and faster, strike hardened targets deep within enemy territory, or simply provide commanders with better and more reliable intelligence with which to make better decisions. All technology does is provide a solution to specific problem and must be developed or used according to a well defined strategy.¹⁵ In other words, it is professionalism, standardisation, and projection of superior resources, and dozens of other things besides weapons technology, which make the difference.¹⁶ Focussing on a specific piece of technology, such as the ironclad ram, may serve to blind militaries to other more consequential, though less obvious factors or technologies.

Bibliography

Archer, Christon I., Ferris, John R., Herwig, Holger H., Travers, Timothy H.E., *World History of Warfare*, (Lincoln: University of Nebraska, 2002).

Bingham, Price T., 'On Machine Guns and Precision Engagement,' in *JFQ*, (Summer 1997), pp. 88-90, viewed on 29 March 2011, <http://www.dtic.mil/doctrine/jel/jfq_pubs/1616pgs.pdf>.

Black, Jeremy, 'Determinisms and Other Issues,' in *The Journal of Military History*, Vol. 68, No. 4, (Oct. 2004), pp. 1217-1232, p. 1220, viewed on 08 March 2011, <<http://muse.jhu.edu/journals/jmh/summary/v068/68.4black01.html>>.

Black, Jeremy, *War and the World – Military Power and the Fate of Continents*, (New Haven: Yale University Press, 2000).

Cohen, Eliot, 'A Revolution in Warfare,' in *Foreign Affairs*, Vol. 75, No. 2, (March – April 1996), pp. 37-54, viewed on 27 February 2011, <<http://www.jstor.org/stable/20047487>>.

Cohen, Eliot, 'Technology and Warfare,' in John Baylis, James J. Wirtz, Colin Gray (eds.), *Strategy in the Contemporary World*, 3rd Edition, (Oxford: Oxford University Press, 2010).

Crevald, Martin van, *Technology and War – From 2000 B.C. to the Present*, (New York: The Free Press, 1989).

Crevald, Martin van, *The Transformation of War*, (New York: The Free Press, 1991).

Dyer, Gwynne, *War: The new edition*, (Carlton North: Scribe, 2004).

Haycock, Ronald and Nielson, Keith (eds.), *Men, Machines & War*, (Ontario: Wilfred Laurier University Press, 1988).

Head, Richard G., 'Technology and Military Balance,' and *Foreign Affairs*, Vol. 56, No. 3, (April, 1978), pp. 544-563, viewed 08 March 2011, <<http://www.jstor.org/stable/20039918>>.

Holley, Jr., I.B., *Ideas and Weapons: Exploitation of the aerial weapon by the United States during World War I; a study in the relationship of technological advance, military doctrine, and the development of weapons*, (Hamden: Archon Books, 1971).

Holley, Jr., I.B., (ed.), *Technology and Military Doctrine*, (Alabama: Air University Press, August 2004).

Jones, Archer, *The Art of War in the Western World*, (Urbana: University of Illinois Press, 2001).

Gat, Azar, *War in Human Civilization*, (Oxford: Oxford University Press, 2006).

¹⁵ Black, Jeremy, *Determinisms and Other Issues*, p. 1222.

¹⁶ Raudzens, George, 'War-Winning Weapons: The Measurement of Technological Determinism in Military History,' in *The Journal of Military History*, Vol. 54, No. 4, (Oct. 1990), pp. 403-434, p. 414, viewed on 03 March 2011, <<http://www.jstor.org/stable/1986064>>.

Greene, Jack and Massignani, *Ironclads at War – The Origins and Development of the Armoured Warship, 1854-1891*, (USA: Da Capo Press, 1998).

Greenwood, Ted, 'Why Military Technology is Difficult to Restrain,' in *Science, Technology, & Human Values*, Vol. 15, No. 4, (Autumn, 1990), pp. 412-429, viewed on 08 March 2011, <<http://www.jstor.org/stable/68921>>.

Johnson, Lee (ed.), 'France 1940 – Blitzkrieg in the West,' in *Osprey's Battles of World War II*, No. 2, (London: Hothouse, 2009).

Kaldor, Mary, 'The Weapons Succession Process,' in *World Politics*, Vol. 38, No. 4, (July 1986), pp. 577-595, viewed on 03 March 2011, <<http://www.jstor.org/stable/2010167>>.

Kaszuba, Lt. Col Karl A., USAF, *Military Technology: Has it Changed the Rules of Warfare?* (Maxwell AFB: Air War College, April 1997), viewed on 29 March 2011, <<http://oai.dtic.mil/oai/oai?verb=getRecord&metadataPrefix=html&identifier=ADA399023>>.

Konstam, Angus, *Hampton Roads – First clash of the Ironclads*, (Great Britain: Osprey Publishing, 2002).

Mendelsohn, Everett, Roe Smith, Merritt and Weingart, Peter (eds.), *Science, Technology and the Military*, (AA Dordecht: Kluwer Academic Publishers, 1988).

Murphy, Patrick, 'The Effect of Industrialization and Technology on Warfare: 1854 – 1878,' in *MilitaryHistoryOnline.com*, (2006), viewed on 23 February 2011. <<http://www.militaryhistoryonline.com/general/articles/effectofindustrialization.aspx>>.

Pape, Robert A., *Technological Sources of War and Peace: Why Structural Change Ended the Cold War Peacefully*, (University of Chicago, 11 April 2001), viewed on 23 Feb 2011, <http://web.mit.edu/ssp/seminars/wed_archives01spring/pape.htm>.

Raudzens, George, 'War-Winning Weapons: The Measurement of Technological Determinism in Military History,' in *The Journal of Military History*, Vol. 54, No. 4, (Oct. 1990), pp. 403-434, p. 414, viewed on 03 March 2011, <<http://www.jstor.org/stable/1986064>>.

Roland, Alex, 'Technology and War: The Historiographical Revolution of the 1980s,' in *Technology and Culture*, Vol. 34, No. 1, (January 1993), pp. 117-134, viewed on 27 February 2011, <<http://www.jstor.org/stable/3106459>>.

Roland, Alex, 'War and Technology,' in *Footnotes*, Vol. 14, No. 2, (February 2009), viewed 09 February 2011, <<http://www.fpri.org/footnotes/1402.200902.roland.wartechology.html>>.

Roland, Alex, 'Was the Nuclear Arms Race Deterministic?' in *Technology and Culture*, Vol. 51, No. 2, (April 2010), pp. 444-461, viewed on 09 March 2011, <<http://muse.jhu.edu/journals/tech/summary/v051/51.2.roland.html>>.

Shachtman, Noah, 'How Tech Changes Our Thinking About War' in *Wired.com*, (13 January 2009), viewed on 23 February 2011, <<http://www.wired.com/dangerroom/2009/01/how-tech-change/>>.

Shimshoni, Jonathan, 'Technology, Military Advantage, and World War I: A Case for Military Entrepreneurship,' in *International Security*, Vol. 15, No. 3, (Winter, 1990-1991), pp. 187-215.

Sleeman, C, 'The Development of Machine Guns,' in *The North American Review*, Vol. 139, No. 335, (October 1884), pp. 362-371, viewed on 03 March 2011, <<http://www.jstor.org/stable/25118427>>.

Travers, Tim, *The Killing Ground – The British Army, the Western Front and the Emergence of Modern Warfare 1900-1918*, (Wellington, Unwin Hyman Ltd, 1987).

Volkman, Ernest, *Science goes to War: The Search for the Ultimate Weapon from Greek Fire to Star Wars*, (New York: John Wiley & Sons, Inc., 2002).

Watts, Barry D., 'Doctrine, Technology and War,' in *Air and Space Doctrinal Symposium*, Maxwell AFB, (Montgomery, 30 April – 01 May 1996), viewed on 28 March 2001, <<http://www.airpower.maxwell.af.mil/airchronicles/cc/watts.html>>.

THOMAS WEMYSS JUST, INVENTOR

John Presser

While scanned pages were being edited for the National Library of Australia project to digitise old colonial newspapers, the following item was discovered as part of a 1916 article headed 'Warrant-Officer Porter Retires After 40 Years' Service':¹

The next (invention tested by Porter at Williamstown) was Ashton's dynamite gun - another failure after long trials. The Just (Tasmanian) pneumatic gun fired by compressed air was also failure. Rifles of all kinds, too numerous to mention have been tried, the most notable being the Ashton rapid-loader (Martini) but nothing came of it. Speaking of electrical targets, he considers the one invented by Captain Thomas T. Draper situated at the old range as being the most successful.



Thomas Cook Just
(Tasmanian Archives Collection)

The Captain Just mentioned is Thomas Wemyss Just, born 13 June 1864 at 46 Patrick Street, Hobart. His father was Captain Thomas Cook Just who was the Captain of the Cadet Rifles in Adelaide in 1861 and advocate of establishing a fife and drum band for the Adelaide Rifles.² The father was an accomplished actor and performer and may have moved to Hobart because of the opening of the Theatre Royal there.

On 1 April 1891, the newspapers reported that

a gun explosion occurred yesterday at Queenscliffe, Victoria. Corporal Charles Brearly and Gunner Donaldson were instantly killed, their bodies being fearfully mutilated. The following were injured: Lieutenant Moon, Bombardier Lighton, Gunners Duggon, Nott, Benbow, Dierson, Armour and Sergeant Turnbull. Gunner Brearly, was laying the gun, and Donaldson was beside him. They were standing shoulder to shoulder upon a little iron platform behind the gun, and were in the act of closing the breech block when the explosion occurred. The gun was supposed to be in perfect order, and, there is no satisfactory theory to account for the explosion.³

The accident at Queenscliff forts was during practice with a 6-inch central pivot gun. An explosion occurred following the jamming of the cartridge, and Gunners Brierly and Donaldson were killed. Both men were hurled a distance of several yards, the bodies being terribly mutilated. Seven other men were injured. The cartridge contained 41 lb. powder, and the shot, weighing 200 lb, was blown back into the fort a distance of 60 yards.⁴

London gunnery experts unofficially assert that the charge made against a colonial officer of requiring a tube to be inserted before closing the breach block would, if true, be sufficient to account for the gun explosion at Queenscliffe, Victoria.⁵

In 1892, Just, following[?] the enquiry following this explosion, patented a new invention, the Just Spherical Breech Action Gun, which he claimed would render this type of explosion impossible. His device was demonstrated at Queenscliffe by Captain J Noel Carey, RA.⁶

In 1894, in the Western Australian newspaper, the following prospectus appears.⁷

1 Melbourne *Argus*, 3 Jan 1916.

2 Prince of Wales Birthday, Volunteer Demonstration, South Aust. *Advertiser*, Tuesday 12 November 1861 and Meeting of Volunteer Officers, South Aust. *Advertiser*, Thursday 19 September 1861.

3 A terrible explosion, *West Australian*, Wednesday 1 April 1891, p. 4.

4 A terrible explosion, *West Australian*, Friday 3 April 1891, p. 3.

5 The Queenscliffe Gun Explosion, *West Australian*, Wednesday 17 June 1891.

6 New Zealand, News and Notes, *Hawera and Normanby Star*, 29 January 1892, p. 2.

PROSPECTUS
OF
'THE JUST PNEUMATIC QUICK FIRING GUN' COMPANY
(NO-LIABILITY)

(To be Registered under the 'Companies Act.')

CAPITAL ... £3,000 IN 8,000 SHARES OF £1 EACH.

3,000 Shares fully paid up to £1 each will be paid to the Inventor as part payment of purchase. 5,000 Shares are now offered for Sale privately at a subscription of 2s. 6d. on application and 2s. 6d on allotment. It is anticipated that it will not be necessary to call up more than 10s. per share in all, in calls of 2s. 6d. at intervals of not less than three months.

Provisional Directors: Lord Percy Douglas, The Hon. Sir James G. Lee-Steere, Kt., F. Connor, Esq., M.L.A., A. W. Hassell, Esq., Capt. T. W. Just.

Bankers: The Bank Of Australasia, Perth, W.A.

Solicitors: Messrs. Stone A Burt.

Secretary: Richard Sparrow, St. George's-Terrace, Perth.

Objects of the company.

The Company is being formed for the purpose of acquiring from Capt. T. W. Just his invention known as the 'Just Quick-Firing Pneumatic Gun,' and to dispose of it to one of the large firms of gunmakers, such as Sir William Armstrong, Mitchell & Co., Krupp Co., and others; or to sell the rights separately to the Governments of the Great Powers of Europe and in America.

It will be remembered that the Brennan Torpedo was sold for £110,000 to the British Government, and to this Company belongs a gun which will largely tend to revolutionise warfare. There is no report to speak of, no smoke, and no flash, and nothing to betray the locality from whence the terribly destructive projectiles come. It is the opinion of many that half-a-million of money will not be an outside figure to receive for the invention, which has been protected in Great Britain. This, under the Patents Convention, protects it in the principal countries of the world.

The price to be paid to the Inventor for his invention is:

3,000 Shares fully paid up to £1 ...	£3,000
Cash on confirmation of contract. ...	£1,000 Total £4,000

The Inventor is prepared, if so desired by the Shareholders in the Company, to place his Shares in trust. The balance of the money realised will be placed to the credit of the Company as working capital, to be devoted as it is subscribed to the payment and securing of full letters Patent for the invention, the working and floating of the Company, and sending Capt. Just to Europe.

A General Meeting of the Shareholders will be called by the Secretary when three-quarters of the Shares are sold, at which Directors, Bankers, Legal Manager, Solicitors and Auditors will be appointed.

THE INVENTION

A brief description of the Invention is as follows: - The object is to provide a Quick Firing Gun capable of propelling through the air quantities of explosives, etc, to various ranges with absolute safety without the use of gunpowder or primers of any description. This is obtained preferably by a projector or gun mounted on a suitable Field, Naval, or Fixed Carriage. For example, the material alteration of the present system of gun is, firstly, that the main breech-block does not require to be withdrawn from the rear of the gun more than a half turn, and never outside of the gun, unless for inspection or repairs.

The breech-block can be either a continuous or interrupted screw of any number of sectors, provided that the pitch of the threads is cut so as to allow of the block coming sufficiently to the rear to clear the

loading passage in the gun. Within the main breech-block a passage is drilled out, faced and ground up to receive a valve (vide plans) which is pierced preferably longitudinally - but can also be drilled circumferentially- to admit of the pneumatic propelling force to the charge.

An important feature of 'The Just Quick-Firing Pneumatic Gun' is in the construction, of the shell containing the high explosives Amide, Dynamite, etc., which is protected from premature explosion, and can only be fired on impact, or by properly constructed mechanical timefuse.

The advantages of rapid firing at a critical moment cannot be over-estimated, and it gain this the shells are preferably spherical in the small Quick-Firing Gun, but provision has been made for filling the hopper with conical tubes in the Quick-Firing Pneumatic Heavy Ordnance.

The 'Just Quick-Firing Pneumatic Gun' can be loaded in any degree of elevation, and can be loaded, elevated, trained and discharged by one person. The air pumps for small quick-firing ordnance are contained within a rotary disc casing, to which are attached the pedals and crank shaft of the compressors, which are operated by the gunner, who is supplied with seating accommodation in rear of the grim, and shield. The whole being attached to the main reservoir and mounted on gimbals can be carried round with the projector at the will of the operator. Plans may be seen and all particulars given to bona fide intending Share-holders by T. W. Just.

Following the success of pneumatic gun trials in the United States, the failure of his pneumatic gun in Victoria, and the success of the Australian Brennan Torpedo, Just began registering torpedo patents using the same pneumatic launch technology.⁸

In 1895, the press announced the newly invented 'Just' torpedo.

It is devised to do its work on the enemy both below and above the water line. And the two blows are delivered simultaneously. While one projectile is blowing out the enemy's plates and making an aperture for the water to rush in, the other is making things lively up on deck, or among the 'vitals,' so that should one-half the torpedo fail to 'get home' on the enemy, the other half can hardly fail to reach the mark with telling force; while, if both 'get home,' the consequences are almost certain to prove disagreeable to the most perfectly equipped warship afloat.

It is found that the Brennan, owing to its limited range (1000 yards), cannot prevent an ironclad fleet from destroying forts at a distance of 4000 yards, or shelling a dockyard at double that distance. It is simply a torpedo held in a leash covering a small circle of water, which must be entered to bring it into operation. It is looked upon by an enemy simply as an obstacle to be avoided, as the movements of the torpedo can be followed with scrupulous fidelity by machine guns fire as well as by the human eye.

Captain Just's torpedo will not embarrass but aid the operations of a fleet. Already the patent has been protected in Great Britain, the colonies, and in the principal countries of the world, and arrangements are now being conducted through the Victorian Agent-General in London for placing it in the hands of the Secretary of State for War, as a secret invention for the benefit of the Empire.

Captain Just has also been good enough to place his invention in the hands of the Victorian Government free of charge, for the protection of this colony, and it has been accepted by the authorities, and a transfer of the patent rights and full plans and specifications will be supplied to the department in a few days' time. What Captain Just, who is a Tasmanian, by the way, claims to have accomplished may be best described in his own words: - I have provided a compressed air projector for overhead torpedoes of extreme lightness, and also a torpedo which is uncontrolled by wires for action amongst submarine mines in our own defended harbours.

This latter will compare for cheapness and simplicity of details with the great expensive torpedoes now in use with their internal intricacy, delicacy of detail, and general unwieldiness. The 'Just' torpedo is so constructed that it attacks the opposing ship, not only below water, but also above, and both at the same time. Once the torpedo being discharged from the projector, one part of it falls into the water, whilst the other strikes the vessel above the water line or by descent on to the deck.

⁸ Pneumatic gun does rapid work, *New York Times*, 24 August 1894.

The range of the Just projector is superior to that of either the Brennan or Sims-Edison, and, besides, many Just torpedoes can be fired while one Brennan or Sims-Edison torpedo is being manipulated. The Just projector can fire its torpedoes over a mined area without damaging the mines, whereas the Brennan or Sims-Edison requires an area clear of buoyant or sunken mines.

Again, the Just torpedo can be directed on a vessel whose mast only is visible, the space around her being covered with the smoke of an engagement, whereas under similar conditions the Brennan or Sims-Edison torpedoes would be absolutely useless, because the operator could not see to direct them.

The Just projector has accuracy of range when firing at high angles of elevation, and the maximum of force is found perfect and capable of throwing with accuracy and uniform range large torpedoes of high explosives to greater distances than the extreme range of any movable torpedoes, such as the Ericsson, Lay, Berdan, Sims-Edison, The Nordenfeldt, The Patrick, The Lay-Patrick, Brennan, Howell, Whitehead, or Lego.

A leading feature in the armament of a warship provided with the Just projector is that it is unnecessary to send men away from the ship on a dangerous errand in a torpedo boat in the course of an action, perhaps in bad weather, and when the numerical strength of the crew and their unity may mean the success of their vessel. There is no highly finished or complicated machinery in the 'Just' to require constant attendance, and the projector is kept clean and efficient as easily as an ordinary gun.

The 'Just' projector having been already aimed under cover by reflecting mirrors, it is found that only a moment is required to make any necessary final adjustment of alignment, and to fire it leaves no trace to direct the return fire from an enemy's ship.

The cost of half-a-dozen 'Just' torpedoes, with their projector, is much less than one emplacement for Brennan or Sims-Edison system complete, with their intricate and expensive torpedoes, and the weight of the 'Just' torpedo is less than one-fourth of the others.⁹

In 1896, a meeting of the directors of the Just Torpedo Explosive Projector Company Ltd considered the offer from a London syndicate to purchase Captain Just's torpedo explosive invention for £40,000 cash, or an alternative offer of £50,000, half in cash and half in shares in a company with a capital of £500,000 which was being formed in London to manufacture torpedoes. It was decided to cable to the London agents to accept £25,000 in cash and £25,000 in shares fully paid up.¹⁰

This Just Double Headed Torpedo was a combination of projectile and sub-aquatic torpedo. Its diameter was 10 inches and its cigar-shaped body, 'tapered to a point at both ends', measured eight feet in length. However, the bow was double-cased with a two-foot-long detachable cap that mirrored the contour of the body shell, leaving the latter with its original tapered shape after the cap had separated. The torpedo was designed to be fired from a special deck gun and was provided with a small propeller and motor which was activated as soon as the main body entered the water. The nature of the engine was not revealed, nor were details of any depth-keeping gear which Just might have incorporated into the weapon. The body was made of aluminium and the device had a claimed range of four miles. It was not taken up by the British establishment.

In 1899, a double-propulsion controllable torpedo was invented by the ex-member for Williamstown, Mr W T Carter, who travelled to London to negotiate its sale.¹¹ Was this an improvement on Just's patent by Captain Carter?

Just, who had been living in Launceston, Tasmania and raised a family there, did not give up on his torpedo device. He took out an American patent No. 638,463 of 5th December 1899 and moved to New York. This American patent shows the projectile weapon to be substantially the

⁹ A new form of torpedo, *Brisbane Courier*, Saturday 21 September 1895.

¹⁰ A torpedo invention, *Brisbane Courier*, Thursday 31 December 1896 and *NZ Evening Post*, 31 December 1896, p. 5.

¹¹ Australian Celebrities, *West Australian*, Thursday 4 May 1899.

same as that already rejected by the Victorian and British Governments, and was assigned to Dr Mary Josephine Alsbau, a women physician of Brooklyn, New York. In the American press its inventor is noted as Captain Thomas Just, an Englishman and a former artillery officer who for many years had lived in Tasmania.

Mary Alsbau is described as inventing a part of the automatic device which controlled the torpedo when submerged. For manufacturing the projectiles a company with a capital of \$1,000,000 was incorporated in New Jersey. The company was to expend \$50,000 for experiments with the torpedo, and the United States Bureau of Naval Ordnance was asked to contribute \$10,000 of this amount. If the tests were satisfactory and the government wished to purchase, the company would sell its rights to the invention. Counsel to the company, which was known as the Just-Alsbau Torpedo Company, was the law firm of Root, Howard, Winthrop and Stimson, of which the secretary of war was a member.¹²

The patented guidance system and other details are further described in the American Press.

The torpedo consists of an ordinary casing similar to the Whitehead torpedo, to which is attached a false head, which in itself becomes a shell that is practically the same as a charge from a mortar and strikes the vessel above the water line. The main charge in the torpedo proper is projected at the vessel from beneath the surface of the water. Both missiles are hurled at the same time with the same charge of explosive.

One of these two projectiles is sure to the target owing to an arrangement of an electric application similar to the Marconi system of telegraphy, but which is controlled in such a manner that its force can be directed in a certain direction, instead of all around the compass, as in the case with the Italian's method.

The torpedo proper is propelled by liberating liquefied air through the discharge orifices to the electors, and forms a hydraulic jet which impinges against the water. The false head is temporarily locked to the main part the torpedo and when fired the bolts holding it are loosened so that they slide over the tapering head of the torpedo proper.

A hand wheel below the breech of the tube acts as a lanyard, and upon its being turned the pressure of air is forced between the 'sabot' and the projectile. The latter, being moveable, is forced forward. The torpedo has pins on either side at the point where it tapers off towards the false head that run in grooves in the barrel of the projector which steady the flight of the missile until it passes out from the muzzle.

By an automatic action, the key on the sabot releases the steering gear, which is the part that Mrs Alsbau has perfected. This gear consists of a pair of flanges on either side and a keel or vernal fin that drops down of its own weight as soon as the torpedo is released. The effective range of the torpedo is from one to two miles, and can be regulated accurately form the firing point. Should the roll of the vessel from which the torpedo is firing cause the missile to be driven forward at an angle that would preclude it from reaching the target, a lever, weighed on either side with leaden balls, turns the inclined planes on either side to such an angle that the messenger is kept just below the surface of the sea, is steered directly at the object aimed at, and by the electric magnets is propelled directly at the object whose destruction is contemplated, whether that object is a battleship drawing thirty feet of water or a small craft drawing but three feet.

12 Novelty in naval warfare, *Oswego Daily Times*, 19 December 1899.



US Patent 638,463 5th December 1899

Fig 1 is the combined torpedo and false head.
 Fig 2 is the actual underwater torpedo
 Fig 3 is the compressed air gun or projector
 to fire the double missile.

The Alsbau improvement seemed to be an attempt at getting around the successful Whitehead submerged depth guidance patents, also known as 'the secret'.¹³ The disadvantage of using torpedoes up to 1900 was that they were slower than the torpedo boats and the larger torpedo boat destroyers that launched them and too slow to outrun the torpedo launchers when used defensively. After 1900 or so, the free running torpedo that ran in a straight line replaced the 'controlled' torpedo types. A refinement to the free-running Whitehead torpedo allowed it to sink when fired armed, but to float to the surface for recovery, if used in practice. However, when the Tasmanian Torpedo Boat TB 191 fired one of her two Whitehead torpedoes in practice in Frederick Henry Bay, it was never recovered.

Details of Thomas Wemyss Just's service in the Colonial artillery branch in Tasmania have not come to light yet, despite extensive research.

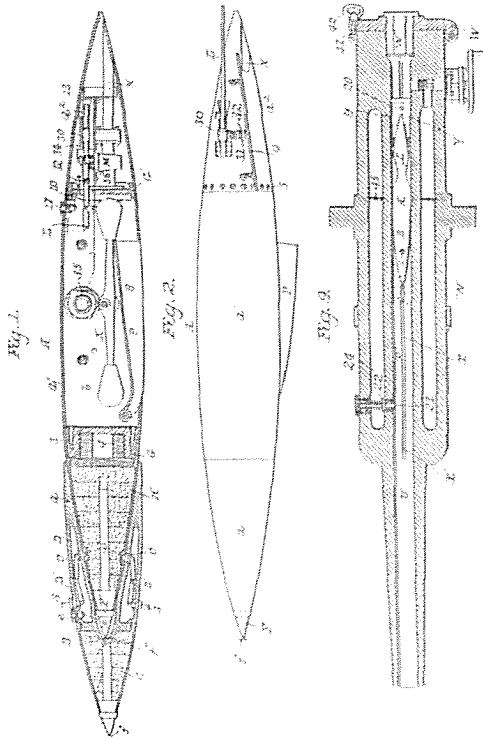
-oOo-

13 Woman perfects torpedo, the invention of Capt T W Just, *New York Times*, 17 December 1899.