

Military Historical Society of Australia  
*Sabretache*

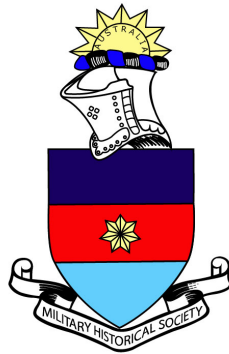

Copyright © 1957-2019 Military Historical Society of Australia on behalf of the Society and its authors who retain copyright of all their published material and articles. All Rights Reserved.

*Sabretache* policy is that the submission of material gives the Society permission to print your material, to allow the material to be included in digital databases such as the MHSa website, Australian Public Affairs-Full Text, INFORMIT and EBSCO. Reprints to non-profit historical and other societies will be approved provided suitable attribution is included and a copy of the reprint is sent to the author. Copyright remains with the author who may reprint his or her article or material from the article without seeking permission from the Society.

The Society encourages the download and distribution of *Sabretache* for personal use only and *Sabretache* can not be reproduced without the written consent of the Society.

[www.mhsa.org.au](http://www.mhsa.org.au)

Military Historical Society of Australia  
PO Box 5030, Garran, ACT 2605.  
email: [webmaster@mhsa.org.au](mailto:webmaster@mhsa.org.au)

*Clem Sargent 3165*  
~~SECRET~~ COPY FOR REFERENCE

# SABRETACHE

JOURNAL OF  
THE MILITARY HISTORICAL SOCIETY  
OF AUSTRALIA

*JANUARY - MARCH 1979*

VOL. XIX

OCTOBER 1978

No 4



Registered for posting as a publication Category B — Price \$3.50

*Delete - Not Paid*

# **P. J. DOWNIE**

## **PUBLIC COIN, BANKNOTE & MEDAL AUCTIONEERS**

We are the largest philatelic and numismatic auctioneers in Australia. If you are looking for the best in medals don't miss our listings. We hold bi-monthly Public Auctions of Coins, Banknotes and Medals and are sure to be offering material that will interest you.

**If you are looking to see your medals there is no better place.**

### **WE CAN OFFER YOU —**

- **Top market prices**
- **Cash advance (Interest free)**
- **Competitive Commission Rates**
- **Travel arrangements to collect valuable collections**
- **Immediate private treaty sales**
- **Payment in full 14-28 days following auction**
- **Confidential dealings**

### **WRITE TO US WITH YOUR OFFERINGS**

For our Auction Catalogues send \$1, or for subscription until the end of 1978 to our Coin, Banknote and Medal Auctions send \$5. Overseas rates on application.

**94 ELIZABETH STREET, MELBOURNE 3000**

**Phone: 654 3518 or 63 2503**

**Telegrams or Cables: Downiestamps, Melbourne**

✓

# "SABRETACHE"

JOURNAL AND PROCEEDINGS OF  
THE MILITARY HISTORICAL SOCIETY  
OF AUSTRALIA  
(FOUNDED IN MELBOURNE IN 1957)



Vol. XIX

OCTOBER 1978

No. 4

CONTENTS.

---

Simpson — The Man Behind the Legend By Nigel G. Fitzgibbon	5
Book Reviews - <i>fill in</i>	14
Tanks of the Past	17
To Battle on Bikes By J. R. Williams	26
Sergeant Made Banking History	40
All A Matter of Music	48

---

*Members Wants & Sales.*  
*Articles of Australian Military*  
*Historical Interest in Contemporary Journals.*

*- last pages.*

*Be*

Front Cover: Sgt. Slater, Worcester Regiment, story P26.

*Quarterly*

Published by authority of the Federal Council of the Military Historical Society of Australia. The views expressed in the articles in this Journal are those of the contributors and not necessarily those of the Society.

ISSN 0048-8933



# THE MILITARY HISTORICAL SOCIETY OF AUSTRALIA

## Patron:

General Sir John Wilton, K.B.E., C.B., D.S.O. ~~(idc, pso)~~ (R.L.)

## HONORARY OFFICE-BEARERS

### President:

Mr N. Foldi

### Vice-President:

Major H. J. Zwillenberg E.D. (RL)

### Secretary:

Lieutenant-Colonel T. C. Sargent (RL)

### Treasurer:

Mr J. M. Kennedy, J.P., A.A.S.A.

### Councillors:

Victorian Branch — Mr D. K. Trigar  
Geelong Branch — Major I. L. Barnes, E.D.  
W. Aust. Branch — Mr P. Shaw  
Qld. Branch — Mr J. H. Irwin  
Albury/Wodonga — Mr D. Campbell

*delete*  
→ *Centre*

### Editor:

Peter Kelly

The aims of the Society are the encouragement of study and research in military history customs, traditions, dress, arms, equipment and kindred matters; the promotion of public interest and knowledge in these subjects, and the preservation of historical military objects, with particular reference to the Armed Forces of Australia.

Membership is open to all, subject to payment of \$15.00 annual subscription (due 1st July each year). Overseas applicants are advised that airmail delivery of Sabretache is available for an additional sum of \$10.00 (all rates in Australian currency).

**Correspondence and contributions should be addressed to the Federal Secretary, P.O. Box 30, Garran, A.C.T. 2605.**

## BRANCH SECRETARIES

A.C.T. — Mr K. R. WHITE, PO Box 67, Lyneham, ACT 2602.

VICTORIA — Mr R. J. KIRK, 18 Osborne Court, Hawthorn, Vic.  
3122.

GEELONG — Mr J. P. MALJERS, 4 Stork Avenue, Belmont, Vic.  
3216.

ALBURY/WODONGA — Branch President: Mr D. CAMPBELL,  
131 Borella Road, Albury, NSW 2640

QUEENSLAND — Mr S. W. WIGZELL, 17 Royal Street, Alexandra  
Hills Qld. 4157

SOUTH AUSTRALIA — Mr K. STANLEY, 40 Deborah Grove,  
Modbury North, 5092.

WESTERN AUSTRALIA — Branch President: Mr. P. A. SHAW,  
Unit 2, 9 Streckland Street, South Perth, W.A. 6151.

## “FROM KHAKI TO BLUE”

The memoirs of Air Commodore R. J. Brownell, CBE, MC, MM. From the ranks of the 9th Battery, Australian Field Artillery, to fighter pilot in the Royal Flying Corps on the Western and Italian Fronts in World War 1, to a distinguished career in the RAAF during World War 11. With a Foreword by Air Marshal, Sir Valston Hancock, KBE, CB, DFC.

More than 200 pages of text, with some 40 photographs, most never before published. A must for collectors and historians. Price \$10.00 plus postage, \$1.00.

**Hurry, only 600 printed!**

*when it is available,*

# EDITOR'S NOTES

THE Royal Australian Armoured Corps Tank Museum was formed in 1970 using as a basis a number of vintage armoured vehicles which adorned the Puckapunyal Military Area.

The Museum was located in an unsealed, unprotected and unsheltered area to the east of the Armoured Centre.

From this rather humble beginning the Museum has expanded until today it has hard standing for all of the vehicles and indoor displays featuring classroom instructional models, weapon displays, radio displays, and a pictorial area.

The objects of the Tank Museum are threefold:

Firstly, to display the historical evolution of the tank; secondly, to provide information for the education of all ranks of the Royal Australian Armoured Corps; and thirdly, to provide a display of interest for the general public.

The exhibits are historic and irreplaceable items.

Any information concerning armoured warfare would be welcomed by the staff. On page 17 "Sabretache" begins the first of a series of tanks of the past.

Unpaid members ad.

## MHSA PENNANTS

Silk embroidered pennants bearing the Society's crest in full colours are available at \$12.50 each from the Albury/Wodonga Branch.

**(MONEY WITH ORDERS PLEASE)**

*The pennants (9" wide and 10" long) can be named to branches if desired.*

*Coat-pocket cloth badges are also available  
(Price enquiries to Albury/Wodonga Branch)*

*Members Sales & Work*

**JOHN Simpson Kirkpatrick was one of a multitude of ordinary men, who with incredible and unconscious heroism, turned the glorious failure at Gallipoli into a remarkable and national tradition — Anzac.**

## Simpson — the man behind the legend

by *NIGEL G. FITZGIBBON*

JOHN Simpson Kirkpatrick was born at South Shields, England, on July 6, 1892. His father, Captain Robert Kirkpatrick had sailed for 20 years as a mate and master in ships of the London and Edinburgh Line.

Illness was to strike the young family of four boys and a girl, and was to result in the tragic deaths of his three brothers from scarlet fever.

On completing secondary school, Simpson's teachers were to report that he was an ordinary boy who had little zeal for scholarship, but who delved in games, pranks and the occasional mischievous escapade.

He had a natural fondness for animals, and for some years as a lad had bred pet rabbits.

He was devoted to his dog, a Yorkshire terrier, and was indeed to become familiar with that misunderstood of all animals, the donkey.

Simpson as a schoolboy, twice yearly at the South Shields Fair, was to accept the tedious task of looking after these animals for sixpence a day. He was not to know that this experience with donkeys was to be a preparation for a role, in what would prove to be a critical and demanding situation, and which



★ ABOVE: John Simpson Kirkpatrick — a photo taken on his 21st birthday in Melbourne, July 6, 1913.

would result in the saving of many men's lives.

It was the family wish that John Simpson Kirkpatrick be accepted as an apprentice in engineering; but unemployment in 1906-1908 was widespread throughout England, and so he took on a job delivering milk, using a pony and float.



This job he was to hold for four years.

In 1908, Britain brought in military reforms, and introduced an Army Reserve — to be known as the Territorials. At 17 years of age, Simpson joined the Durham Howitzer Battery as a gunner. However, it was not long after this that his father died, and he then decided to follow the career of his father and went to sea.

His first ship was the S.S. "Heighington," which he joined as a steward, and for the next five months the ship was to ply the trade routes between Newcastle and Africa. This first experience away from home was to cause him great anxiety for his widowed mother and for his young sister Annie, in that he was to write letters to them regularly, and always with a couple of pounds for their financial support.

On February 12, 1910, Simpson changed ships, and joined the crew of the S. S. "Yedda."

The conditions of this ship were not good, and when a few months later the "Yedda" called at Newcastle, NSW, Simpson and 13 crewmen "jumped ship".

It was from this day on that he dropped the surname Kirkpatrick to hide his identity.

During the next 12 months, Simpson, having made his way to North Queensland, then took on his first job in Australia as a cane-cutter.

However, the extreme heat and poor wages caused him to seek alternative work.

With a mate, Simpson walked through the scrub for almost 150 miles to take on his second job as a station hand on a cattle property. This job lasted only briefly before Simpson made his way back to Cairns and was taken on as a

relieving ship's fireman on a coastal freighter.

Eventually, Simpson left the sea for a second time and went to Coledale and then to Corrimal, NSW, and worked as a coalminer.

He wrote regularly to his mother in England, and she felt great concern for his well-being in Australia.

The following letter is typical of the many he wrote to his mother.

Corrimal, NSW  
27th November, 1910

Dear Mother,

*Just a few lines to let you know that I am still alive and kicking ..... Now Mother what were you making such a song about those so-called hardships there was no hardship about it at all, it is just about the best life that a fellow could wish for 'carrying his swag' or 'Humping his bluey' as the colonials call it going all over the country with all your belongings strapped on your back that is your blankets a change of underclothing 'if you have got any' and a billycan.*

*Now Mother you will think that we would be like tramps in the old country, but what a mistake the best of respectable men with a house of his own, when he gets out of work he will just pack his swag and off he goes to where he hears the work is on.*

*Now Mother I am sending you a new year card I think that it will just about get home by about the New Year. I say I won't be home this Christmas to help you to eat that goose mind I did use to help with the goose if it was only to eat it.*

*I wish I was at Canny Old Shields for the Christmas this place is so quiet in fact I can feel my whiskers turning grey*

*already. Now Mother I hope you like this card. Now Mother I will now conclude with best love from*

*Your loving Son*

*Jack*

*PS. I am enclosing P.O. for a quid.*

Simpson stayed a few months at Corrimal, and then moved to Bullfinch, Western Australia, where he tried his luck in the goldfields, at Yilgarn.

Having experienced hardships there, Simpson travelled the long hitch of nearly 800 miles back to Fremantle, WA, and was fortunate enough to get a job as a steward on the coastal ship S.S "Kooringa," where he stayed employed for the next three years.

*No head lines*  
**SIMPSON ENLISTS**

When war broke out in 1914, Andrew Fisher, the Labor Prime Minister of Australia, pledged absolute support for Britain, as he declared: "To our last man and our last shilling."

Simpson was among thousands of men who flocked to recruiting offices in all States, all anxious to join the expeditionary force of 20,000 men which Australia had promised to send to Britain to fight on the Front in Europe.

Army records show that Simpson was a man of fair complexion, blue eyes, brown hair, 5 feet 8 inches tall, and approximately 12 stone in weight.

After some basic training at Blackboy Hill Camp, Western Australia, Simpson was appointed as a stretcher-bearer with C Section, 3rd Field Ambulance, Australian Army Medical Corps.

On the day of Turkey's entry into the war, on November 1, 1914 so too did 38

transports with escorting destroyers depart from Albany, WA, for England.

Simpson was on the liner "Medic," and much to the surprise of his mates, had brought along with him on board ship his pet possum, who was to share his hammock for the duration of the sea journey to the Port of Alexandria, Egypt.

Demands were soon to be imposed on Britain by Russia for some relief to be made available for her forces battling against the Turks in the Caucasus.

Winston Churchill who was then the First Lord of the Admiralty, had suggested the strategy of a naval attack on the Dardenelles Peninsula, which being successful would then open a direct sea communication with Russia.

His ideas were given strong support, and thus plans were to be put into effect which were to provide for the combined naval and military might of the Allied forces to attack the Turkish Forces at the Dardenelles, and to then hold and occupy this territory.

Australia's convoy of troops was now to be diverted and to disembark at the Port of Alexandria, Egypt on December 3, 1914.

To his mates in 3 Field Ambulance, and according to Capt. A. R. Davidson, DCM, MM, of Perth, WA, Simpson's character was that of being original, forthright, fearless, witty and generous-hearted.

Being at times careless of dress, and barely intolerant of unnecessary regimentation, he at times did prove to be a challenge to Sgt. Hookway, his Section Sergeant.

At Camp Mena, Simpson was to arrange for his mother to receive an allowance from his Army pay. The pay of an Australian private was five shillings a



### THE MAN WITH THE DONKEY

There are in existence few genuine photographs of John Simpson Kirkpatrick and his donkey — renowned for their gallant work of transporting the wounded under fire in Shrapnel Gully during the early stages of the Gallipoli campaign. Above is one, the best known to exist, taken by an officer of the Australian Army Medical Corps in which Kirkpatrick was serving. Known in the Army as Simpson, he was killed in action on 19 May 1915. Statues in honour of his bravery and humanity have been erected at the Australian War Memorial, Canberra, near the Shrine of Remembrance, Melbourne, and at his birthplace, South Shields, Durham.

day, with an extra one shilling a day deferred pay while on active service.

It was to be a great disappointment to Simpson that he was now to be denied the chance of ever seeing his mother again before going into combat.

## GALLIPOLI LANDING

After four months of hard training in the heat and desert sands at Camp Mena, near the Pyramids, the First Australian Division was then sent to the Island of Lemnos.

Thus, final preparation and training was undertaken in disembarking from ships to boats, then rowing ashore and assaulting the beach.

It was on the ship "Malda" that Simpson and his mates from 3 Field Ambulance became very disillusioned with the food that was served to them.

Simpson, bold and daring, led a small party below decks, and returned unobserved with some goodies, cheeses, Cambridge sausages, a large quantity of biscuits, plus some bottles in straw-wrappings, which they thought to be wine, but to their dismay, proved to be vinegar.

This provided Simpson and his mates their last decent meal, prior going into combat at Gallipoli.

The 25th of April, 1915, was a tranquil night lit by a half moon. Soon after mid-night, the troop transport ships arrived at their appointed rendezvous.

At approximately 1.30am, Simpson

and the other members of 3 Field Ambulance were transferred from the transport "Devanha" to the Destroyer "Ribble."

From the destroyers the men then descended into small boats and at approximately 4.30am, were rowed to shore.

Even before some of the boats reached the shore line, heavy firing was brought down by the Turks waiting in the low scrub just off the beach.

Before Simpson had jumped into the water, two members of his section of stretcher-bearers were killed outright.

It was still dark, just before dawn, and Australian troops in their hundreds rushed from the boats, and across the beach, took cover, paused for breath and shed their packs before their assault up the steep slopes to confront the enemy with rifle and bayonet.

The first days of the landing proved disastrous for the number of casualties sustained; notably by the 3rd Infantry Brigade.

Many troops were to die from exhaustion, due to the heat, lack of food and water, and from severe shock as a result of their injuries.

Regimental stretcher-bearers and AAMC personnel had also been drastically reduced.

It was at dawn on the second day, and Simpson had just carried two heavy wounded men, on his own, in succession, down the rugged slopes of Shrapnel Valley and through the Valley of Death

---

**ONE of Europe's most impressive war memorials is in the town of Ypres, Belgium, the Menin Gate. During the war there was no actual gate there — the site was occupied by two lion statues, one on each side of the roadway (one statue is now in the Australian War Memorial). Many soldiers passed the lions on the way to the front and were frequently heard to remark: "Tell the last man through to bolt the Menin Gate."**

*1 Bold Heavy type 2?*



and back to the Casualty Collection Post on the beach, when he caught sight of a donkey nibbling in one of the near-by gullies.

He approached the beast with confidence, and both it seemed were glad of each other's company.

From that day on they were to work as a team collecting casualties continuously, even in the face of heavy enemy action.

Lt. Col. Alfred Sutton, the Commanding Officer of the 3rd Field Ambulance, recognizing Simpson's value, had allowed him to continue this work, but only asked that he report at least once a day to the unit.

Depending on his mood, Simpson's name for the Donkey varied, but usually it was named, "Duffy," but sometimes "Murphy," and occasionally "Abdul."

It was on May 15, 1915, that General Bridges, whilst visiting his troops at Shrapnel Valley, was hit by a Turkish sniper.

While he was receiving first aid treatment from a Medical Officer, Capt. Thompson, Simpson came along, and

immediately offered the use of his donkey to transport the General back to the Casualty Clearing Post down at the beach.

The General declined the offer, stating that he did not want to put the stretcher-bearers at risk.

There was at least one occasion when Simpson did bring back an unwounded, but very hostile man to the beach.

One day he saw a figure moving in the bush and shouted: "Halt there. Who are ye?"

"I'm a warrant officer of the 3rd Field Engineers."

"Come out, then, and let's have a good look at ye," replied Simpson. He examined the suspect and boldly said: "I don't like the look of ye."

The Warrant Officer stared and said: "Don't be foolish, I'll report you. I'm making levels for the excavations for a new road here."

"Maybe, maybe, but ye'll come down with me to the station, all the same."

Arriving there, the Warrant Officer

## **REGAL COIN COMPANY PTY LTD.**

**P.O. Box 1896R, G.P.O. Melbourne**

**Suppliers of Numismatic items**

**Coins, Tokens, Medals, Medallions, Books and Accessories**

**SHOP 9 EMBANK ARCADE**

**325 COLLINS STREET, MELBOURNE, C.1 VIC.**

**Phone 03 62 1182**

**Wide Range of Medals Available. Regular Medal List.**

**Write now for your copy.**

**Constantly seeking medals for stock — Let's know what you have for sale.**

*Delete - not paid* 10

was, of course, identified.

"Oh, well," said Simpson turning to his Donkey, "he's dirty enough to be a Turk even if he ain't one, isn't he, Duffy?"

There have been numerous verbal and written testimonials given by men who were rescued by Simpson. The following is typical, given by a Gallipoli veteran, P. G. Menhennett:

*On the evening before our first attack on Quinn's Post (2nd May) we came down from Pope's Hill, which our battalion — the 16th — had occupied since the landing, to prepare for the dawn attack.*

*It was fierce and many of us were soon out of action and placed out of the line of fire for evacuation when possible. After a terrible night, daylight eventually arrived and soon after came Simpson.*

*Some of our cases were pitiful, but this cheerful Digger had a word and a smile for all.*

*He came to me and asked me what was wrong and when I told him I'd been shot through the right leg just above the knee, he asked me could I walk.*

*I told him I might have been able to a few hours earlier, had I known the way down, but now it had got cold and stiff and I doubted my ability to do so.*

*He re-banded my leg and helped me to his famous donkey. Two or three times on the way down he grinned at me and said: "That was a very nasty spot we have just passed. Jacko's snipers are wonderful shots. It doesn't do to loiter in such spots."*

*When you realise that he knew the extreme dangers to which he so constantly exposed himself in his self-imposed errands of mercy you can only marvel at the cheerful way in which he carried out his duties.*

*He brought me safely to the beach clearing station and when I thanked him, he smiled and said, "Glad to help you."*

Simpson had a real concern for his donkey. He acquired a Red Cross Brassard, which he fastened to the donkey's head.

In the middle of May 1915, the Turks continued to make desperate violent attempts to force the Australians from the ridges, particularly at Quinn's Post.

Turkish troops had been reinforced to approximately 30,000 men.

Early on the morning of May 19, Simpson, having filled his water bottles at the water-hole on the beach head, went to a cook-house for breakfast.

However, it was not ready.

He went on his way with his donkey up to the ridges beyond Shrapnel Valley.

He soon picked up a casualty, and was on his way down, when he was hit through the heart, by either shrapnel or by a bullet, at the exact location where General Bridges had been killed a few days earlier.

A friend, Andy Davidson, came across and found Simpson's body lying next to his wounded assistant and companion — the donkey.

Davidson and his men covered the body and placed it in a dugout beside the track.

Later that day Simpson's body was recovered and brought down to the beach area for burial at Hell's Spit, that evening.

A simple wooden cross was placed on his grave, with the name "John Simpson."

Colonel (later General Sir John) Monash wrote to Headquarters, New Zealand and Australian Division:

*I desire to bring under special notice, for favour of transmission to the proper authority, the case of Private Simpson, stated to belong to C Section of the 3rd Field Ambulance. This man has been working in this valley since 26th April, in collecting wounded, and carrying them to the dressing stations.*

*He had a small donkey which he used, to carry all cases unable to walk.*

*Private Simpson and his little beast earned the admiration of everyone at the upper end of the valley. They worked all day and night throughout the whole period since the landing, and the help rendered to the wounded was invaluable.*

*Simpson knew no fear and moved unconcernedly amid shrapnel and rifle fire, steadily carrying out his self-imposed task day by day, and he frequently earned the applause of the personnel for his many fearless rescues of wounded men from areas subject to rifle and shrapnel fire.*

*Simpson and his donkey\* were yesterday killed by a shrapnel shell, and inquiry then elicited that he belonged to none of the Army Medical Corps units with this brigade, but had become separated from his own unit, and had carried on his perilous work on his own initiative.*

*(\* The donkey was not killed.)*

How many lives Simpson saved is not known.

Simpson was never awarded any posthumous decoration, even though official reports of his extreme bravery and valour had been forwarded to the proper authorities. But it does seem, that because he was a non-combatant, his zeal, conduct and actions were not considered worthy or recognised as being conducive to any specific victory action in the face of the enemy.

## What happened to Simpson's donkey

There was a number of donkeys on the Dardenelles Peninsula, some being used by the Greek water carriers.

A few had been brought to Gallipoli by the ANZAC Forces to be used as carriers for the guns and ammunition.

It was the day after Simpson's death that Simpson's donkey wandered in at the Casualty Clearing Station located on the beach head, and was soon seconded by troops from one of the Indian Batteries, to be used as a water carrier.

However, it has now been claimed by two Gallipoli veterans, both AAMC members (C. J. Lambert of Newcastle, NSW and D. Braithwaite of Chatswood, NSW) that a few weeks after Simpson's death, the donkey plus one other were killed and then eaten, carried by Indian troops to supplement their bland, monotonous hard rations.

How ironical it was then, for this proven reliable sure-footed little beast with abnormally very large ears, and on whose back so many wounded men had once been carried, that its life would be thus terminated so that its carcass could be used to fill the bellies of men.

Researched from:

"The story of Anzac, Official History (1921)"  
C. E. W. Bean.

"Official history of the Australian Army Medical Services, 1914-18 — Vol 1 Gallipoli"  
A. G. Butler.

"A history of the Great War, 1914-18" Hart,  
Liddell.

The Australian War Memorial archives.

English newspaper reports.

The RAAMC Military Museum, Healesville,  
Victoria.

2nd Field Ambulance — RAAMC History  
Precis (1968.)

*/more ad.*

**Alex Kaplan & Son (Pty) Ltd**

**P.O. BOX 132,  
GERMISTON, 1400  
SOUTH AFRICA**

**LIST OF MEDALS FOR SALE  
POSTED FREE  
BY AIR MAIL ON REQUEST**

**We Want to buy  
or  
trade  
Any**

**British Campaign Medals,  
Especially those to South African  
Units.**



# BOOK REVIEWS

*by A. JACKSON & K. R. WHITE.*

**ATLAS OF NAVAL WARFARE:** Helmut Pemsel. Published by Arms and Armour Press. Australian distributor Thomas C. Lothian Pty. Ltd., 4-12 Tattersalls Lane, Melbourne. Australian price \$32.75.

This large format book was first published in Germany in 1975 and the English language edition was produced in 1977.

The subject matter covers the wars of the ancient Greeks starting in 492 BC right through to the Arab-Israeli conflict of October 1973.

The reader is presented with a comprehensive index which enables him to readily locate a particular battle with ease. The work is set out in chronological order and more than 250 maps are provided to show the course of the battles.

A series of line drawings illustrate the evolution of the warship from the galley to nuclear submarines.

Of immense value to those interested in the history of war at sea.

**BRITISH AND AMERICAN INFANTRY WEAPONS OF WORLD WAR II:** A. J. Barker. Published by Arms and Armour Press. Australian Agent Thomas C. Lothian Pty. Ltd., 4-12 Tattersalls Lane, Melbourne. Australian price \$5.25.

This well illustrated book will serve as a basic reference for the bulk of collectors who are not specialists in this field.

It covers the entire field of weapons used by the British and US infantrymen, ranging from pistols to anti-tank guns and flame-throwers, as well as the ammunition used in the various weapons.

Basic data is supplied on each weapon, together with details of its development. In some respects this is rather limited, especially in the case of grenades where one page of text and one illustration is the total cover given.

Australian developments are not included. Despite its limitations, it is a well-produced book which will be of use to collectors and wargamers.

**THE GERMAN ARMY 1933—1945:** Matthew Cooper. Published by McDonald and Janes. Australian price \$29.95.

This detailed 598-page book is well illustrated and follows the German Army from 1933 to 1945, giving the political destiny, through the battle of ideas and then to the rise and eventual fall from power. It has an appendix on the organisation of the Army in September, 1939.

The ideal book for those studying the Germany Army and its battles.

**DESERT RATS AT WAR, 2 — EUROPE:** George Forty. Australian agents, Cambridge University Press Pty Ltd., 296 Beaconsfield Parade, Middle Park, Vic. 3206. Australian price — \$15.60.

This is the second and final volume of the history of Seventh Armoured Division (see "Sabretache" Vol. XVII No. 3) continuing the history from the invasion of Italy through to the final victory in Europe in May 1945.

Again the text is well supported by hundreds of photographs with a wide coverage of personalities, equipment and weapons. Maps are used to show the Division's part in the invasion of Italy, France and various major actions in which it fought.

The actual production of the book is of the same high standard featured in the first volume and along with the subject matter represents real value for money.

Due to the large number of photos, the book is a valuable reference for modellers and those interested in AFV's and soft-skinned vehicles as well as those interested in the more general history of a famous Division at war.

**THE STANDARD CATALOGUE WAR MEDALS OF THE WORLD:** S. C. Perkins. Australian agent, P. F. Varney, PO Box 136, Bentley, WA 6102. Australian price \$7.00 post paid.

This is a small book of 139 pages, packed with information on all British and Commonwealth Service medals, decorations and other awards plus a similar coverage of U.S. awards. However, this is the limit of coverage of medals of the world.

The text is supplemented by values in Sterling and also by a fine set of line drawings, numbering well over a hundred. The text describes the medal, numbers issued in many cases, provides information on variations, and details of bars issued. One omission noted was the South Vietnamese clasp for the General Service Medal 1962.

All told, a useful reference book for the medal collector.

**LUFTWAFFE HANDBOOK 1939-45:** Alfred Price. Published by Ian Allan Ltd. Australian price \$10.35.

## THE WOODFORD BOOKSHOP

**Out-of-print and secondhand books  
specialising in Military, Naval and Aviation**

Collections and single items purchased

Quarterly Military Book Catalogues issued.  
Sample copy sent airmail on request

**33 VICTORIA ROAD, SOUTH WOODFORD,  
LONDON E18 1LJ ENGLAND**

**Telephone: 01-989-4536** *Delete Not paid*

The author spent 16 years researching his subject before producing what must be considered a basic reference manual on the Luftwaffe.

Although of only 111 pages, the book covers all aspects of the Luftwaffe from organisation of high command through to uniforms and equipment.

The book is set out in a logical manner and is well illustrated with all manner of equipment from aircraft, radar, flakposts through to uniform detail. It also includes brief biographies of senior commanders.

Of particular value to modellers are the details of aircraft markings with explanations.

**COMMANDOS & RANGERS OF WORLD WAR 11:** James Ladd. Published by McDonald and Janes. Australian price \$17.95.

An interesting book dealing with commandos and rangers during World War 11, with histories and unit battles.

This book also deals with the organisation, weapons, transport, communications and training a commando depot.

A very detailed book for the enthusiast.

*Delete Not paid.*

# **DONALD HALL**

**ORDERS, DECORATIONS and WAR MEDALS  
BOUGHT and SOLD**

*PERIODIC CATALOGUES ISSUED  
SENT BY AIR-MAIL FREE OF CHARGE*

Write to:

**DONALD HALL  
Victoria Corner, 35 Victoria Road,  
LONDON E18-1LJ  
ENGLAND**

THIS is the first in a series of articles on tanks and armoured fighting vehicles which helped shape our military history.

Each of the vehicles featured is now located at the Royal Australian Armoured Corps Tank Museum, Puckapunyal Army Camp, Victoria.

Vehicle details and photographs are from the Tank Museum's magazine.

# TANKS OF THE PAST

## VICKERS MEDIUM TANK MK 11A (Australian)

THE Vickers Medium tank, originally designated a Light Tank was virtually the only tank in service with the Royal Tank Corps until the mid-thirties.

Production of the Vickers Medium Tank began in 1923 and amounted to some 160 Marks I and II.

The Mark I had a box-bogie type spring suspension which gave increased speed but caused a short track life and much effort was devoted to solving this problem.

The air-cooled engine, though sound in principle, was somewhat inaccessible and the large cooling fan absorbed too much power. The engine was governed at 1800 revolutions per minute and had a high performance at low speeds.

For ease of starting, a hand magneto was fitted together with a half compression device. Clutch and brake steering was used, the clutches being of the dry plate type incorporated with epicyclic reduction gears.

A normal four-speed gear box was fitted which, with the high and low ratios on the epicyclic reduction gears gave 8 speeds in all.

Engagement of low ratio was by the

use of steering levers and was a hard slow action.

The Mark Ia and Ia\* were improved versions, the Ia\* being the first to mount a machine gun coaxially in the turret. The Mark II was fitted with skirting plates to protect the suspension with the result that the weight went up from 11 ¼ tons to 12 ½ tons.

Steering was improved by the use of Rackham clutches, whereby the application of the right or left steering brake-band activated the clutch on that output shaft. Epicyclics were retained for emergency bottom gear.

Although the general layout can be criticised, they were the first tanks used by the British Army to have all round traverse and geared elevation for the gun. They were included in the Experimental Armoured Force of 1928 and formed the basis of the 1st Tank Brigade in the mid 1930's.

This tank was the result of infantry insistence on the use of machine guns to deal with enemy infantry. When first produced the 3-pr (47mm) gun was capable of defeating any contemporary tank, but by the decade prior to the



Second World War, it was completely inadequate for the tank-to-tank battles which were to follow in Europe and elsewhere.

In 1928 the Australian Army received four Vickers Medium Tanks which were taken to the Small Arms School at Randwick, NSW.

A Militia unit, the First Australian Tank Section, was raised and equipped with the tanks in 1929. A second section was raised later.

Later, this tank section formed the basis of the Australian Tank Corps, which during World War 2, formed the Australian Armoured Divisions (1, 2 and 3), and several independent Tank/Armoured Brigades.

It is interesting to note that the Australian Tank Corps badge had the motto, "PARATUS," which is now the motto of the First Armoured Regiment in Puckapunyal.

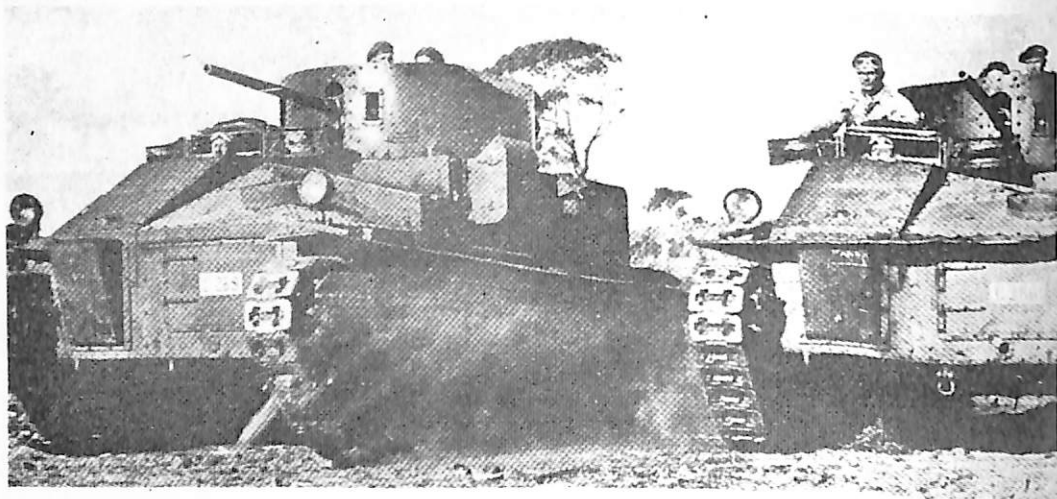

#### Specifications:

Power Plant:	Armstrong Siddeley V8 air cooled engine giving 90 bhp.
Speed:	18 mph.
Armament:	3 pounder (47mm.) Quick Firing Gun. 4 Hotchkiss machine guns in turret. 2 Vickers machine guns in hull.
Crew:	5. Commander, Gunner, Loader/Hull Gunner, Hull Gunner, Driver.
Weight:	12.5 tons.
Armour:	8 mm.
Designed and built:	Vickers-Armstrong Ltd. Elswick. Issued for service 1923.

The tank pictured may well be the only survivor of the very small batch of about 12 built in 1928, of which four were for Australia and the remainder for Russia.

*ACT Branch to Pay.*

**LATEST PUBLICATIONS —  
LIMITED EDITIONS**

**“Australia’s First Naval Fight”**

The story of the H.M.A.S. Sydney — Emden action. Including a Roll of Honour of killed and wounded, a list of Officers and crew together with addresses of next of kin.

**A MUST FOR ALL MEMBERS**

**Available from Federal Secretary**

**Price \$5.00**

**“NOMINAL ROLL OF OVERSEAS  
CONTINGENTS FOR THE  
CORONATION, 1911”**

Rolls of Naval and Military contingents from Canada, Australia, Newfoundland, New Zealand, Union of S. Africa, Rhodesia, Malta, Bermuda, Ceylon, Straits Settlements, Federated Malay States, Hong Kong, Barbados, British Guiana, British Honduras, Jamaica, Leeward Islands, Windward Islands and Royal Canadian Mounted Police.

**Available from Federal Secretary**

**Price \$5.00**

**Orders of 10 or more copies reduced by  
20 per cent**

*Set Bound to pay.*

## ITEMS AVAILABLE FROM FEDERAL SECRETARY

All profits from the sale of these items are used to further the efforts of the Society in providing additional publications at a minimum price for members, so buy and help the society to help you.

Publications Available	Price
Soudan Contingent, NSW 1885, R. Clark (2nd Edition).....	\$2.50
Medals to Australians, M. Downey .....	\$2.50
1976 Price Supplement .....	\$2.00
New Zealand Medal for HMCS Victoria, R. Clark.....	\$1.00
Australian Awards of the Kings South Africa Medal, R. Clark	\$2.50
Gallant and Distinguished Service Vietnam, I. L. Barnes ...	\$5.00
Australian Contingents to the China Field Force, D. Atkinson	\$5.50
Australian Service Long Arms, I. D. Skennerton.....	\$12.50
Australian Service Bayonets, I. D. Skennerton.....	\$11.50
List of Changes in British War Material, Vol 11 (1886-1900) I. D. Skennerton .....	\$12.50
Victorian Volunteer Long and Efficient Service Medal 1881-1901 .....	\$10.00
Morshead, J. Moore .....	\$6.00
Saga of a Sig, Ken Clift.....	\$5.50
Citizen General Staff C.D. Coulthard-Clark (soft) \$5.50 (hard)	\$10.00
Military Origins, Gordon.....	\$3.50
Whale Oil Guards, J. Kennedy .....	\$6.00
Kapyong Battalion, J. J. Atkinson .....	\$7.50
42 Infantry Battalion, S. E. Benson .....	\$5.00
Sir John Monash, A. J. Smithers .....	\$7.95
The Desert Hath Pearls, R. Hall.....	\$9.95
Volunteers at Heart, D. H. Johnson .....	\$11.00
As It Was, C. Dieppe .....	\$3.50
For Queen and Empire .....	\$4.50
Kimberley Flying — Tpr. Frank Perhan .....	\$2.00
Uniforms of Australian Colonies — Festberg/Videon .....	\$6.00
Australians in the Boer War — Wallace .....	\$11.95

Allow \$1 Postage for first book, plus 50¢ for each additional item.

Any surplus will be refunded.

---

# Snippets from World War 1

---

- **GREAT BRITAIN** declared war on Turkey on November 5, 1914.

On New Year's Day 1915, a train of ore trucks set out from Broken Hill, crowded with members of the Manchester Unity Order of Oddfellows off on their annual picnic.

A couple of miles out of town, two men with rifles, flying the Turkish flag from an ice-cream cart, opened fire on the train.

Four people were killed and many others, including children, were wounded, some badly.

Police, soldiers and rifle club members were summoned, but the two Turks took to the hills and were able to hold hundreds of armed men at bay for over an hour.

Finally one was killed and the other fatally wounded.

It was then discovered that the two gunmen were both well-known in Broken Hill.

They were Gool Mohammed, an ice-cream vendor from north-west India, and Mullah Abdullah, an Afghan butcher.

They had decided — apparently under the influence of drugs — to die fighting for Turkey and the Mohammedan religion.



- **NO GERMAN** spies were discovered in Australia during World War 1 but there were frequent outbreaks of spy hysteria.

Thousands of letters about suspicious happenings bedevilled the authorities.

A cricket club laid a concrete pitch and was accused of preparing a gun emplacement.

Flights of birds were reported as being waves of enemy aircraft. Basking whales off one seaside resort caused a flood of reports of enemy submarines being sighted in the area.

One Melbourne patriot reported sinister flashing lights in the Dandenongs. When investigated they proved to have come from a rabbit trapper who was inspecting his traps by hurricane lamp.

## CONTRIBUTION TO SABRETACHE

THE Editor of Sabretache is always seeking articles. Have YOU any interesting historical information that may be suitable?

As long as you can provide all the necessary facts, the Editor will, if necessary, rewrite the story. Black and white pictures and line drawings are also sought for publication.

For further information, contact:

The Editor,  
Sabretache,  
P.O. Box 30, Garran,  
A.C.T. 2605



*Delete Not found*

# CALOUNDRA MILITARY MUSEUM

CALOUNDRA ROAD  
(Next to Drive-In Theatre)

*Unique Display of . . . . .*

### ● MILITARY VEHICLES

● GUNS

● UNIFORMS

● RIFLES

● MEDALS

MUSEUM OPEN 7 DAYS A WEEK  
9 a.m. TO 5 p.m.

THE Victoria Cross awarded posthumously to Flight-Sergeant Rawdon Hume Middleton in 1942 has been presented to the Australian War Memorial.

The medal was bought with funds raised from a public appeal initiated by the Air Force Association.

It brings the memorial's collection of Victoria Crosses to 20, the largest collection in the world.

Ninety-six Australians have won Victoria Crosses since the first was awarded to Captain Neville Howse in 1900.



## **Flt-Sgt. R. H. Middleton V.C.**

FLT-SGT. Middleton, RAAF, was attached to 149 Squadron, RAF. His V.C. was for action on the night of 28-29 November, 1942, in a raid on Turin, Italy.

His citation reads:

Flight Sergeant Middleton was captain and first pilot of a Stirling aircraft detailed to attack the Fiat works at Turin one night in November, 1942.

Great difficulty was experienced in climbing to 12,000 feet to cross the Alps, which led to excessive consumption of

fuel. So dark was the night that the mountain peaks were almost invisible.

During the crossing Flight Sergeant Middleton had to decide whether to proceed or turn back, there being barely sufficient fuel for the return journey. Flares were sighted ahead and he continued the mission and even dived to

2,000 feet to identify the target despite the difficulty of regaining height.

Three flights were made over Turin at this low altitude before the target was identified. The aircraft was then subjected to fire from light anti-aircraft guns.

A large hole appeared in port main plane which made it difficult to maintain lateral control. A shell then burst in the cockpit, shattering the windscreen and wounding both pilots.

A piece of shell splinter tore into the side of Flight Sergeant Middleton's face, destroying his right eye and exposing the bone over the eye. He was probably wounded also in the body or legs.

The second pilot received wounds in the head and both legs which bled profusely. The wireless operator was also wounded in the leg.

Flight Sergeant Middleton became unconscious and the aircraft dived to 800 feet before control was regained by the second pilot, who took the aircraft up to 1,500 feet and released the bombs.

There was still some light flak, some very intense, and the aircraft was hit many times. The three gunners replied continuously until the rear turret was put out of action.

Flight Sergeant Middleton had now recovered consciousness and, when clear of the target, ordered the second pilot back to receive first aid. Before this was completed the latter insisted on returning to the cockpit, as the captain could see very little and could speak only with loss of blood and great pain.

Course was set for base and the crew now faced an Alpine crossing and homeward flight in the damaged aircraft with insufficient fuel.

The possibilities of abandoning the aircraft or landing in Northern France

were discussed but Flight Sergeant Middleton expressed the intention of trying to make the English coast, so that his crew could leave the aircraft by parachute.

Owing to his wounds and diminishing strength he knew that, by then, he would have little or no chance of saving himself.

After four hours, the French coast was reached and here the aircraft, flying at 6,000 feet, was once more engaged and hit by intense light anti-aircraft fire. Flight Sergeant Middleton was still at the controls and mustered sufficient strength to take evasive action.

After crossing the Channel there was only sufficient fuel for five minutes flying. Flight Sergeant Middleton ordered the crew to abandon the aircraft, while he flew parallel with the coast for a few miles, after which he intended to head out to sea.

Five of the crew left the aircraft safely while two remained to assist Flight Sergeant Middleton.

The aircraft crashed in the sea and the bodies of the front gunner and flight engineer were recovered the following day. Their gallant captain was apparently unable to leave the aircraft and his body has not been traced.

Flight Sergeant Middleton was determined to attack the target regardless of the consequences and not to allow his crew to fall into enemy hands. While all the crew displayed heroism of a high order, the urge to do so came from Flight Sergeant Middleton, whose fortitude and strength of will made possible the completion of the mission.

His devotion to duty in the face of overwhelming odds is unsurpassed in the annals of the Royal Air Force. (London Gazette. 15th January 1943.)



# OBITUARY

## MAJOR REX CLARK

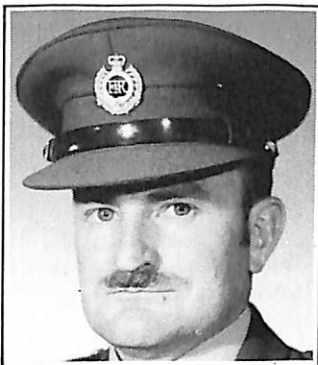

Rex Clark died at his home, in Canberra, on October 19th, 1978, leaving a widow, Cathy and a daughter, Lisette, to whom all members extend their deepest sympathy.

Rex was a close personal friend to myself and many other members of the Society, and his going will leave a gap in our lives which will never be filled.

He was a man who created a strong impression on all with whom he came in contact and with a seemingly in-exhaustable drive which enabled him to carry to fruition the various projects he undertook, in an endeavour to record many facets of Australia's proud military heritage.

His many published works are well known to all members, but perhaps not so well known as his encouragement of other authors in their efforts, giving freely the results of his own researches to ensure the success of their work.

His many articles in Sabretache fulfilled his own aim, and indeed that of the Society, to record in detail, deeds of gallantry mentioned briefly, if at all, in the official histories.

Also not generally known were his efforts to ensure publication of Sabretache, giving many hours of assistance to our Editors and, on occasions, financial support, so that members could receive Sabretache regularly.

He was human and like us all, had his faults. However, let us remember him for his many efforts to help us fulfill the aims of the Society and for those of us who were closer to him, for his friendship and assistance over the years.

— K. R. White.



THE Japanese Army used bicycles to race down the Malay Peninsula during WW2, and folding bikes were dropped with men of the British Army's Parachute Regiment. But the British Army had discovered the bicycle as an aid to warfare 40 years earlier, before the turn of the century.....

## To battle on bikes

*by J. R. WILLIAMS*

THE 1st Volunteer Battalion, the Worcestershire Regiment, traced its descent to the Rifle Volunteer Corps raised in the county of Worcester in 1859-60 in response to fears of possible French invasion.

The senior company of the Battalion

was raised at Woverley by Capt. F. W. Knight in 1859. In 1861 the Independent Rifle Corps was organised into the 1st and 2nd Administration Bns., Worcestershire Rifle Volunteers, the 1st recruiting in the north of the county and the 2nd in the south.

These battalions became the 1st and 2nd Worcestershire Rifle Volunteer Corps in 1880 and the 1st and 2nd Vol. Bns. of the Worcestershire Regt. in 1881.

With the formation of the Territorial Force in 1908, the 1st Vol. Bn. became the 7th (T.F.) and the 2nd Vol. Bn., the 8th (T.F.) Bns. of the Worcestershire Regt.

The photographs show cyclists of the 1st Vol. Bn. at the turn of the century.

Cyclist sections began to be introduced into British military formations in the 1880's and were intended for patrol and reconnaissance work.

The earliest mention of cyclists with the 1st Vol. Bn., is five cyclists of I (Stourbridge) Company, in 1894.

This had risen to ten by 1898.

The ground colour of the uniforms for both volunteer battalions was black, officially described as rifle green, with pea green piping above the cuffs and down the outer seams of the leg wear.

Cyclists did not wear the full dress head-dress, which at the period in question was the rifle busby for the 1st Vol. Bn.

In its stead they wore the undress head-dress of the day. In two of the photographs all wear the two buttoned cap, field service as introduced into the regular army in 1895-6.

The white metal cap badge had exactly the same design and size as the collar badge.

The frocks had five black, composition buttons down the front, one on each shoulder strap and one on each hip pocket, all bearing a stringed bugle horn.

The flapped patch pockets on the hips were characteristic of the frocks

worn by cyclist sections of many units.

Sergeants had a slanting slit pocket on the left breast, just below the third button from the top.

Black braid ran up the front and around the top of the collar and each cuff had a 'V' of similar braid.

A narrow line of pea green edged the top of the 'V' and was formed into a trefoil knot at the apex.

A narrow line of black braid edged the bottom of the 'V'.

The black rank chevrons were edged in silver.

In the picture of Sergeant Slater he has a small white metal cycle over his stripes, a silver embroidered volunteer proficiency star on the right forearm and silver embroidered crossed rifles on the left forearm.

Sergeant Slater sports a leather strap from which hangs a whistle, attached to his right shoulder strap button.

The picture of the soldiers around the tent have five cartridge tubes on each breast of the frock.

On the shoulder straps was embroidered a "1" over "V" within the curved title "WORCESTERSHIRE."

The white metal collar badge comprised a rayed elongated eight-pointed star with the Garter enclosing the lion of the Royal Crest in the centre, and a scroll with the motto "FIRM" below the Garter.

Black leather cartridge bandoliers are worn, passing under the left shoulder strap. The black leather waistbelts have the normal rifle pattern white metal snake clasps.

The pea green piped knickerbockers were tucked into black socks worn with black spats.

The rifles are carried in leather

buckets affixed to the front forks of the bicycle.

In the picture of the line of cyclists, the whole section are wearing the buff slouch hat, generally turned up on the left and made popular by colonial forces during the last Boer War.

**FOOTNOTE:**

•An excellent article on military cycling of the period is "Bicycles in the Anglo-Boer War of 1899-1902" by D. R. Maree in 'Military History Journal,' Vol. 4, No.1, June 1977, pub. by the South African National Museum of Military History.



Sgt. Slater.



A group of cyclists with their distinctive uniform.

---

**DID you know that the Army was involved in the capture of Ned Kelly?**

According to the special edition of "The Herald," Melbourne, June 28, 1880, the Artillery was called in to assist in Kelly's capture. It recorded that:

"Another special train was despatched for the scene of operations at a quarter past two. It conveyed twelve of the Garrison Artillery under command of Captain Anderson, and also a heavy piece of artillery, with which it is intended to blow down Jone's hotel, if the outlaw will not surrender."

*Where did this come from  
& who paid.*

# WEAPONS FOR SALE

AVAILABLE FROM: **Mr W. Keene, 16 Burnett St, Kaleen  
ACT 2617 — Phone (Bus) (062) 83-2617**

1. Swedish AG42B - semi auto rifle - Cal 6.5mm excellent condition. Matching numbers with tool/spares kit ..... **\$120.00**
2. German Commission 88 rifle. Cal 8mm Mauser, Amberg 1893. Excellent ..... **\$100.00**
3. Spanish Mod 43 (Mauser 98) rifle, cal 8mm. LA Coruna 1948 with bayonet — excellent condition ..... **\$85.00**
4. Spanish Mod 43 Rifle. Cal 8mm, mint condition. All matching No.2 Air Force model ..... **\$100.00**
5. Martini Medford Mk1\* Cavalry Carbine. Cal .303, with original Metford barrel and cleaning rod, ex cond. Has most of original finish. Rare item in this condition ..... **\$300.00**
6. Polish Mod 29 (Mauser 98) Rifle. 8mm cal excell condition ... **\$120.00**
7. Siamese Mauser 98. Cal 8.52 MMR. Excell cond with 4 Kynoch cases ..... **\$130.00**
8. Persian Mauser 98. Cal 8mm. Good condition, unusual variant **\$90.00**
9. Argentinian Mod 1909 cavalry carbine, cal 7.65mm. Very good condition ..... **\$100.00**

## Ammunition for Sale ★ Collectors or Shooters

- 7.65mm - Argentine/Belgium Mauser ..... **\$20 per 100**  
7.65mm French Rifle ..... **\$20 per 100**  
7.35mm Italian Rifle (18 rds per box, Inclips) ..... **\$3.60 per box**  
6.5mm Dutch Rifle (No clips) ..... **\$20 per 100**

### WANTED!

*Italian Mannlicher Carcano Rifle or Carbine  
Model 1938 7.35mm Cal only  
Will swap or buy*

CONTACT:

**Mr W. Keene,  
16 Burnett St,  
KALEEN ACT 2617  
Phone Bus (062) 83.2617**



## TREASURER'S REPORT FOR YEAR ENDED 30 JUNE, 1978.

ATTACHED is the audited financial statement for the year ended 30 June, 1978.

Although the accounts disclose a credit balance of \$713.55 this amount will be expended in the production of the next issue of "Sabretache" as will be seen from the Income and Expenditure Account. The annual costs associated with the publication and distribution of "Sabretache" amount to approximately \$4500 and are increasing.

I will present the incoming Federal Council members with a financial budget so that financial control may be exercised over these costs.

The financial viability of the Federal Council has been greatly assisted by the generous donations received from members.

In expressing the Council's gratitude to the donors, I would like to take this opportunity to advise members that donations are always appreciated.

In conclusion, may I remind members, particularly overseas members, that the annual subscription is \$A15.

Overseas airmail delivery of "Sabretache" is available for an additional \$A10.

As an Australian bank charge of \$A1 is now payable on overseas cheques, payments in Australian currency by overseas members and advertisers would be appreciated.

J.M. KENNEDY, JP, AASA, Honorary Treasurer, 1 July, 1978

---

### CASH BOOK SUMMARY FOR YEAR ENDED 30th JUNE, 1978

	\$
Balance brought forward from last year	14.67
Add amounts credited	6917.24
	6931.91
Less amounts debited	6218.36
Balance carried forward 30th June, 1978	713.55

#### BANK RECONCILIATION AS AT 30 JUNE, 1978

Balance as per bank statement 30th June, 1978	713.55
---	--------

(J. M. Kennedy JP. AASA)  
Honorary Treasurer.  
1 July, 1978

I have examined the financial records of the Military Historical Society of Australia and in my opinion the above statements are a true record of the financial transactions of the Society.

(E. Olsen)  
(Treasurer, The Hound Club of the ACT)  
Honorary Auditor  
26th Oct. 1978



# Australian War Memorial

## RESEARCH GRANTS FOR 1979

THE Australian War Memorial Board of Trustees has announced grants totalling \$16,914 for research in the field of military history.

It is the fourth series of annual grants awarded by the Trustees.

A total of \$14,314 has been awarded for 11 new projects, and the remainder has been allocated to projects already underway.

The Director of the Memorial, Mr Noel Flanagan, said today it was pleasing to note the overall improvement in the standard of applications for grants.

He said it also was pleasing to see increasing usage of the Memorial's vast historical resources. The grants for 1979 are:

- **M. W. Askey**, Sydney — History of the participation of Australian water transport units in the 1939-45 War.
- **Mrs. E. J. Herring**, Batlow, NSW — History of the Australian Army Medical Women's Service during the 1939-45 War.
- **Brigadier F. W. Speed**, Moggill, Queensland — Monash: An analysis of his professional excellence.
- **G. Verney**, University of Sydney — A biography of General Sir Brudenell White.
- **J. Eisenberg**, Stanmore, NSW and **Miss J. Wilton**, University of Sydney — Biography of General Sir John Wilton.
- **Mrs J. Bauer**, Nightcliffe, Northern Territory — Army Farms in North Australia 1940-44.
- **J. G. Grey**, Australian National University — Account of the role of Australian soldiers in the Intervention Forces during the Russian Civil War.
- **Dr. B. Clerehan**, University of Melbourne — Book length account of the battle of Milne Bay in perspective.
- **M. L. Hadlow**, Newcastle, NSW — Daily life behind allied battle lines in the Middle East and North Africa 1939-45.
- **Mrs L. Olive**, Sydney — Women in Khaki: A history of the Australian Women's Army Service 1941-47.
- **Lt. Col. S. N. Gower**, Australian National University — Field guns used by the Royal Regiment of Australian Artillery since 1854.

Carry-over grants:

- **Dr. M. M. McKernan**, University of NSW — The Australian People and the Great War: A social history.
- **Dr. L. L. Robson**, University of Melbourne — Britain, the A.I.F. and Australia 1914-19: perceptions and inter-relations.
- **Rev. F. Glen**, Invercargill, New Zealand — Australian involvement in the Maori Wars.

*Member add. - 50 words*

## WANTED TO COMPLETE 1930-42 INFANTRY BADGE SET

- HAT** — 6th (City) Brass, 15th (Brass), 27 (SA Regt) in white metal, 27 (SA Scottish) Bronze, 34th (1st type) 41st (any finish.)
- COLLARS** — 16th, 23rd, 27 (SA Regt, white metal) 27 (Scottish) 34th (1st type) 54 and 55 Bns (any finish)
- ALSO** — Any Buttons of Australian Colonial Forces - all sizes and finishes.

Will purchase or exchange

WRITE TO:

**Ken White,**

**PO Box 67**

**LYNEHAM ACT 2602**

*Member add? - 50 words*

## WANTED

- Militia Infantry tunic of the 1930's. Khaki with green or scarlet facings.
- Militia Light Horse tunic of the 1930's. Khaki with maroon facings.

## BUY OR TRADE

CONTACT

**P. NEWTON  
3 TOMBONDAN CRES.  
FERNY HILLS. Q. 4055**

ACT Grand to pay.

# AUSTRALIAN WAR MEMORIAL PUBLICATIONS

At 20% Discount to Society Members

These Australian War Memorial publications may only be purchased from the Secretary at a 20% discount on prices shown. Outstanding value which members should make use of. No limit on the number of copies a member may purchase. Postage must be added. Within Australia (per volume): N.S.W. \$1.20; Vic & Qld \$1.50; S.A., N.T. & Tas \$2.00; W.A. \$2.30 Overseas: \$3.50 (Any overpayment will be refunded).

## OFFICIAL HISTORY — AUSTRALIA IN THE WAR OF 1914-18 (12 volumes)

The following volume is still available:

Vol VI The A.I.F. In France, 1918, C. E. W. Bean ..... \$2.10

## OFFICIAL HISTORY — AUSTRALIA IN THE WAR OF 1939-45 (22 Vols)

The following 21 volumes have been published

Series 1 (Army)	To Benghazi, Gavin Long .....	\$2.50
	Greece, Crete and Syria, Gavin Long .....	\$3.00
	Tobruk and El Alamein, Barton Maughan .....	\$4.00
	The Japanese Thrust, Lionel Wigmore .....	\$4.00
	South-West Pacific Area — 1st Year, Dudley McCarthy .....	\$3.00
	The New Guinea Offensives, David Dexter .....	\$4.00
	The Final Campaigns, Gavin Long .....	\$3.50
Series 2 Navy	Royal Australian Navy, 1942-45, G. Hermon Gill .....	\$4.00
Series 3 (Air)	Royal Australian Air Force, 1939-42, Douglas Gillison .....	\$4.00
	Air War Against Japan, 1943-45, George Odgers .....	\$3.50
	Air War Against Germany & Italy, 1939-43. John Herington ..	\$3.00
	Air Power Over Europe, 1944-45, John Herington .....	\$3.50
Series 4 (Civil)	The Government and the People, 1939-41, Paul Hasluck .....	\$3.00
	War Economy, 1939-42, S. J. Butlin .....	\$2.50
Series 5 (Medical)	Clinical Problems of War, Allen S. Walker .....	\$3.50
	Middle East and Far East, Allen S. Walker .....	\$3.50
	The Island Campaigns, Allen S. Walker .....	\$3.50
	Medical Services of the RAN & RAAF, Allen S. Walker .....	\$3.50

Anzac to Amiens, C. E. W. Bean	
A concise history of the 1914-18 War .....	\$3.00
The Six Years War, Gavin Long	
A concise history of the 1939-45 War .....	\$7.50
Pictorial History of Australia At War, 1939-45	
A five volume photographic record .....	\$23.00
Soldiers of the Queen — 12" long play record	
Music of the Boer War (Postage 80c) .....	\$4.00

They Dared Mightily, Ed. Lionel Wigmore in collaboration with  
Bruce Harding. The story of Australian VC and GC awards ..... \$4.20

Australia At Arms, Ed Norman Bartlett  
From the Maori Wars to World War 11 ..... \$2.50

With the Australian in Korea, Ed. Norman Bartlett  
A cover of the Korean War ..... \$2.50

The Shellal Mosaic, A. D. Trendell, Paperback, illustrated  
Description of the discovery, origin and design of this important relic ..... 60c

Other Banners, Ed. J. T. Laird  
An anthology of Australian prose and verse of the 1914-18 War ..... \$3.90

Military Aircraft of Australia, 1909-18, Keith Issacs  
The first of four volumes of a history of Australian military aviation since 1909 \$6.50

**Aircraft Mural Charts**

Chart 1: 1909-18; Chart 2: 1919-39; Chart 3: 1940-42; Chart 4: 1942-44; Chart 5:  
1945-53; Chart 6: 1954-71. Six charts of the Australian War Memorial aircraft mural  
by Harold Freedman ..... 35c each.  
*(Packaging and postage of one chart is 60c extra; two charts and up to six, posted  
together would cost an extra 80c)*

Hall of Memory — Paperback. Description with illustrations in colour ..... 60c

Australian War Memorial Paintings, Ronald Monson, Paperback, illustrated .60c

Portfolio of War Memorial Paintings, 9 reproductions ..... \$1.50

Postcards of War Memorial Paintings (6 in wallet) ..... 60c

Colour photographic postcards — War Memorial Scenes ..... 10c each

View Folders (2) — War Memorial Scenes in colour ..... 25c each

Colour Slides (35 mm) — War Memorial Scenes ..... 30c each

Blamey: Controversial Soldier, John Hetherington

A new and original biography of Field Marshal Sir Thomas Blamey, the only  
Australian to have reached the rank of field marshal ..... \$7.50

These Are Facts, R. Williams

The autobiography of Air Marshal Sir Richard Williams, the 'Father of the  
RAAF' ..... \$13.50

**WRITE TO FEDERAL SECRETARY**

.....

**ONE of the War Memorial voluntary guides, Mrs Penny Fisher, recently visited the National War Museum of Greece, and reported that there was little record of Australian involvement in the museum. As a result, a number of photographs and books have been donated to the Greek museum.**

# Portrait of a Sapper

by J. ROBERT WILLIAMS

FRANCIS Rawdon Chesney entered the Royal Military Academy, Woolwich, as a Gentleman Cadet on February 10, 1840.

After being awarded the Sword of Merit from the RMA for being the best cadet of his batch, he was commissioned into the Royal Engineers on January 11, 1843, as a Second Lieutenant.

From February 1843 to April 1844 he was engaged in Young Officer training in Fieldworks at the RE Establishment, Chatham, and was then at the RE Depot, Woolwich, awaiting posting instructions until September 1844.

October to November 1844 found him employed on engineer duties under the Commanding Royal Engineer, Plymouth District.

Chesney was on engineer duties in China (Hong Kong) with a detachment of the Royal Sappers and Miners (ii) from January 1845 to May 1847.

During this time he was promoted to Lieutenant on April 1, 1846.

In June 1847 he was on leave in England and from the same month until February 1850 he was on engineering duties in Ireland.

In March 1850 Chesney embarked for New Zealand with one Sergeant and 26 rank and file of the Royal Sappers and Miners.

They landed at Auckland on August 26, 1850, increasing the detachment there of the 6th Company Royal Sappers and Miners to half company strength of 41.

The detachment remained in New

Zealand until 1866 and saw service in the Maori War of 1860-66.

Chesney served in the campaign that led to the capture of the upper Waikato Valley in 1864 and was present at the assault and capture of Pukehinahina in the Bay of Plenty.

Chesney was promoted Captain on February 17, 1854, and Brevet Major on August 24, 1866.

He returned to Britain and was promoted to Lieutenant-Colonel on May 8, 1867.

He is recorded as District Commanding Royal Engineers at the Curragh Camp in 1870 and was made Brevet-Colonel on May 8, 1872.

On December 10, 1873, he was promoted to Colonel and is recorded as Commanding Royal Engineer Mauritius in 1875, which appointment he left in March 1876, and then retired from the service on April 1, 1876 with the honorary rank of Major-General.

He died on December 8, 1907 at the Hotel des Alpes, Vevey, Switzerland, aged 83.

In the photograph Chesney sports a scarlet jacket with a Garter blue velvet rounded collar, pointed cuffs and piping down the front edge, around the skirts, up the rear skirt slit and up the rear skirt seam.

The skirt corners were rounded.

The collar was edged all round with round gold cord.

For Field Officers the collar was also laced all round with gold lace within the gold cord.



★ ABOVE: Lt.-Col. F. R. Chesney, Royal Engineers, photographed in 1867 or 1868.  
*Photograph reproduced by gracious permission of H.M. The Queen.*



The gold lace on Chesney's collar completely obscures the ground colour and the embroidered crown indicates the rank of a Lieutenant-Colonel.

On the cuffs for Field Officers were chevrons of gold lace with narrow gold tracing braid and whorls above and below.

The eight gilt buttons down the front and the two at the rear waist had a "VR" cypher within a crowned garter bearing the title "ROYAL ENGINEERS."

The twisted gold shoulder cords on scarlet grounds, had embroidered silver flaming grenades and were secured by small gilt tunic buttons.

The crimson leather shoulder belt had a gold line near each outer edge and a central wavy gold line.

Its black leather binocular case had the Royal Arms with the mottoes "UBIQUE" and "QUO FAS ET GLORIA DUCUNT" all in gilt, on the lid.

The dark blue booted overalls had two-inch scarlet stripes and black leather around the bottoms and up the inside of the leg to above the knee.

They were secured under the instep by a leather strap and buckle.

Brass or steel swan necked spurs were screwed into the heels of the black Wellington boots.

The crimson leather sword belt and slings have two gold lines. The rectangular waistplate had a burnished gilt ground with a laurel wreath about a crowned garter bearing the title "ROYAL ENGINEERS" and enclosing a "VR" cypher, all in silver, mounted thereon.

The sword is the 1857 Royal Engineers Officers' Pattern, with a fish-

skin grip bound with brass wires, a gilt hilt and a brass Field Officers' scabbard.

Its swordknot comprised a gold cord and gold acorn.

On the table in the photograph stands Chesney's black busby. The busby was taken into wear by the Royal Engineers in 1856 and was replaced by the blue cloth helmet in 1878.

It had a Garter blue bag on the right and a white goats' hair plume, with a gilt ring slide, issuing from a socket behind a gilt flaming grenade badge on the left.

On the ball of the grenade were mounted the Royal Arms and the mottoes "UBIQUE" AND "QUO FAS ET GLORIA DUCUNT" in gilt. (iii).

The chinstrap was in black leather with a small gilt button.

Chesney was promoted Lt.-Col. on May 8, 1867, and Brevet-Colonel on May 8, 1872, so the photograph must have been taken between those dates.

"Hart's Annual Army List" records that Chesney received a medal for the 1860-66 Maori War. The medal was sanctioned on March 1, 1869. Thus as Chesney is not wearing the medal in the photograph, I have assumed that it was taken sometime between 1867 and 1869.

---

#### REFERENCES:

1. "Hart's Annual Army List."
2. Dress Regulations 1864.

I am also grateful to Lt.-Col J. E. South, the Librarian of the R.E. Corps Library, for providing additional biographical details.

#### FOOTNOTES:

- (i) Now the Royal School of Military Engineering.
- (ii) The Royal Engineers were a staff corps of officers and were not amalgamated with the Corps of Royal Sappers and Miners to form the Corps of Royal Engineers, until 1856.
- (iii) See illustration 843 of "Head-dress Badges of the British Army" by A. L. Kipling & H. L. King, London 1972.



# STOLEN MEDALS

MR P. Scascighini, of 41 Holley Road, Beverley Hills, NSW, has advised the Society that a group of medals in the name of "Barrow" has been stolen in Sydney.

The group comprises Military Medal, Efficiency Decoration plus Boer War and WW1 service medals.

The medals may be in two groups — father and son, but details are not known.

Any Society member who can offer any information is asked to contact their local police station or contact Mr Scascighini.

## AVAILABLE FROM ~~FEDERAL SECRETARY~~ *delete*

### Cloth Insignia

*50 each ad.*

Gold embroidered WO2 badge, pve 1939, each .....	\$1.50
Battalion shooting badge (3 types), khaki embroidered	\$1.00
Lewis Gunner badge, khaki embroidered .....	\$0.50
Packet of 10 different cloth items .....	\$1.00
BCOF formation sign .....	\$1.00

### Metal Badges — Hat

3 Cav Regt .....	\$2.50
RACT .....	\$1.50
RASR .....	\$1.50
WRAAC .....	\$1.50
Band Corps .....	\$1.50

**All proceeds to assist Society Funds.**

**Postage add 50¢ with each Order.**

YOU may have sung of the man who broke the bank of Monte Carlo, but have you heard of the Army sergeant who opened Australia's first bank account? What manner of man was Australia's first bank customer? A surprising amount has been unearthed about him.

# A £50 opener that made banking history

A few days before the Bank of New South Wales opened officially on April 8, 1817, it accepted a deposit of £50 (\$100) from Sgt Jeremiah Murphy, of the 46th Regiment, The South Devons.

Perhaps he had been posted for duty at some distant settlement and prevailed on the two-man bank staff of the new bank to take his money before he left.

In an age when few in the colony could read or write, and most signed with a cross, Sgt. Jeremiah Murphy signed the bank's signature register with a firm, clear hand.

His unit arrived in Sydney in 1814 to relieve the 73rd Regiment.

Until the 73rd vacated their barracks in George Street, Sydney — near the present Bank of New South Wales — the 46th Regiment camped on the racecourse, which is now Hyde Park.

Old Army records show that Jeremiah Murphy was born in County Cork, Ireland.

His official description was:

"Height, five feet six inches; round visage; swarthy complexion; grey eyes; brown hair."

Murphy was promoted sergeant in 1815 and his daily pay was 1/10d (about 18 cents.)



How could a man on such a low pay acquire £50.

Records at the Mitchell Library show he earned additions to his Army pay.

In July, 1816, Governor Macquarie entered in his diary that he drew a draft for £30/18/0½ (about \$61.80) for Sgt Murphy and his detachment employed for some time at Cox's River in the "New Discovered Country" across the Blue Mountains.

This was a Government donation for their 'extra harassing duty in collecting strayed cattle belonging to the Crown.'

He was also paid an additional £5 "as a gift for his vigilance and attention in the performance of his duty."

A soldier's life in the colony was more arduous and dangerous than is generally realised today.

The natives were raiding outlying areas, killing settlers and livestock.

In a proclamation in the "Sydney Gazette," the Governor said that to prevent "murders, robberies and depredations" by the natives, "settlers should drive them away by force of arms or, apply to a magistrate for aid from the nearest military station".

The Governor gave Sgt Murphy written instructions to deal with the hostile natives who plundered the Government depot at Cox's River.

He was ordered to take a corporal and 15 men and march by way of Parramatta, Penrith, Emu Ford, Springwood, Jamieson Valley, Blackheath and Cox's Pass to Cox's River, where he was to remain until further orders.

He was to keep open the route to Bathurst.

The party was to pick up a provision cart at Parramatta.

"Biscuits, sugar and salt for one month and a small allowance of spirits will be sent for the use of yourself and party and you will be furnished with the usual ration of fresh or salt meat at Cox's River," the order read.

Murphy was instructed to post a guard night and day on the depot at Cox's River and escort convoys and provisions to Bathurst.

"In case you should fall in with any hostile natives in the course of your march from Parramatta to Cox's River, you are to attack them, and take as many prisoners as you can, sending them back to Parramatta.

"You are, however, on all occasions of attacking the hostile natives, to save the lives of all their women and children if possible," the Governor said.

A year later Sgt. Murphy was paid £13/11/6 (27.15) and £5/14/- (\$11.40) for superintending the building of the Macquarie Light at South Head.

The light, an oil lamp, was said to be visible 24 miles — about 39km — at sea.

It replaced a fire lit nightly on an iron basket on a tripod.

The stone for the new lighthouse was cut from quarries nearby.

All the workmen, even the stonemasons, were convicts.

At the laying of the foundation stone at a breakfast ceremony, the Governor named the lighthouse "Macquarie Tower," and the assembled party drank success to it in a glass of cherry brandy.

It is also recorded at the Mitchell Library that soldiers who helped in harvesting could receive 5/- (50¢) a day "in money or wheat" and it is possible that Sgt. Murphy added to his income in this way.

His Regiment embarked for Madras in September 1817, but the Sergeant went to Van Diemen's Land with Capt. Wallis' company and did not rejoin his Regiment in India until later.

Before leaving Sydney he withdrew his money from the bank.

He died in Madras in 1820 at the age of 33, having willed his "effects and credits" to his wife, Mrs Honour Murphy, who was described in Army records as "with the Regiment."

If the bank had purposely chosen its first customer it could scarcely have done better.

On the evidence, he was a thrifty, capable man, who helped to develop Australia's inland and safeguard its shipping.

# The man behind Australia's first bank

MAJ.-GEN Lachlan Macquarie, to whose sponsorship the Bank of New South Wales owes its foundation as Australia's first bank, was a Scot of extra-ordinarily enlightened views.

As Governor from 1810 to 1821 of the infant colony of NSW, then primarily a penal settlement, he left an indelible mark in Australian history.

He was born at Ulva, in the Hebrides, on January 31, 1761, the younger son of Lachlan Macquarie, cousin of the sixteenth and last chieftain of 'Clan Macquarie.

Macquarie joined the Army as a volunteer in 1776 and after going to Canada with the 84th Regiment was commissioned.

He served throughout the American War of Independence.

Later he commanded the 86th Regiment in India in 1802 and on returning to England in 1803 he acted as AAG when Napoleon was threatening invasion.

In 1811, he was promoted brigadier-general and major-general in 1813.

On his arrival in Australia he found the colony "barely emerging from an infant imbecility."

By great personal exertion, Macquarie extended settlement far beyond the small settlement around Sydney and improved methods of agriculture.

He carried out a vigorous public works programme, and today some of the most graceful buildings in Australia stand as his monument.

He encouraged exploration of the unknown interior and laid foundations



for the great pastoral industry of the nation.

He promoted many cultural activities and developed education until one-fifth of the revenue was spent on schools.

He was the only Governor in history to appoint a "poet laureate," whose annual remuneration was the gift of two cows.

Macquarie opened the first school for aboriginal children.

But one of his notable works was his untiring efforts to give proper recognition to pardoned convicts.

He appointed emancipists to the bench and civil service — his chief architect was a former forger — and he entertained ex convicts at Government House.

---

## WAR MEMORIAL NOTES

---

- **THE** campaign medals of an officer who served in the Sudan, the Boer War, and World War 1 have been donated to the Australian War Memorial by Mrs D. Florance, of Bowral, NSW. The medals belonged to Captain W. Cope, Mrs Florance's great-uncle. Mrs Florance, who is 91, was told by the War Memorial that the medals are a very significant addition to the collection.
- **THE** Australian War Memorial has been approached by the Malaysian High Commission for assistance in the planning of a new military museum in Malaysia. A team from the Malaysian Department of Defence is expected to visit the Memorial on a study tour.
- **PROGRESSIVE** attendances at the Australian War Memorial in Canberra stood at 538,414 at the end of August. This is almost 28,000 more than at the same time last year. Some 61,129 people visited the Memorial during August.

### **HILLSIDE COINS & BADGES**

*Delete not paid*

P.O. BOX 658, CHRISTCHURCH  
NEW ZEALAND

*Dealers in Badges, Medals, Coins, Banknotes  
New Lists Issued Monthly*

Interesting Articles on New Zealand Badges  
in each issue

**WRITE FOR CURRENT LIST**

THE MILITARY HISTORICAL SOCIETY OF AUSTRALIA  
— FEDERAL COUNCIL -  
FINANCIAL STATEMENT FOR THE YEAR ENDED 30 JUNE, 1978.

**INCOME AND EXPENDITURE ACCOUNT FOR THE YEAR  
ENDED 30 JUNE 1978**

1976/7	Income	1977/8	1976/7	Expenditure	1977/8
1.58	Balance B/F	14.67	2710.00	Publication of Sabretache	4290.00
2616.83	Subscriptions				
	1975-6	10.00	145.24	Postage	219.36
	1976-7	195.00		Stationery	126.00
	1977-8	2369.33		Bank Charges	.10
	1978-79	977.73			
	1979-80	15.00			
	3567.06		111.26	Payment due to A.C.T. Branch	
	Less Capitation fees retained by branches	32.90			
		3534.16			
50.00	Donations	1442.00	14.67	Balance C/F	713.55
40.00	Advertising	151.24			
	Sales	41.60			
	Postage	40.94			
5.26	Bank Interest	15.40			
265.00	Subscriptions owed by ACT Branch				
2.50	Miscellaneous receipts				
	Special Project A/c				
	— Publication of				
	From Khaki to Blue				
	Advance against costs	1500.00			
	Sales to date	159.00			
	\$1550.00				
	Less publication costs to date	109.00			
2981.17		5349.01	2981.17		5349.01

# Some hat badges of the Australian Citizen Forces 1912-1918

*by D. P. Legg*



INFORMATION on badges worn during the 1912-18 period of the Australian Citizen Forces is still very incomplete.

The Bob Gray Collection illustrated in "Sabretache" Vol. XVI (1974) covered most of the known badges of this period but omitted the insignia of several infantry units which I have recently acquired.

These are the 37 Illawarra Infantry, the 60 Princes Hill Infantry, and the 64 City of Melbourne Infantry.

Mention was made of two of these badges (37, 60) in a later volume of "Sabretache," but neither was illustrated.

The badge of the 37 Infantry is in brass and has been used as the basis for the design of the first pattern 34 Battalion hat badge of the 1930 period illustrated by Adam Watson in the "Queenslander" badge series of 1931-32.

The 60 Princes Hill Infantry badge is in enamels, the upper and lower scrolls in blue and the central motto in white; the centre is voided.

This unit later changed its title in 1915 to Brunswick Carlton Infantry but continued to wear a similar badge, only the title on the lower scroll being altered.

The final badge to be discussed is the hat badge of the 64 City of Melbourne Infantry.

This rare badge is in gilt and enamel (central motto and lower scrolls in blue) and stamped on the back with "J & Co" as is the 60 Princes Hill badge.

The 64 Infantry badge design gave rise to the 6 Battalion City of Melbourne hat badge of the 1930 period (later the Royal Melbourne Regiment.)



# Prizewinners from Canberra's Show

LACK of suitable photographs made it impossible to include the three prizewinners of the A.C.T. Branch's recent display in the last issue of "Sabretache."

As announced then the prizewinners were:

1. Weapons and relics of the Peninsular War — Clem Sargent.
2. The desk of a minor Nazi official — Bill Palmer.
3. Military prints and illustrated books — Clem Sargent.

Here are the three prizewinning exhibits.

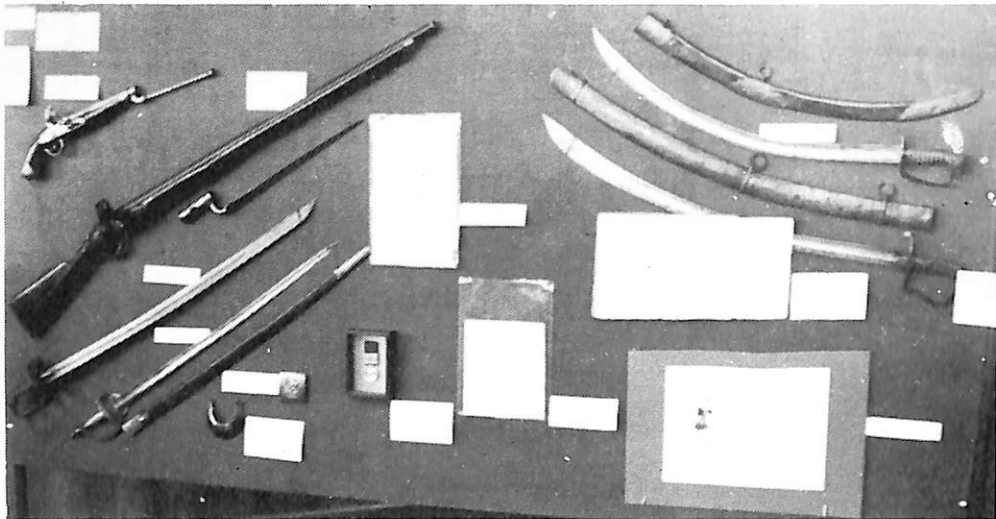

★ ABOVE: First Prizewinner — Clem Sargent's Peninsular War exhibit.

**THE Australian War Memorial's research grants for 1979 have been announced.**

Grants have been awarded for nine projects ranging from World War 1 through to World War 2, including "Account of the role of Australian soldiers in the Intervention Forces during the Russian Civil War" and "Monash — an analysis of his profession and excellence."

A total of \$7539 was awarded for new projects in 1979, with an additional \$5765 in 1980.

Another \$2600 has been granted in 1979 for three projects continuing from this year.



★ ABOVE: Prizewinner — Bill Palmer at the Nazi official's desk.



★ ABOVE: Third Prizewinner — Clem Sargent's display of books and prints.

MEN have marched into battle to the sounds of music... Music has graphically told its own tale of conflict.... Its notes salute the victors and mourn the vanquished....It is as much part of our military history as a soldier's blood, spilt on the battlefield.....

# All a matter of music

Sometimes a martial tune has turned the tide of battle.

In 1793, for instance the Bedfordshire Regiment was fighting the French at Famars in Holland.

Most of the English troops had not been in action before.

Every time they charged, they were driven back.

Then Col. Doyle galloped to the front. "What's that tune the French are playing?" he asked.

"It's 'Ca Ira,' Sir, the French Republican tune."

"Then we'll play it and beat them at their own damn tune," declared the Colonel.

And so they did, and the victory cost the British surprisingly few losses.

Ever since then, France's first revolutionary tune — about hanging aristocrats from lamp posts — has been the official March of the Regiment.

Some of the most famous marching songs belong to the United States.

"Yankee Doodle," originally an English tune, and "The Star Spangled Banner" are two of the best known.

Early in the American Civil War, two homesick recruits were heard singing a hymn near Boston. -

The tune was adapted by their Regiment and soldiers added words about one of their comrades, the famous

John Brown, who was a bitter opponent of the slave system.

On October 16, 1859, Brown and a small band of 22 men, seized the arsenal at Harpers Ferry.

In the morning they arrested townspeople as they appeared in the street and a number of slaves were set free.

Brown held the town for two days.

When the Militia arrived from Charleston, he was captured, tried for treason and hanged.

## Valour, their forte

Bravery in action is not exclusive to the fighting soldier.

Military musicians have shown that they are capable of heroism of the highest order.

Irrefutable testimony is the 14 Victoria Crosses that have been won by musicians.

During the Indian Mutiny of 1857-59, Bugler W. Sutton, of the 1st Battalion, 60th Rifles; Bugler R. Hawthorne, 52nd Regiment; Drummer M. Ryan, 1st Bengal Fusiliers; Drummer T. Flinn, 64th Regiment; and Trumpeter T. Monaghan, of the 2nd Dragoon Guards, were all awarded Victoria Crosses.

Drummer D. Stagpoole, of the 57th

Regiment, received both the Victoria Cross and the Distinguished Conduct Medal for bravery during the Maori Wars.

Bravery in Abyssinia and India resulted in awards to Drummer K. Magner, 33rd Regiment; and Piper G. Findlater, in 1868 and 1897.

During World War I six V. C.s were awarded to military musicians.

Of these men, Piper D. Laidlaw, 7th Battalion, King's Own Scottish Borderers is especially worthy of mention.

His citation read, in part:

“. . . On September 25th, 1915, Piper Daniel Laidlaw won the Victoria Cross in France in an assault upon German trenches near Loos and Hill 70.

“During the worst of the bombardment, when the attack was about to start, Piper Laidlaw, seeing that his company was somewhat shaken by the effects of gas, mounted the parapet and coolly marched up and down, playing his pipes.

“Inspired by ‘Blue Bonnets are over the Border’ the men dashed in to the attack.

“Piper Laidlaw continued to play until he was wounded.”

## A wedding band

Life was not all drumming, flogging and sweeping for the old-time drum majors.

History tells of Drum Major Thorp of the 88th Foot - Connaught Rangers - during the Peninsula Campaign.

During the Summer of 1809 the 88th were in quarters at Campo Mayor, and there, Jacintha Cherito, daughter of a wealthy Spaniard, Senor Jose Alfonso Cherito, Juiz de Fora of Campo Mayor, fell in love with Thorp.

She was a beautiful woman and the only daughter of Jose.

As soon as it was learned that the 88th were to leave Campo Mayor, Cherito made up her mind to elope with Thorp.

When her father discovered his daughter was missing - as was her jewellery - he rushed to the commanding officer and was given leave to search every man and all the carriages and baggage of the Regiment.

“Are you satisfied?” asked the Colonel.

“I am satisfied that my daughter is not with your Regiment, Sir,” replied JOse after his fruitless search, “yet I am anthing but satisfied as to her fate.”

The band played a quick march.

Thorp as drum major flourished his cane: The daughter of Joe Cherito, disguised as a cymbal-boy, with her face blackened and wearing a regimental jacket, banged the Turkish cymbals and the Regiment moved off.

They reached Monte Forte the same day and the couple were married.

## Now here's the drum

The drum is nearly as “old as Adam” and, of course, evolved from the Biblical timbrel.

In his “Popular Account of the Ancient Egyptians,” Sir J. Gardner Wilkinson writes that martial music, including the use of the drum, occupied an important place in Egyptian affairs about 1600 BC.

In the Chinese Army of the fifth century BC, the drum was used for giving signals during battle.

The credit for introducing the drum to Europe is generally accorded to the Crusaders who, having observed the fine

performance of the Saracens, brought the idea home.

Originally the drummers stood around the standard to assure the fighting men that the flag, although perhaps hidden from their view, in the din and dust of battle, was still flying.

The first occasion on which the drum was used on service on British soil appears to be at the battle of Halidon Hill — 1333.

Whatever exalted position a drum major may have had in the 16th and 17th centuries, by the latter part of the 18th century he seems to have dropped in status.

According to Thomas Simes — 1778 — his duties were: “..... to have with you your apparatus for punishing, as it is often found necessary to hold regimental courts-martial at the drum-head; and it should be an established rule, that a man who received 100 lashes, or more, should

pay you twopence; and if punished a second time for another offence, sixpence.

“No cat to have more than nine tails.

“You are to carry the letter to and bring them from the post office,” for which he ought, once a year, to get a small reward.

“You are every morning to see that the drummers sweep and clean the officers’ and men’s necessary houses,” and for which menial work Simes does not recommend any pay.

The drum major had not only to superintend the flogging of soldiers but had to instruct the drummers to flog with both hands.

Practice was given on sheepskin.

It was also the duty of the drum major to remove the stripes of NCOs who had been sentenced to reduction by a court-martial, but in later years this duty has fallen to the RSM.

---

**THE people of Villers Bretonneux have a special affinity for Australia. Two streets bear the names Rue de Melbourne and Rue de Victoria.**

★ ★ ★ ★

**AUSTRALIAN losses on the Western Front (France and Flanders) were greater than in the Gallipoli campaign. The dead numbered 46,012 which included 11,418 bodies never recovered.**

★ ★ ★ ★

**WHEN news reached Sydney in February 1885 that General Gordon had been murdered in Khartoum, an offer was made to the British Government to raise and despatch a force from NSW. On March 3, 1885, the troops marched from Victoria Barracks to Circular Quay where they were embarked on two transports. This was Australia’s first Regular Army commitment overseas. When the force disembarked at Suakin on the Red Sea on March 29, the fighting was almost over.**

★ ★ ★ ★

# Perth's Army Museum

---



THE attractive building, pictured above, is the home of the Army Museum of Western Australia, which was opened on December 18, 1977.

The Museum is housed in an old two-storey home near Perth which was acquired by the Army in the 1950's.

The home, named "Dilhorn," is believed to have been built around 1896-1899, and is of Victorian period architecture — admirably suitable for a museum.

"Dilhorn" originally was used as the Headquarters of the 13th Infantry Brigade (CMF), and later by Headquarters, 2nd Task Force, from 1960 to about 1975.

The Museum is controlled by a Management Board which consists of Army members as well as members of several other organisations.

The Military Historical Society of Australia has two members on the board.

# Early soldiers of note

DURING the period from 1788-1850 there were, in addition to the first company of Marines bought out by Governor Philip, no less than 21 British regiments at one time or another, stationed in NSW.

These regiments were sent out for a twofold purpose. Firstly to police and protect the Colony, and secondly as a toughening-up campaign to prepare the soldiers for Indian service.

Because of this system, NSW was fortunate to have some of the best regiments of the British Army, and their bands which travelled with them would have contained some of the best Army musicians.

In these early days of the Colony it is surprising to see just how much active music-making took place.

It was probably quite a shock to these musicians, who would have been used to playing for parades, regimental dinners and so forth, to find that they had to be prepared for anything that was likely to turn up.

These bands provided, in addition to their normal military duties, church music, music teachers, theatre players and light orchestral music for balls, dinners and so on

At certain times they banded together to become the Colony's first symphony orchestra.

The NSW Corps apparently had only drummers until 1806.

From August of that year there is mention of drummers and fifers.

It is quite reasonable to assume that it took some years for these soldiers to gain proficiency on their instruments.

In a letter from Provost-Marshal Gore to Viscount Castlereagh dated March 27, 1808, published in "Historical Records of NSW", mention is made of a march on Government House during the Rum Rebellion which was led by the fife drum playing the "British Grenadiers".

Around this time it was quite apparent that the social life of Sydney was getting well underway.

There are many references in the Colony's first Newspaper, the "Sydney Gazette", informing its readers of various entertainments.

The "Gazette" for April 14, 1810 reports: "On Monday evening last, a farewell ball and supper were given by the Captain and officers of *HMS Porpoise*.

"Many officers of the 73rd Regiment and 102nd Regiment were present and the atmosphere resounded with loyal airs from a large band."

---

**IN AN article on Army slang in the Melbourne "Argus" of November 15, 1941, G. Johnston wrote:**

**"Darwin appears to have the copyright of an interesting use of slang. The captain in charge of the Base Post Office, official Deputy Assistant Director of Posts, is given the Army abbreviation of DAD Posts. He is known everywhere simply as Dad, and his assistant, a lieutenant, is Mum. They are referred to everywhere by everybody as Dad and Mum."**



# Austro-Hungarian Monarchy

## Walking-out uniform of a Bandmaster of the Hungarian Infantry — 1910

*by J. ROBERT WILLIAMS*

THE subject of these notes is the walking out dress uniform of a bandmaster of an Imperial and Royal (i) Hungarian Infantry Regiment (ii). There were forty-seven Hungarian Infantry Regiments in 1914 and each was distinguished by the combination of its facing colour and the metal of its buttons (See the table below).

Facing colour	Regimental Number & Buttons		Facing colour	Regimental Number & Buttons	
	yellow	white		yellow	white
Black	26	38	Sea green	70	25
Red brown	68	78	Parrot green	46	50
Dark brown	12	83	Apple green	85	79
Dark red	52	53	Grass green	61	62
Amarant red	86	—	Steel green	48	60
Madder red	44	34	Pike grey	76	69
Cherry red	43	23	Ash grey	51	33
Carmine	96	82	Orange	64	63
Scarlett	37	39	Emperor yellow	2	31
Crab red	71	67	Sulphur yellow	16	101
Pale red	65	66	Light blue	72	29
Rose red	5	6	Sky blue	32	19

Walking out dress was exactly the same as full dress except that a kepi style black service cap replaced a feather plumed cocked hat. The cap (Fig 1) was in black waterproofed felt with a black patent leather peak and chinstrap.

Around the base of the cap was a red flecked silver cord. The rectangular chinstrap buckle was gilt and the plain chinstrap buttons were gilt or silver plated according to the regiment. At the front was a red flecked silver cord loop with a small gilt or silver button at the

base and at the top a cockade (Fig 2) comprising a silver cord boss with a silver "F J I" cypher on a red velvet ground in the centre.

The tunic (Figs 4 & 7) was dark blue with collar, cuffs and piping in the facing colour of the regiment. Its plain, slightly domed buttons were gilt or silver plated according to the regiment. Each side of the collar was a gold or silver embroidered lyre and sword (Fig 13), corresponding to the metal of the buttons. On the cuff was the "Bears' paw"

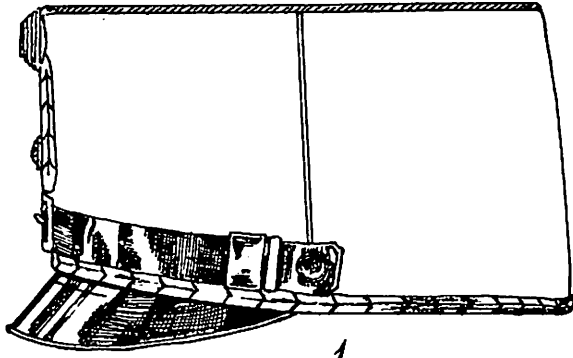

1.

JR Williams  
Stourbridge  
Dec. 1977.

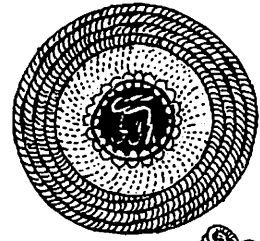

2.

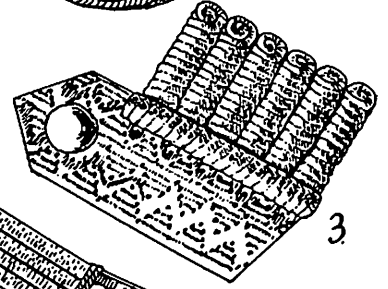

3.

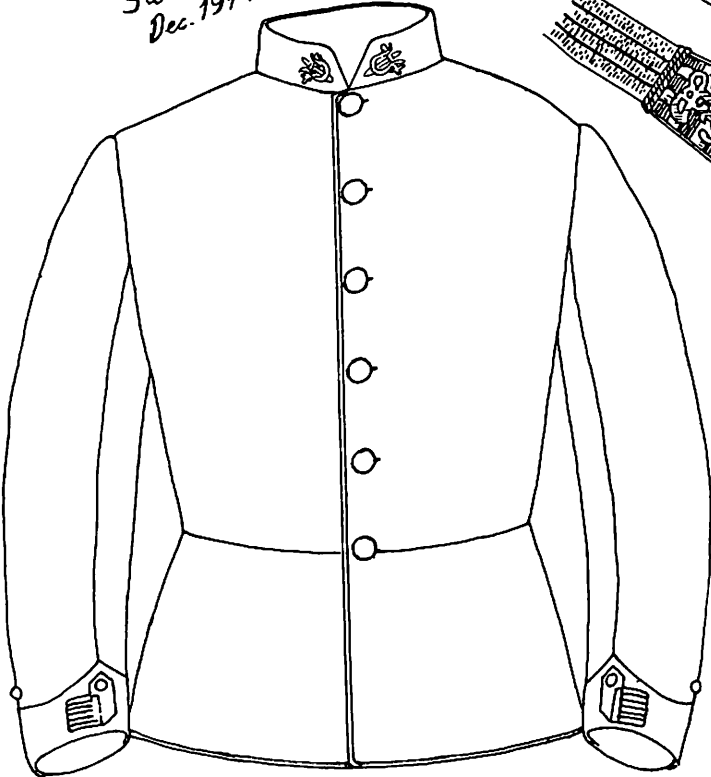

4.

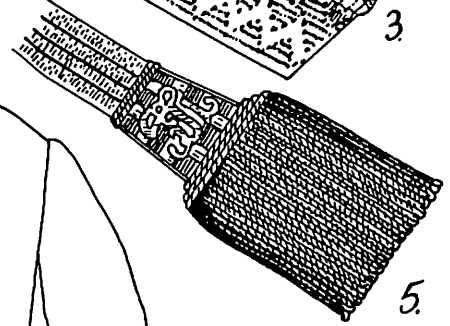

5.

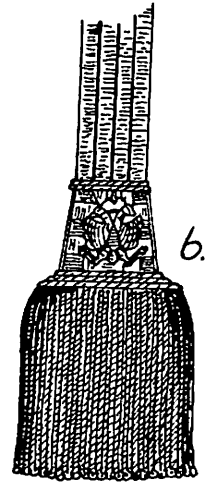

6.

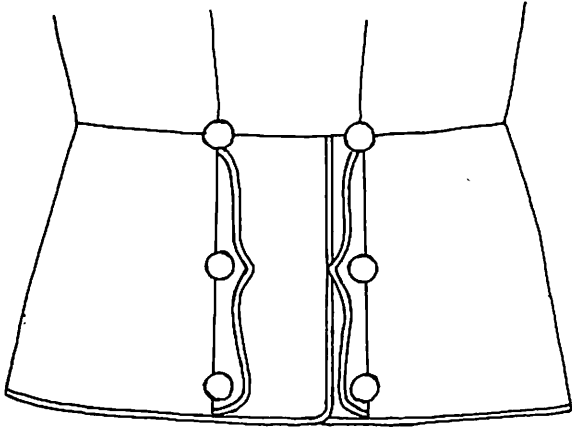

7

JRWilliams  
Dec. 1977.

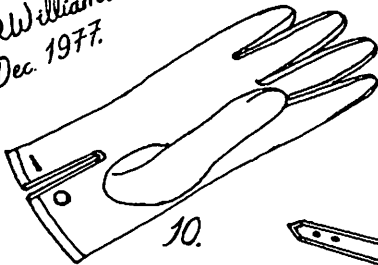

10.

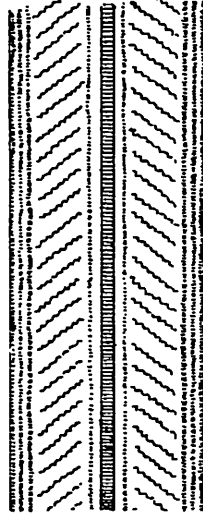

8.

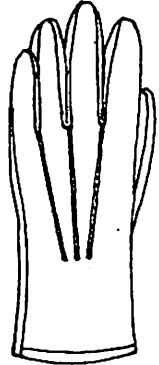

9.



11.

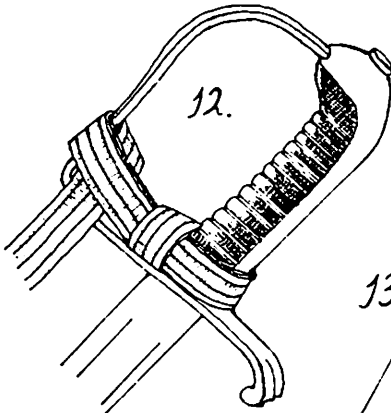
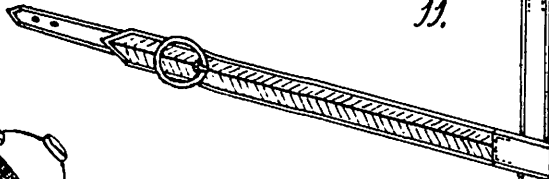

12.

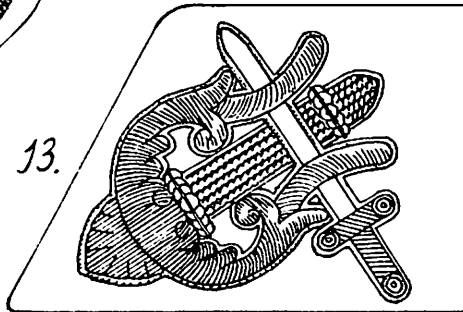

13.



lace of Hungarian infantry. It comprised a buttoned gold or silver strip of lace and seven gold or silver bullions (Fig 3). A white edged black stock was worn around the neck.

The gloves (Figs 9 & 10) were white and the pantaloons, worn over black half boots, were black with scarlet piping.

The swordbelt (Fig 11), worn under the tunic, was in red Morocco leather backed with natural colour leather. Its Morocco red slings were faced with 2.6 cms silver lace with a red silk central line (Fig 8.)

The 1861 pattern infantry officers' sabre with its plain steel stirrup hilt and fishskin grip bound with silver wires, had a steel scabbard. The swordknot (Figs 5 & 6), was silver.

It had three red silk stripes in the strap. On the outer side of the tassel head was worked an "F J I" cypher and on the other side a crowned double-headed eagle. The silver fringes enclosed red fringes.

**Source:**

"Adjustierungsvorschrift fuer das K.u.K.Heer," Vienna 1910/11.

**Footnote:**

- i. "Imperial and Royal" relates to the fact that Franz Joseph I was Emperor of Austria and Apostolic King of Hungary.
- ii. For uniform purposes the infantry of the Austro-Hungarian monarchy are divided into "German" and "Hungarian" regiments.  
The former recruited in the territories represented in the Imperial Parliament and the latter in the lands of the Crown of Hungary.
- iii. Pike grey pantaloons were worn in parade dress.

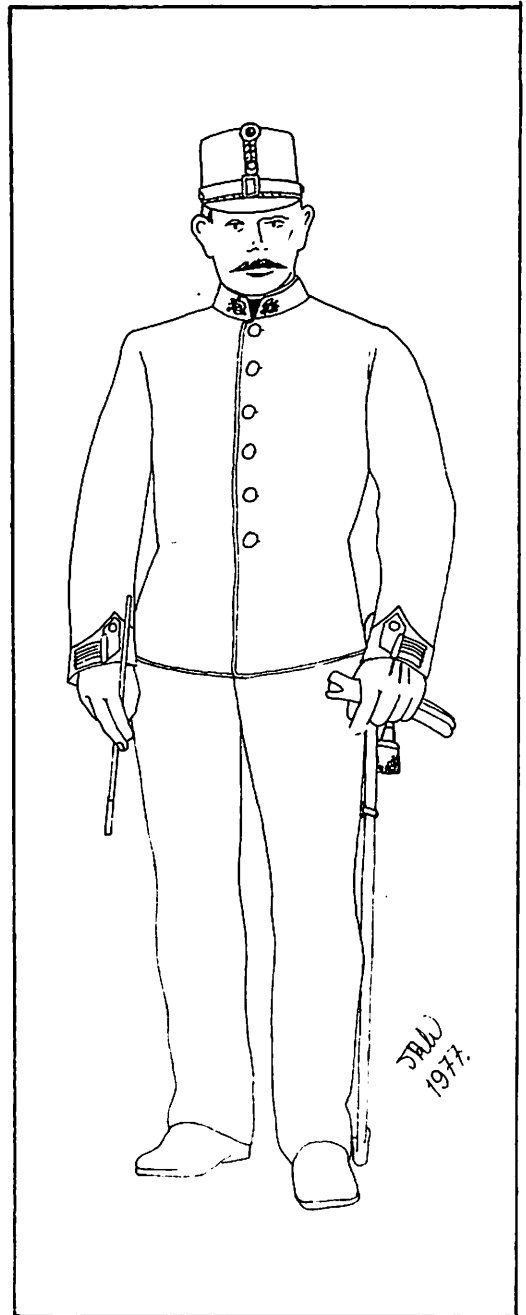

# FEDERAL COUNCIL

NOMINATIONS for positions on the Federal Council were considered at a Federal Council Meeting on 22 October 1978.

The following nominations were received:

Federal President:	Mr N. Foldi
Vice President:	Maj. H. J. Zwillenberg ED (RL)
Secretary:	Lt.-Col. T. C. Sargent (RL)
Treasurer:	Mr. J. M. Kennedy JP

These were the only nominations received and the above officers were declared elected to the positions.

The following notes have been prepared to acquaint Society members with their new executive:

## ● Federal President — Mr N. Foldi

Neville Foldi was born in Sydney in 1930. He enlisted in 30 Inf. Bn., NSW Scottish Regiment, in 1948 and served until 1959 when he transferred to the Reserve of Officers with the rank of Captain.

During 1958 he was seconded to 2 Ground Liaison Group as a Ground Liaison Officer.

A member of the ACT Branch of MHSA since 1964, he has served terms as Branch President, the most recent being in 1978.

His interests include model soldiers, particularly those manufactured by W. M. Brittain, British Military history from the Victorian era to the Great War and all aspects of Australian Military history.

He is a contributing author to the military section of the Australian Dictionary of Biography.

## ● Vice President — Maj. H. J. Zwillenberg ED (RL)

Maj. H. J. Zwillenberg, E.D.; M. A.; A.S.A.S.M; A.R.A.C.I; A.M. Aust. I.M.M; M.A.C.S.; F. Inst. Info. Sci.; has been an Army Reserve Officer and is now on the Retired List.

He has had a long association with the Society, first in South Australia and over the last ten years in Canberra.

Although primarily a technologist (metallurgy and librarianship) he has been involved over many years with the pre-federation military history of South Australia.

At present he holds the position of Director (Technology) in the National Library of Australia.

## ● Federal Secretary — Lt.-Col. T. C. Sargent (RL)

Lt.-Col. Clem Sargent, MIS, MAIC, has been a member of the Society since 1959 when he joined the Victorian Branch.

He was Inaugural President of the ACT Branch 1963/64, a foundation member of the WA Branch, and its President in 1970/71.

He returned to Canberra in 1975 on retirement after 29 years service in the Royal Australian Survey Corps and has taken an active interest in Society affairs since then, particularly as a member of the sub-committee responsible for the organisation of the 1978 ACT Branch display.

His personal interests are in the Peninsular War and the Peninsular Veteran in Australia.

He is currently employed as a civilian in the Department of Defence.

● **Treasurer — J. M. Kennedy, JP**

Martin Kennedy joined the Society in January, 1977, and has held the position of Hon. Federal Treasurer since elected in October, 1977.

He served with the RAAF in the Pacific Area during WW2 and subsequently as an Australian Government Public servant was employed in various departments including the Dept. of Navy and Army until invalided from the Service during 1978.

A Justice of the Peace and an Accountant, (Associate Member of the Australian Society of Accountants) Martin is also Vice President of the Hound Club of the ACT. Martin's Society interest is Australian Militaria Collecting.

---

**ONE of the War Memorial voluntary guides, Mrs Penny Fisher, recently visited the National War Museum of Greece, and reported that there was little record of Australian involvement in the museum.**

**As a result, a number of photographs and books have been donated to the Greek museum.**



**AUSTRALIANS may get the chance to see the Gallipoli campaign through Turkish eyes.**

**A 20-minute film of fighting at Gallipoli was presented to the Prime Minister, Mr Fraser, on behalf of the Australian Government, by the Turkish Minister for Social Security, Mr. Isguzar Hilmy.**

**The film, made by the Turks during the Gallipoli landings, will be loaned to the Australian War Memorial.**



**A COLLECTION of papers belonging to the distinguished Australian soldier, Brigadier John Field, DSO, has been donated to the War Memorial by his family. Brigadier Field commanded the 7th Australian Infantry Brigade in New Guinea and the Solomons in 1942-45, and the 2/12th Australian Infantry Battalion in West Africa and Tobruk in 1939-42.**

# Memories of Monash

Extracted from "John Monash" by Cecil Edwards.  
Published by the State Electricity Commission of Victoria.

THIS is how General Sir John Monash summed up the Australian soldier of World War I.

"...individually philosophic and stoical but in a mass he is sensitive to a degree; and he is intelligent enough to realise how he is used and unused..."

John Monash was in his 50th year "and looked every bit of it" when the war he had foreseen came in 1914.

He was immediately called up as deputy chief censor at Victoria Barracks, Melbourne.

That seemed an unlikely door to military fame for the colonel who had not seen a shot fired in anger in his 30 years of spare-time soldiering.

However, months later, he had downed his blue pencil to take a command in the field with the rank of brigadier-general.

Early reports described Monash as a tired and bewildered man but he erased that impression by his later conduct on Gallipoli and in France.

In July, 1916, Maj.-Gen. Monash took command of the Third Australian Division and his men were soon in the bloody welter of Passchendaele.

At Amiens his men held the Germans and he was chosen to command the Australian Corps with the rank of lieutenant-general.

His leadership, his inspiration to his men and a whole bag of tricks — he was an amateur conjurer — assisted him to



★ ABOVE: In 1886, John Monash was already taking an interest in soldiering and he was a Colour-Sergeant in the University Company, Victoria Rifles. This is one of many photographs from the book "John Monash."



put the enemy on the move, backwards, in France.

The Hindenburg break-through was the Australians' last great campaign and the last days of battle command for the spare-time soldier who had risen to the leadership of his country's army.

At one time, with Americans and others, Monash commanded 200,000 soldiers. On August 12, 1918, at Monash's own headquarters in France, King George V gave him the accolade of Knighthood.

He was now described as a leader who made up for a lack of front-line audacity with brain-power, organisation and relentless purpose.

Australian war historian, C.E.W. Bean, wrote that Monash had a resemblance in mentality with Napoleon that was striking; but lacked the Corsican's gambling instinct, replacing it with calculated prudence.

Field Marshal Lord Montgomery named Monash as the outstanding British Commander in WW1.

As a corps commander, occupying a bunk in the pantryman's cabin aboard the ship evacuating him from Gallipoli; Monash wrote:

"About 9 p.m., my last patrol...reported they could hear the Turks digging and putting out wire.

"This means that so far they suspected nothing....By 10 o'clock... only

1500 men were spread over eight miles.

"If at any point the Turks had discovered the withdrawal...many would have left their bones on the Peninsula.

"At 1.55 a.m. my last man left his foremost position, leaving only the automatic devices working....

"Down dozens of little gullies...came little gangs of six or a dozen men, closing the gully with a previously-prepared frame of barbed wire or lighting a fuse that an hour later would fire a mine....

"They coalesced into four lines....

"So well had everything been timed and so well had all kept the prescribed pace of three miles per hour that the heads of the lines reached the four beaches at the same time, onto the jetties and to the motor barges...

"The last act was to join the terminals of an electric battery that fired three enormous gun-cotton mines...at the Western Branch of Monash Valley.

"This brought a tornado of rifle and machine-gun fire that showed that the Turks, far from suspecting the truth, took the explosion to be the signal for an attack.

"We had succeeded in withdrawing 45,000 men, mules, guns, stores, provisions and transport without a single casualty.

"It was a most brilliant conception and will, I am sure, rank as the greatest joke in the whole range of Military History."

---

**THE portrait of Captain Reg Saunders, the first Aboriginal commissioned in the Australian Armed Forces, was formally hung in his presence on September 4.**

**The portrait has been placed alongside the Kapyong diorama, where Captain Saunders led a platoon.**

HARCOURT was his name and his battlefields ranged from the heights of Gallipoli to the snowy steppes of Russia, and the jungles of South-East Asia.

# Portrait of a global soldier

He was Maj. Harry Gladwyn Harcourt, who served with the British Army from 1914 to 1927 and whose service was spread from Britain, through France, Belgium, and Russia to India.

After the Armistice in 1918, he went to North Russia in command of a force known as Harcourt's Force, and which included British and Russian infantry, Royal Flying Corps troops, and a number of Australians.

In an exclusive article for ARMY Newspaper in 1968, Major Harcourt told of how he came to command this most unusual group.

"It so happens," Maj. Harcourt said, "that I was largely responsible for a number of Australians joining the North Russian Relief Force in 1919.

"In 1919 my family had many contacts with Australian Servicemen as my mother had regularly entertained them at her home.

While I held a regular commission in the 1st Battalion, The Royal Dublin Fusiliers — which Regiment many Diggers will remember from Gallipoli days where it was a unit in the famous 29th Division — I had specialised in machine guns and was seconded to the

Machine Gun /Corps and had served for a longish period with the 51st (Highland) Division.

In early 1919 I was in the UK attending a Staff course concerned with the post-war Army, when I heard of the situation in North Russia and I took myself to the 'War House' as we called the War Office and Headquarters, to see if offers to serve in Russia were being considered.

"Without going into tedious detail, I may say that subsequent to discussions, the powers that be decided that a Relief Force should be formed.

"Then, discussing the matter of 'bodies' to complete this unit I was told to go and find them!

"This was not difficult among British ranks, but owing to the number of Australians I had met at home, I wondered if any would be interested. So I took myself off to Horseferry Road and spoke to certain officers and a number of other ranks there.

"Among the latter I found great interest, but the officers were concerned with administrative details.

"Visits to the War Office established the fact that all ranks joining with the

## Herbes wants & Sabo.

NRRF would have to be British Army enlistments, and this entailed further visits to Horseferry Road.

"In the end it was established that any Australian Servicemen who wished to volunteer to serve the NRRF would be granted his discharge from the Australian Forces, and allowed to enlist in the British Services, who in turn agreed to the Australian authorities for repatriation after the North Russian affair was over.

"The War Office powers, in their own peculiar way, decided the infantry units to be formed to serve in the NRRF should be in the 45th and 46th Battalions, Royal Fusiliers — The City of London Regiment — and the 201st Battalion, The Machine Gun Corps, among others.

"I arranged for the enlistment of 400 to 500 Aussies in the British Army either in the Royal Fusilier battalions or the MG unit, and we gathered together and commenced settling down as units and then, in a very short time, embarked for North Russia — Archangel, to be exact."

The ships the Relief Force sailed to Archangel in were the SS *Czar* and the SS *Czarina*, as well as other smaller ships.

"Upon reaching Archangel, after about two or three days, I was ordered to move along the Archangel-Vologda Railway to engage the Bolsheviks wherever they were encountered and move as far south along the railway line as was practicable, if possible to Vologda.

"Subsequently we reached the station of Oberskaya, about 10-15 miles northwards from Emtsa, where we had to form a more fully-established form of forward area.

"We engaged in frequent patrols to establish the Bolshevik forward areas,

and when this had been done — say, some two or three miles northward of Emtsa — we planned to attack.

"At this time I was appointed? to command a mixed force of MGs, infantry some 45 and some 46 RF, gunners and an odd RFC detachment, which was known as 'Harcourt's Force', and we liaised as closely as practicable with the remainder of the 45 RF who, under command, I think, of a Major May, were on our left, or east of a river front — I've forgotten the name, but a tributary of the Severnaya Dvindi — where Bolshi forces were also located.

"Some time was spent in active patrolling to establish as positively as possible the fixed forward positions of the Bolshies, and, when this was done, we planned our attack and, as it happened, I was primarily responsible for this plan.

"The attack went on and generally we pushed the Bolshies out of both frontal areas and then settled down before the next advance which, we hoped, would take us southwards — to Vologda.

"However, as so often happens, the 'powers that be' had other ideas and we were all recalled to Archangel and from there to the UK and either demobilised or posted to our own regular units.

Maj. Harcourt came to Australia in 1929-30 on leave from the British Army in India, and "fell in love with the country so much I 'sent in my papers'."

"In 1939, not being allowed by the Australian authorities to vacate the appointment I held and return to the UK to rejoin a British Army unit, I was ultimately allowed to enlist in the 2nd AIF and had the privilege of serving with that force until 1946."

Following staff appointments in

## *Deni & pub details*

Australia, Maj. Harcourt later served with the 2/6th Australian Independent Company.

Maj. Harcourt also made a major contribution to the survival of the Allied cause in the dark days of WW2 with a jungle jaunt he made around 1928 in Burma.

Maj. Harcourt's love of the jungle, bred in the 1920s, probably saved thousands of lives, and tons of Allied supplies, when Burma fell to the Japanese.

About 1920, he found an alternative route between India and Burma during his jungle trips.

The find lay dormant — till the Japanese held the only other way out.

British intelligence, on appeal from India, recalled Maj. Harcourt's discovery.

It uncorked the bottleneck in Burma and allowed a stream of refugees to escape and Allied supplies to be spirited away from the enemy.

Maj. Harcourt later distinguished himself in WW2 in the Pacific theatre — despite being told that he was "too old".

Maj. Harcourt was the first officer to

reconnoitre the Kokoda Trail — scene of bitter fighting later on.

Soon afterwards, he was shipped home.

The Army said he was too old to continue.

Maj. Harcourt disagreed.

He badgered headquarters until a commando force was entrusted to his care.

It ravaged along the Pacific battleline as the enemy was progressively softened up.

The actions earned Maj. Harcourt the bar to his DSO.

Maj. Harcourt also won the U.S. Silver Star, two Russian medals and was MID three times.

Less known is that he was organiser and first secretary of the first World Scout Jamboree in Australia at Christmas, 1933-34.

He was also transport officer for the Royal Visit of 1954 in Tasmania.

Between 1952 and 1967, Maj. Harcourt was State secretary of the Tasmanian branch of the Legion of Ex-Servicemen and Women.

He was a legion life member.

He died in 1970 in the Hobart Repatriation Hospital.

---

**AUSTRALIA first mercenaries fought with the British Army in the Maori Wars of 1860-1872. When trouble broke out between the white New Zealand settlers and the Maoris early in 1860, the British Regiments stationed in New Zealand soon became hard pressed. They turned to the Australian mainland where a force of volunteers was raised. The men were offered land grants for their services.**

\* \* \* \*

**SOME 16,450 Australian soldiers saw service in South Africa during the Boer War, 1899-1902. We entered the war as a collection of six States; we emerged as a nation with our troops fighting under a common flag. Six Australians won the V.C. — the first to be awarded to Australians. All six later enlisted in the 1st AIF.**

# THE MILITARY HISTORICAL SOCIETY OF AUSTRALIA

PLEASE ADDRESS ALL CORRESPONDENCE

THE FEDERAL SECRETARY  
P.O. Box 30  
GARRAN  
A.C.T. 2605 AUSTRALIA

## APPLICATION FOR MEMBERSHIP

I/We .....of .....  
(Name, Rank, etc.) (Address)

hereby apply for membership of the MILITARY HISTORICAL SOCIETY of AUSTRALIA. I/We agree to abide by the Rules, etc., of Society and wish to be admitted as a Branch member of the .....  
Branch, Corresponding Member,  
Subscriber to Sabretache.

(Strike out non applicable alternatives.)

My main interests are .....  
.....

I/We enclose My/Our remittance for \$15.00 (Aust), being annual subscription, due 1st July each year.

.....  
Applicant's Signature

- N.B. (1) Regular Branch meetings are held in Brisbane, Canberra, Melbourne, Geelong, Adelaide and Perth.
- (2) Overseas Applicants are advised that subscription is \$15.00 Australian. Airmail delivery of Sabretache available for additional sum of \$10.00 Australian.



*Delete Not paid*



# MILITARIA

BOX 138 P.O.  
GRAFTON 2460

AUSTRALIA'S OLDEST ESTABLISHED  
FULL TIME MILITARIA

HELMETS

UNIFORMS

BOOKS

REBONS

DAGGERS

BADGES

MEDALS

ALL CURIOS BOUGHT AND SOLD

50¢ STAMPS FOR CATALOGUE





*Delete Not paid*



# The Armoury

296 BRIGHTON ROAD, NORTH BRIGHTON, SOUTH AUSTRALIA 5048

Michael Oleinkaff, J.P. Neville Gibson

Telephone: 08-2965126 AH 08-2935028 or 08-2962855

**WIDE RANGE OF MILITARIA AND  
WEAPONS IN STOCK**

**Will purchase individual or complete collections  
LISTS WILL CONTINUE ON A REGULAR BASIS  
FORWARDED TO REGULAR CUSTOMERS AND  
ALL WHO REQUEST.**

*Delete Not paid*



*Orders, Decorations  
& Medals*

9 ALBERT STREET, CLAREMONT, 6010  
WEST AUSTRALIA

Telephone  
31 4139

Telegraphic Address  
LUCKNOW, PERTH