

Military Historical Society of Australia  
*Sabretache*

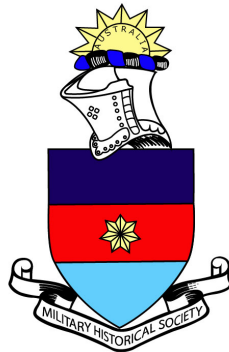

Copyright © 1957-2019 Military Historical Society of Australia on behalf of the Society and its authors who retain copyright of all their published material and articles. All Rights Reserved.

*Sabretache* policy is that the submission of material gives the Society permission to print your material, to allow the material to be included in digital databases such as the MHSa website, Australian Public Affairs-Full Text, INFORMIT and EBSCO. Reprints to non-profit historical and other societies will be approved provided suitable attribution is included and a copy of the reprint is sent to the author. Copyright remains with the author who may reprint his or her article or material from the article without seeking permission from the Society.

The Society encourages the download and distribution of *Sabretache* for personal use only and *Sabretache* can not be reproduced without the written consent of the Society.

[www.mhsa.org.au](http://www.mhsa.org.au)

Military Historical Society of Australia  
PO Box 5030, Garran, ACT 2605.  
email: [webmaster@mhsa.org.au](mailto:webmaster@mhsa.org.au)

---

# SABRETACHE

Vol XXX

April-June 1989

Number 2

Registered by Australia Post - Publication No. NBH 0587



# SABRETACHE



## The Journal and Proceedings of The Military Historical Society of Australia (founded 1957)

### Patron

Admiral Sir Anthony Synnot, KBE, AO

### Vice Patron

Major General R.N.L. Hopkins, CBE

### Honorary Office Bearers

#### President

Brigadier A.R. Roberts

#### Vice President

Major H. Zwillenberg, ED, (RL)

#### Secretary

Bronwyn Self  
P.O. Box 30, Garran, A.C.T. 2605  
Telephone (062) 43 4211 (bus.)

#### Treasurer

Mr N. Foldi

#### Editor

Stephen Allen  
G.P.O. Box 345, Canberra A.C.T. 2601  
(062) 43 4211

### Branch Secretaries

A.C.T.—Peter Sinfield, 14 Angophera Street, Rivett A.C.T. 2611

Victoria—Steve Gray, 12 Player Close, Hoppers Crossing, Vic. 3030

Geelong—Robin Mawson, 25 Allambee Avenue, Grovedale, Vic. 3216

Albury-Wodonga—Tony Peck, Lochiel, 615 Jones Street, Albury, N.S.W. 2640

Queensland—Mr S.W. Wigzell, 17 Royal Street, Alexandra Hills, Qld 4161

South Australia—Mr A.R. Clark, The Hermitage Drive, Anglsey Estate, Anglevale, S.A. 5117

Western Australia—Christopher Horvath, 32 Ash Way, Morley, W.A. 6062

## APRIL-JUNE 1989 VOLUME XXX-NUMBER 2

- 3 The Numerology of the Second AIF  
*Graham R. McKenzie-Smith*
- 12 Australians in Vietnam, 1940-41!  
*Paul de Pierres*
- 14 The Class of '42: Australian Imperial Force Officers of the Haifa Staff College  
*Kimberley John Lindsay*
- 19 North Head Barracks, Sydney  
*John S. Fenby*
- 23 The 121st Australian General Hospital, AIF, Katherine, 1942-43  
*Paul Rosenweig*
- 30 Colonel G.C. Somerville: Staff Officer and Administrator  
*John Haken*
- 35 Oh! For a shower of information  
*Neil Speed*
- 38 Wallace's Entrenching Tool in South Australia  
*A.F. Harris*
- 40 Boer War transports and first world war shipping losses — a comparison  
*Steve Duke*
- 41 *A relic of the Geranium*  
*Paul Rosenweig*
- 43 Book Reviews
- 45 Society Notes—Vale Bert Denman and George Vazeny

Contributions in the form of articles, book reviews, notes, queries or letters are always welcome. Authors of major articles are invited to submit a brief biographical note. The annual subscription to *Sabretache* is \$26.

Published by authority of the Federal Council of the Military Historical Society of Australia. The views expressed in the articles in this Journal are those of the contributors and not necessarily those of the Society.

## SABRETACHE

Hello after what seems like forever away from the typewriter. *Sabretache* is late again, but the editor has, to his regret, been occupied with other military historical matters over the past six months, notably the Australian War Memorial's annual military history conference. This was held from 3 to 7 July at the Australian Defence Force Academy in Canberra. This year's conference was made doubly interesting — and difficult — by the inaugural Australian naval history seminar.

Both events were highly successful, offering a valuable opportunity for academic and amateur alike to meet and discuss their approaches to military — and maritime — history.

It was pleasing to see many members of the MHSA attending both events — and presenting papers as well. Lindsay Cox and Lewis Scheuch—Evans gave an interesting and well-received presentation on historical re-enactment, and I presented a paper on the RAN's early involvement in the Pacific war. The Federal President, Tan Roberts, was able to attend as were other members of MHSA. Some, like John Price of MHSA Victoria, were able to attend both the conference and the preceding naval history seminar, showing both considerable interest and stamina!

The three-day programme of the naval history seminar highlighted a neglected field of historical endeavour in Australia — our nation's naval and maritime heritage. The convenors, Lt Cdr James Goldrick and Lt Tom Frame, are to be congratulated on their hard work and initiative in staging the event, organising the programme and obtaining sponsorship.

For those not able to attend either seminar or conference, alternate forms of information are available. As is usual, all except a few of the papers presented at the Memorial's conference were reproduced and many are still available, on application to the Memorial. Written papers were not reproduced for the naval history seminar, but a book of proceedings will be published in the near future. Those interested in obtaining a copy of the pro-

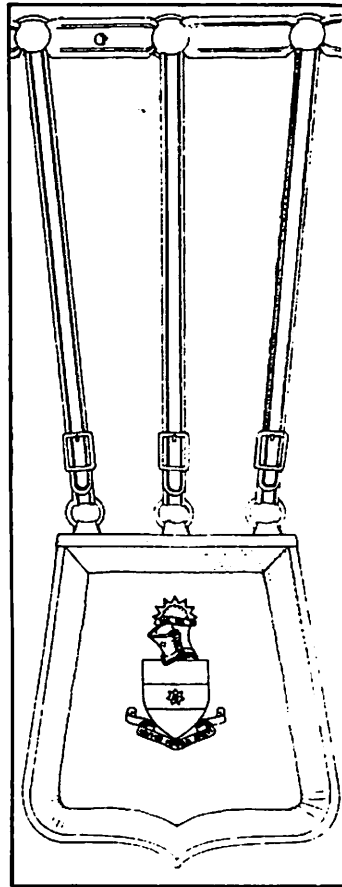

ceedings should contact Lt Tom Frame care of RO-CNS, A-4-14A, Navy Office, Russell Offices, Canberra, ACT 2600.

Back to the subject of late issues. Both the editor and Federal Council are painfully aware of the problem. We are attempting to respond to the desires of state branches for the production of *Sabretache* on time.

Balancing work and voluntary commitments is a hard act. I will, in any case, be resigning the editorship at the end of the year to take up full-time study in 1990. In the interim both myself and the Federal Council will be exploring ways of revamping *Sabretache* to ensure its continuation. I

would like to express my own appreciation for the forbearance and understanding of most members of the MHSA with late issues.

Opening hours for AWM research centre. Members should note that opening hours are 9.00 am to 4.30 pm, Monday to Friday, not 8.30 am as previously advised.

Contributions in recent issues of *Sabretache* have created considerable interest amongst members. In this issue Paul Rosenzweig is able to provide additional local interest to Greg Swinden's article on *HMAS Geranium*, while Neil Speed raises some interesting questions about Charles Ross, the 'neglected digger'. I'm also pleased to include Anthony Harris' contribution to 'Collector's Corner'. After a slow start this section looks like becoming a regular feature. Thanks to all contributors for this issue.

**Submit on Disk.** Contributors lucky enough to own or have access to a personal computer can now send material to *Sabretache* on floppy disk\*. This results in a considerable saving in time, as the material will not have to be rekeyed by our Typesetter, and a saving in cost as well. A hard copy will still have to be forwarded to allow editing to take place. Disks will be returned upon publication.

(\*Some compatibility restrictions do apply. Your editor will be supplied with accurate compatibility specifications.)

**Medal Man Returns!** John Burrige, of MHSA Western Australia, will be sub-editing a regular page of information and contributions designed specifically for members interested in medals. Contributions to 'medal man' should be sent direct to John, care of the MHSA Western Australia address printed on the contents page of *Sabretache*. Members with expertise in other areas of collecting or militaria e.g. uniforms, firearms, may consider a similar sub-editing role on either a regular or semi-regular basis. *Sabretache* is also looking for a book review sub-editor, to handle distribution and sub-editing tasks concerned with book reviews.

Graham R. McKenzie Smith

## The Numerology of the Second AIF (Infantry) 1939 to 1945

### Introduction

During the second world war, Australia raised an expeditionary force of four infantry divisions, an armoured division and all associated arms and services. The infantry force was made up of 12 brigades and 36 battalions.

An examination of Table 1 shows the numbering system adopted for these battalions and their grouping into brigades and divisions. This article sets out to explain how a combination of tradition, circumstance, personal animosity between commanders, political pressure and other factors combined to result in a unit nomenclature and grouping that at first glance seems illogical. This is the numerology of the Second AIF.

### The tradition from the First AIF

The Great War of 1914–18 saw the young men of Australia rush to assist the mother country and to take part in a great adventure. From this influx of men the Australian Imperial Force (AIF) was formed and organized into 5 divisions, 15 brigades and 60 battalions which were numbered sequentially. In a subsequent article of this series the numerology of the First AIF will be examined.

After the Great War, methods were sought to allow the transition and comradeship forged in battle to be carried forward into the militia units that made up the peacetime Australian army. In 1921 the militia (partly volunteer, partly conscript) was reorganized to reflect the divisional organization of the AIF. This resulted in the formation of 15 brigades with 60 battalions of infantry, each taking on the format, name and traditions of the equivalent unit of the AIF.

The battalion numbers allocated to each state in 1921 are shown in Table 2.

The period 1921 to 1939 saw major reductions in the peacetime militia and many units formed in 1921 were reduced to cadres, especially in 1929 when the Scullin government abolished conscription. Some units were disbanded but their traditions were continued by creation of linked units. For example 23/21 Bn carried on the traditions of both its parent battalions from when they were linked in 1929 until it was disbanded in August 1943.

At the outbreak of the second world war the Australian Army contained 5 divisions, 15 brigades and 45 battalions which through linking maintained the traditions of all 60 battalions of the First AIF.

### Formation of the Second AIF

In September 1939, the prime minister (Mr Menzies) announced that an expeditionary force (to be known as the Second AIF) would be formed for service at home or overseas. This force would consist of an infantry division and associated troops using the model of the 1st Division of the 1st AIF.

As the militia contained 5 divisions and 15 brigades, the new formation was to be known as the 6th Division, made up of the 16th, 17th and 18th Brigades each of 4 battalions. Rather than commence numbering the battalions from 61 it was decided to use the original numbers from the first AIF with the prefix '2nd' before each name.

From New South Wales the 16th Bde was formed with 2/1st Bn, 2/2nd Bn, 2/3rd Bn and 2/4th Bn while in Victoria the 2/5th Bn, 2/6th Bn, 2/7th Bn and 2/8th Bn formed the 17th Bde. The smaller states contributed to the 18th Bde with 2/9th Bn (Qld), 2/10th Bn (SA) and 2/11th Bn (WA).

The 12th Bn of the 1st AIF was formed from Tasmania, South Australia and Western Australia, but differences in relative population growth between 1914 and 1939 resulted in the 2/12th Bn being formed in Tasmania and Queensland.

As well as reflecting the numbering of the 1st AIF battalions these numbers also reflected the number of the senior militia battalions from each state (refer Table 2).

The structure of the 6th Division at its formation is shown in Table 3.

### Formation of the 7th Division

The first convoy of the AIF (containing the 16th Bde and associated units) had departed for the Middle-East before the War Cabinet decided on 28 February 1940 to expand the AIF to a corps of two divisions. At the same time it was decided to adopt the British divisional structure which contained only three battalions in each brigade.

ORGANIZATION OF SECOND A.I.F. INFANTRY

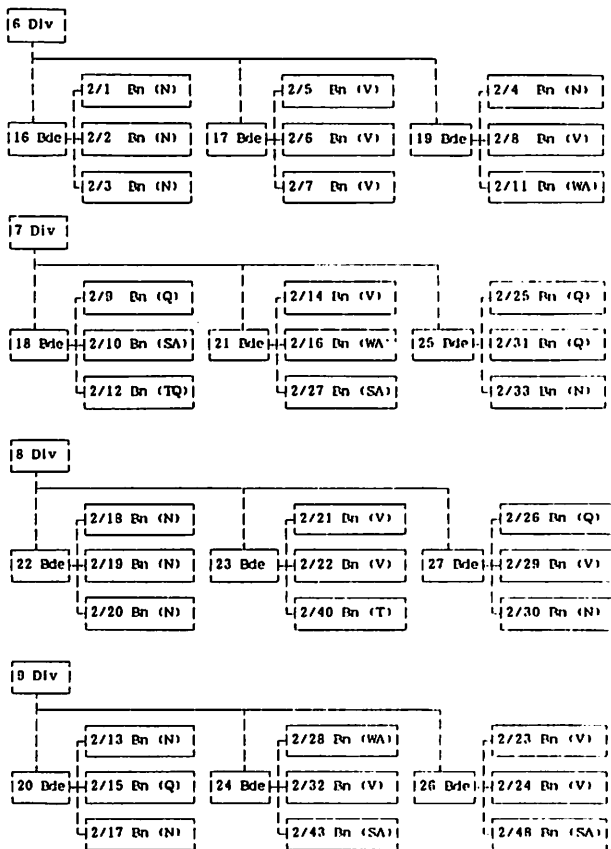

BATTALION NUMBERS ALLOCATED TO EACH STATE DURING THE REORGANIZATION OF MILITIA IN 1921

Source M.O. 95/1921

N.S.W.	Vic	Qld	W.A.
1 Bn	5 Bn	9 Bn	11 Bn
2 Bn	6 Bn	15 Bn	16 Bn
3 Bn	7 Bn	25 Bn	28 Bn
4 Bn	8 Bn	26 Bn	44 Bn
13 Bn	14 Bn	31 Bn	
17 Bn	21 Bn	42 Bn	
18 Bn	22 Bn	47 Bn	
19 Bn	23 Bn	49 Bn	
20 Bn	24 Bn		
30 Bn	29 Bn	S.A.	Tas
33 Bn	32 Bn	10 Bn	12 Bn
34 Bn	37 Bn	27 Bn	40 Bn
35 Bn	38 Bn	43 Bn	*51 Bn
36 Bn	39 Bn	*50 Bn	*52 Bn
41 Bn	46 Bn		
45 Bn	*48 Bn	Note: *Subsequently:-	
53 Bn	57 Bn	48 Bn Vic to S.A (1930)	
54 Bn	58 Bn	51 Bn Tas to NSW (1930)	
55 Bn	59 Bn	52 Bn Tas to Vic (1930)	
56 Bn	60 Bn	50 Bn S.A to Tas (1937)	
		51 Bn NSW to Qld (1937)	

ORGANIZATION OF 6 DIV, DECEMBER 1939

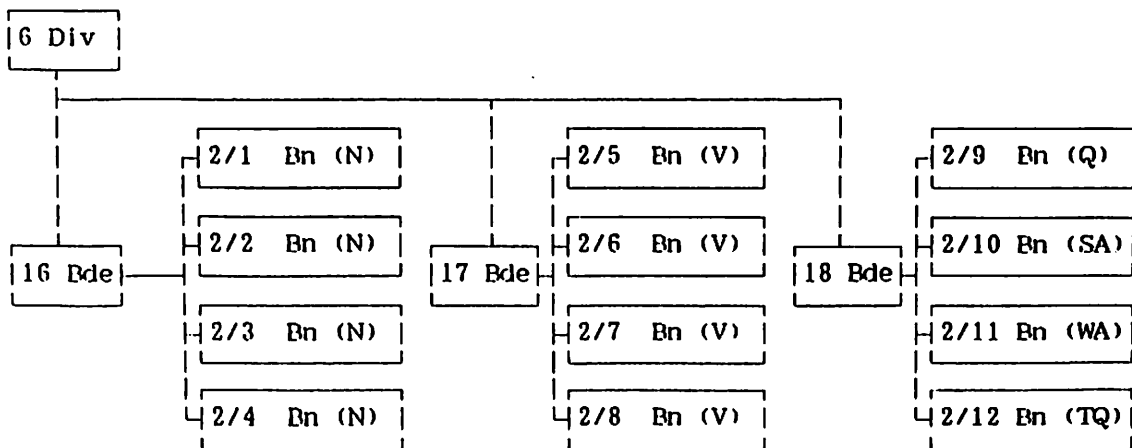

The first brigade (19th Bde) of the new division (7th Division) was to be formed using the fourth battalion from each of the 6th Division brigades. Thus the 19th Brigade was to include the 2/4th Bn (NSW), 2/8th Bn (Vic) and 2/12th Bn (Tas, Qld).

The remaining 2 brigades to be formed (20th Bde and 21st Bde) would require six battalions which were allocated to Queensland (1), New South Wales (2), Victoria (1), South Australia (1) and Western Australia (1) on the basis of recent recruiting figures. At the same time a large number of corps units such as pioneer and machine-gun battalions, engineer and artillery units were formed and these were taken into account when determining the regional distribution of the infantry units.

The two infantry battalions to be formed in New South Wales adopted their numbers from the next most senior militia battalion numbers from that state. They then became the 2/13th Bn and the 2/17th Bn. Similarly the Queensland battalion adopted the title of the 2/15th Bn and together with the New South Wales units formed the 20th Brigade. The battalions formed in their home states in May 1940 and moved to the Middle East in November 1940.

The next available unit number in Victoria was the 2/14th Bn and in Western Australia was the 2/16th Bn. Together with the 2/27th Bn from South Australia these battalions formed the 21st Bde. The battalions formed in their home states in May 1940 but did not come together as a brigade until they arrived in Palestine in November 1940.

In May 1940 the proposed infantry composition of the 1st Australian Corps is shown in Table 4.

**Formation of the 8th Division**

The War Cabinet decided on 22 May, 1940 to increase the AIF to three divisions to utilise the rush of men offering their services following the fall of France.

One brigade (22nd Bde) was formed in July with three battalions from New South Wales. These were numbered 2/18th Bn, 2/19th Bn and 2/20th Bn as these were the next available militia numbers from that state. The brigade assembled at Ingleburn (NSW) in early August 1940.

The second brigade (23rd Bde) was formed in July with two battalions from Victoria which took their numbers from the next available militia battalion numbers from that state (2/21st Bn and 2/22nd Bn). The remaining battalion was to be formed with its headquarters and one company from Tasmania and three companies from Victoria. It was to take its number from the next available Tasmanian militia unit (i.e. 2/40th Bn). The brigade assembled at Seymour (Vic) in late July 1940.

The third brigade (24th Bde) was also formed in July 1940 from the smaller states with 2/25th Bn from Queensland, 2/28th Bn from Western Australia and 2/43rd Bn from South Australia. The Brigade did not assemble until they arrived in the Middle-East in early 1941.

Thus the original infantry component of the 8th Division was planned to be as shown in Table 5.



ORGANIZATION OF 1 AUST CORPS  
MAY 1940

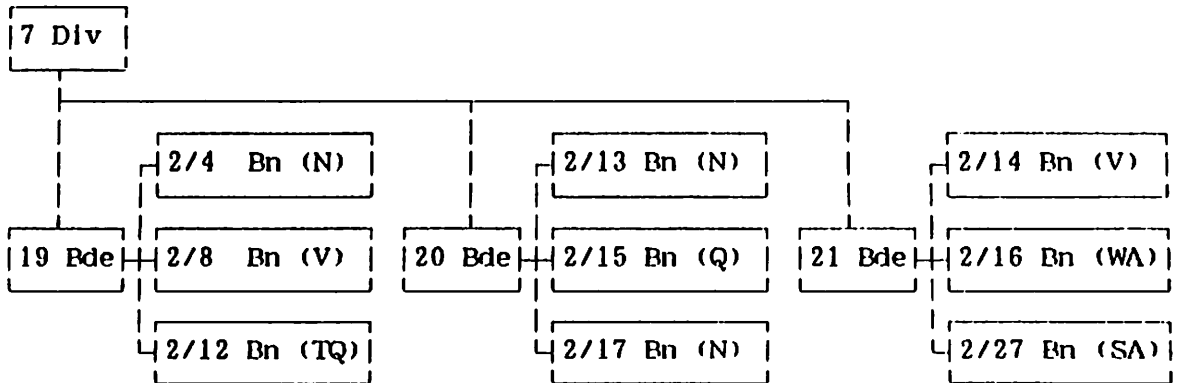
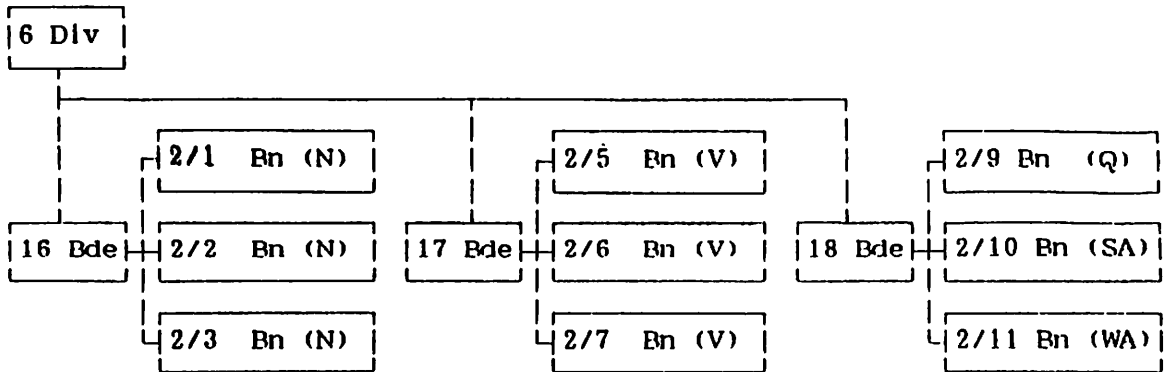

ORGANIZATION OF 8 DIV - AUGUST 1940

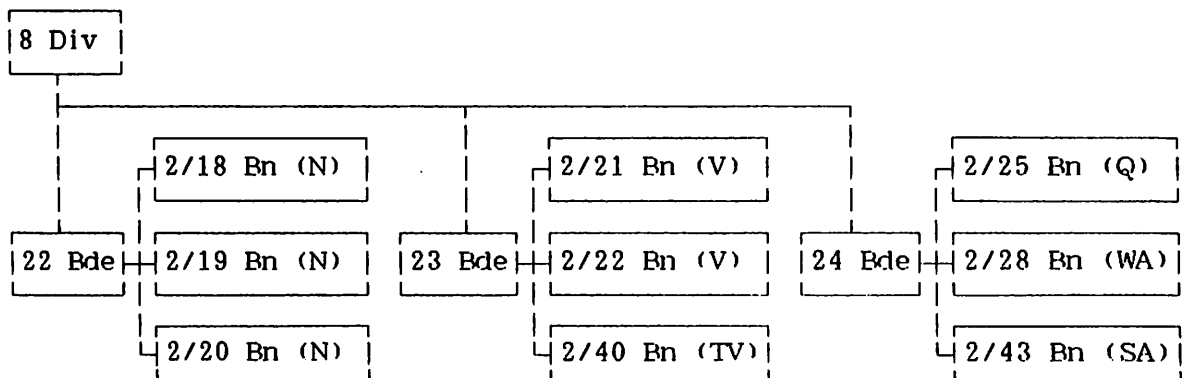

### Diversion of the third convoy

The first AIF convoy to the Middle-East sailed in January, 1940, and contained the 16th Brigade group as it was originally formed with four battalions (2/1st Bn, 2/2nd Bn, 2/3rd Bn and 2/4th Bn).

The second convoy sailed in April 1940 and as well as containing the four battalions of the 17th Brigade (2/5th Bn, 2/6th Bn, 2/7th Bn and 2/8th Bn) it also included the 2/11th Bn from the 18th Brigade. This Western Australian unit joined the second convoy in Perth after taking pre-embarkation leave rather than return to Sydney to join the third convoy which was due to sail one month later.

The third convoy left Australia in May 1940 and included the 18th Brigade, many infantry reinforcements and specialist corp troops such as engineers, artillery, signals and service corps. As Italy entered the war in June 1940 the convoy was re-routed to England to avoid the then Italian dominated Red Sea and to reinforce the post-Dunkirk army in England waiting for the expected German invasion.

The diversion resulted in the 2/11th Bn already in the Middle-East being used to form the 19th Brigade instead of the 2/12th Bn which by then was in England. The 19th Brigade was formed in Palestine in June 1940 and transferred to the 6th Division to replace the diverted 18th Brigade to allow the 6th Division to be available for operations in the Western Desert Campaign.

The third convoy arrived in England at the height of the invasion scare of summer 1940 and the 18th Brigade was given an immediate role in the defence of the United Kingdom. The specialist corp units in the convoy did not have an immediate role due to the lack of specialist equipment after Dunkirk and were re-organized as another infantry brigade as a temporary measure.

This brigade was called the 25th Brigade and the battalions named 70th Bn, 71st Bn and 72nd Bn. The whole force was named 'AUSTRAL FORCE' under Major-General Wynter.

At the end of July 1940 the infantry of the Second AIF was organized as shown in Table 6.

### Completion of the 7th Division

In August 1940 the War Cabinet accepted that 'AUSTRAL FORCE' would be required in the UK for some time and as the 19th Brigade had been transferred to complete the 6th Division in the Middle-East another brigade was required to complete the 7th Division prior to them leaving Australia in November.

This new brigade was made up of two battalions from Victoria (numbered 2/23rd Bn and 2/24th Bn) and one from South Australia (2/48th Bn). The manpower for the 2/24th Bn was partly provided by transforming the three Victorian companies from 2/40th Bn (part of the 23rd Bde, 8th Division). This allowed Tasmania to provide the whole of the 2/40th Bn, the

only wholly Tasmanian battalion to be formed during the war, and eased the pressure from Tasmanian politicians and public opinion.

The Victorian battalions concentrated at Wangaratta (Vic) in September 1940 and the brigade arrived in the Middle-East in December 1940.

### Formation of the 9th Division

On 23 September 1940 the War Cabinet decided to form another division for the Second AIF with 'AUSTRAL FORCE' as its nucleus.

The battalions of the 25th Bde (70th Bn, 71st Bn and 72nd Bn) were renumbered 2/31st Bn, 2/32nd Bn and 2/33rd Bn and became a permanent part of the AIF. Although these battalions had no specific geographical basis they were deemed to have been formed in Queensland, Victoria and New South Wales respectively as the corresponding militia battalions came from these states.

It was originally proposed to form another brigade in Australia from recent recruits to complete the infantry of the 9th Division. However, General Blamey as GOC of the AIF pointed out that the 18th Brigade and 25th Brigade consisted of men recruited in late 1939 who at that stage had 12 months' experience and that the 9th Division should be completed by transferring a trained brigade from Australia. As a result the 24th Brigade (8th Division) was transferred and left for the Middle-East in January 1941.

The 18th Brigade transferred to the Middle-East from Britain in December 1940 and the 25th Brigade arrived in March 1941.

To replace the 24th Brigade in the 8th Division a new brigade (27th Bde) was formed in October 1940. The battalions were formed in Queensland (2/26th Bn), Victoria (2/29th Bn) and New South Wales (2/30th Bn) and concentrated at Bathurst (NSW) in March 1941. Again the battalion numbers were derived from the next most senior militia battalion numbers in each state.

In early February 1941 the Second AIF was concentrated in the Middle-East except for the 8th Division which had been retained in Australia for service in Malaya in the event that Japan entered the war. Divisional Headquarters and the 22nd Brigade moved to Malaya in February 1941 while the 23rd Brigade and 27th Brigade remained in Australia.

The infantry component of the Second AIF in mid-February 1941 is shown in Table 7.

### Restructuring the AIF — March 1941

On 26 February 1941 General Blamey gave instructions for the re-organization of the Second AIF in the Middle-East.

After its victorious Western Desert campaign the 6th Division was to be relieved of its garrison duties by the 9th Division so it could prepare for more active duty in Greece. As the 7th Division was also due to

ORGANIZATION OF SECOND A.I.F.  
JULY 1940

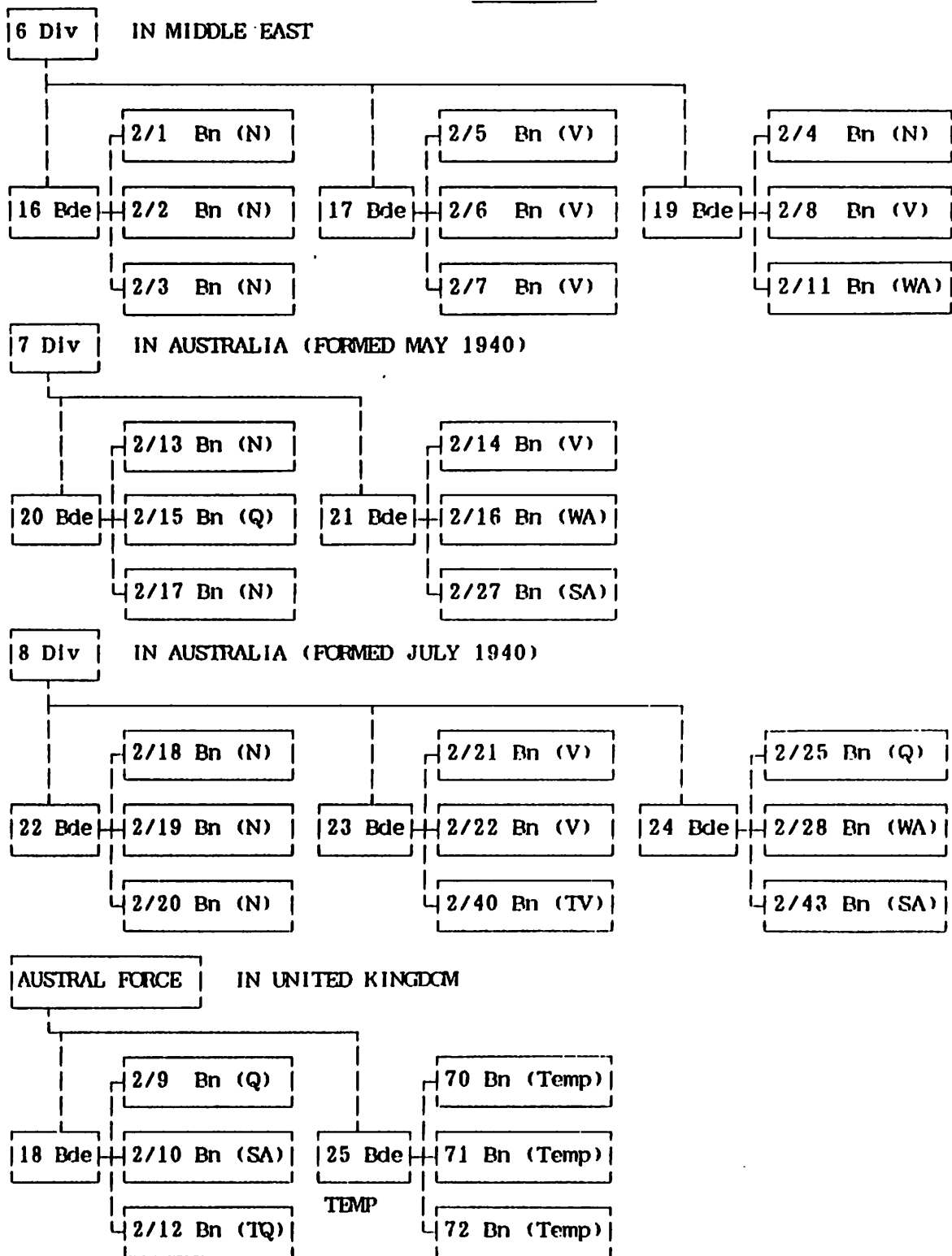

ORGANIZATION OF SECOND A.I.F.  
MID FEBRUARY 1941

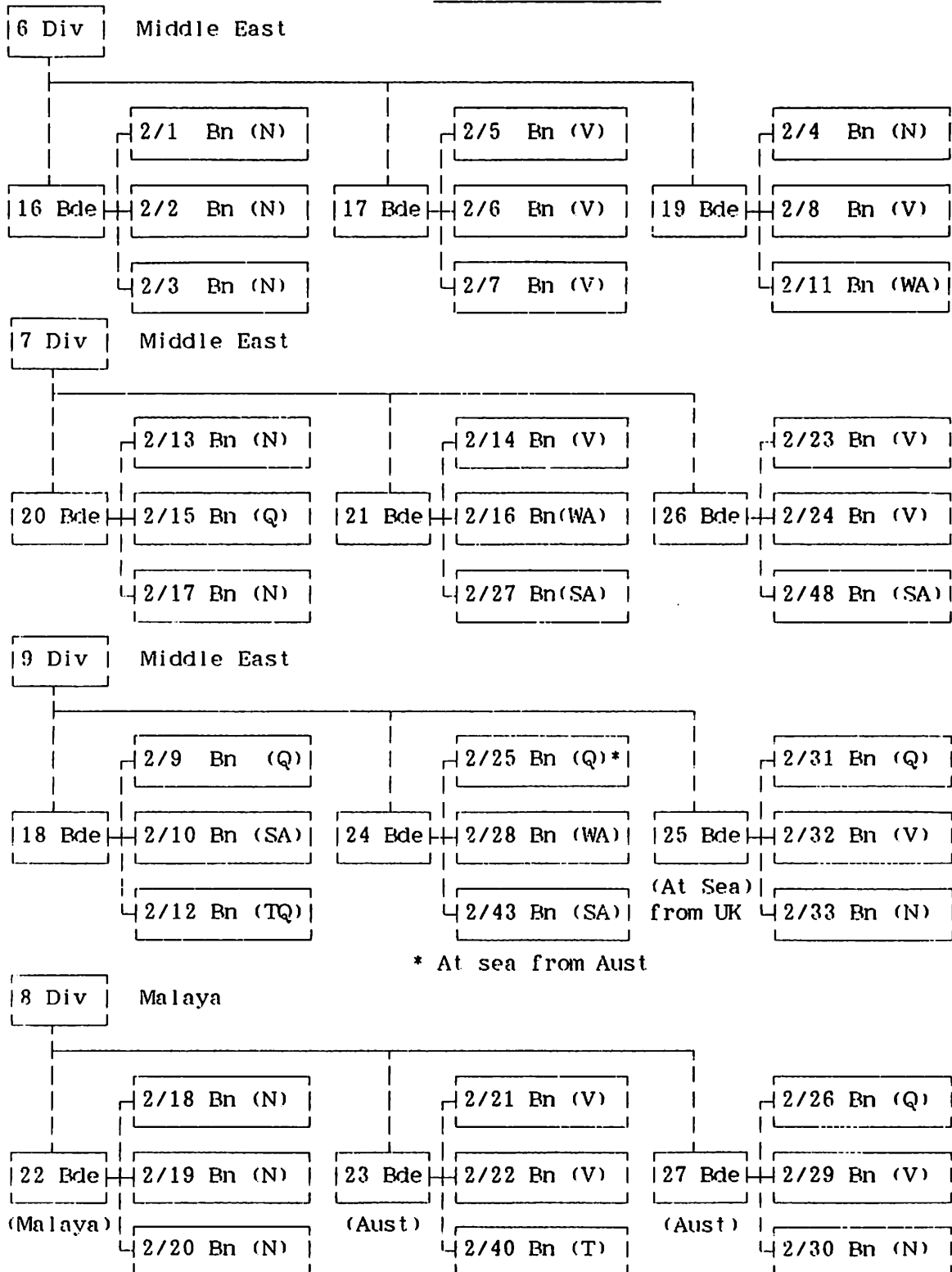

move to Greece to face the German Army the brigades of the 7th Division and the 9th Division were re-organised on the basis that the more experienced and better-trained troops would be in the 7th Division.

As a result the 18th Brigade and the 25th Brigade were transferred into the 7th Division and the 20th Brigade and the 26th Brigade were transferred to the 9th Division so that they could continue their training in the more peaceful environment of Western Desert garrison duties. The choice of the 26th Brigade (formed in August 1940) was obvious but the choice of the 20th Brigade for transfer rather than the 21st Brigade (both formed May 1940) appears to be based on personal differences between Blamey and Brigadier Murray (CO 20th Bde).

### **Final structure of the Second AIF**

As with many great plans the unexpected happened in that the 9th Division found itself actively fighting the German Afrika Corp at Tobruk while the 7th Division missed the Greek battles and remained in Palestine.

When the 24th Brigade was sent from Australia to complete the 9th Division it sailed without the 2/25th Bn which had been sent to Darwin for garrison duties. By the time the battalion was released and sent to the Middle-East, the 24th Brigade was actively engaged at Tobruk. To complete the infantry of the 9th Division, 2/32nd Bn was transferred from the 25th Brigade to the 24th Brigade and when the 2/25th Bn arrived in the Middle-East in April 1941 it was transferred to the 25th Brigade.

The final organization of the infantry battalions of the Second AIF is as shown on Table 8 and except for temporary regroupings in the heat of battle the units worked together in these groups throughout the rest of the second world war.

In the Japanese advance of December 1941 to February 1942, the 8th Division with the 22nd Brigade and 27th Brigade were captured in Singapore and were removed from the Order of Battle. The battalions of the 23rd Brigade were also captured at Ambon (2/21st Bn), Rabaul (2/22nd Bn) and Timor (2/40th Bn). The headquarters of the 23rd Brigade remained at Darwin and militia battalions (7th Bn, 8th Bn and 27th Bn) were transferred from the southern states to complete the brigade.

### **Conclusion**

The numerology of the Second AIF does have a pattern to it and that pattern is an amalgam of tradition, circumstance, personal difference and political influence. This pattern is continued to day in the naming of Army Reserve infantry units which help to keep alive Australia's military heritage.

ORGANIZATION OF SECOND A.I.F.  
APRIL 1941 TO 1945

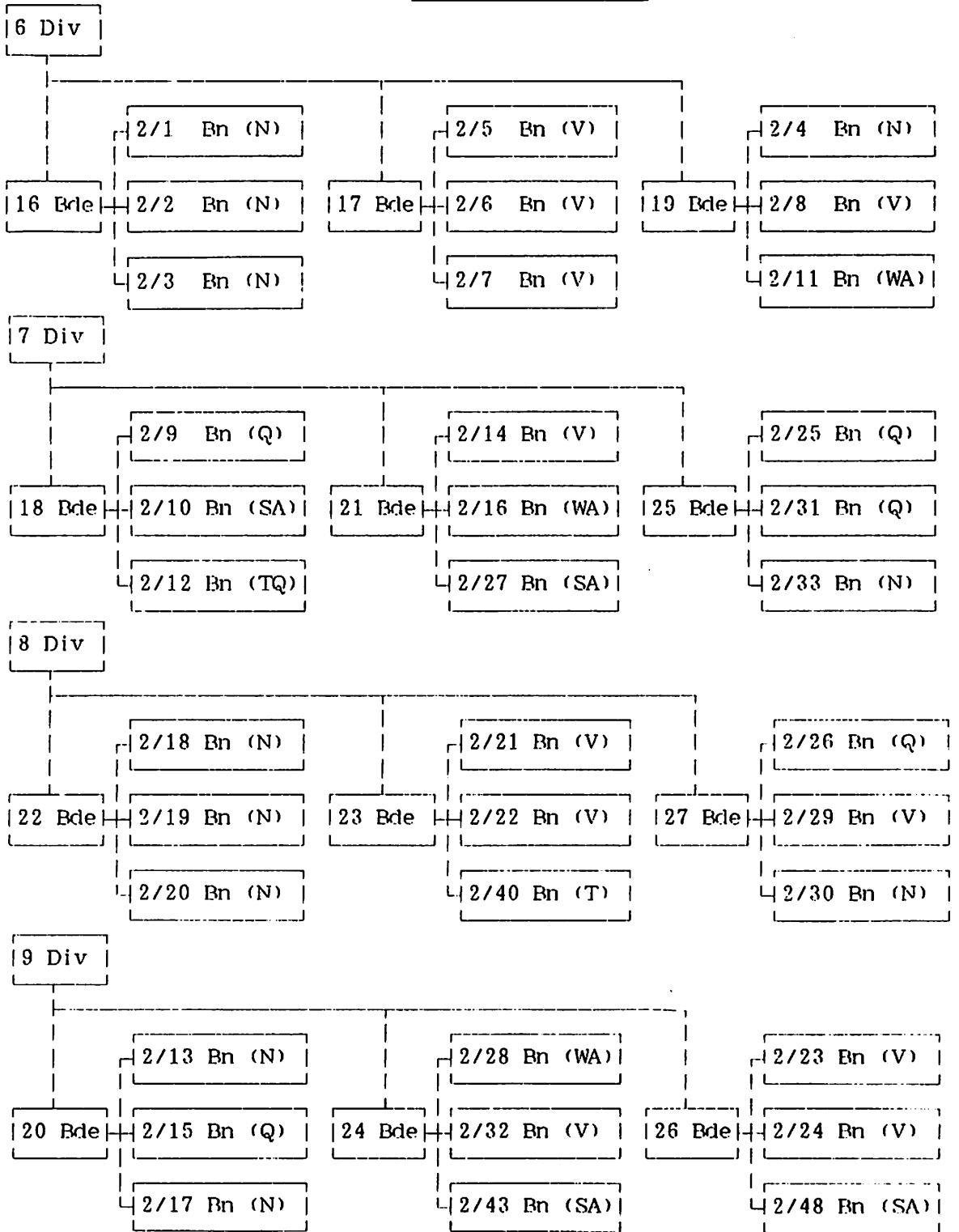

*Paul de Pierres*

## Australians in Vietnam, 1940–41!

**A**t the outbreak of war in 1939 France's mobilisation system worked incredibly well, in fact far more efficiently than her armed forces, generally speaking, were to fight in the dark days of 1940.

Amongst those called to the colours at that time were the French nationals resident in Australia. These men, some sixty in number, were following a diversity of occupations around the country from labourers to anthropologists and included some seventeen wool buyers and one farmer, my late father Stanley de Pierres.

Once mobilised these Australian-based reservists departed in two drafts on 9 December 1939 and 28 March 1940 aboard the *Pierre Loti* for Saigon and Noumea. This vessel, of some 5140 tonnes, was formerly the private yacht of Nicholas, last of the Russian Czars.

On arrival in Saigon these 'Australian' Frenchmen were sent to the large transition depot from where they were posted to various French units in Tonkin, Annam and Cochin-China. It seems that the majority of them ended up in artillery regiments as did my father who was sent to the 7th Battery of the 5th Colonial Artillery Regiment at Cap St Jacques, better known to many of us as Vung Tau. However some were sent to the infantry, notably the 11th Colonial Infantry Regiment, which was later to gain notoriety towards the end of the war when General Gracey's 20th Indian Division liberated Saigon from the Japanese.

The French Army in Indochina at this time was poorly-equipped and pay and conditions were bad. For inland operations the 5th RAC were using mule-borne World War I vintage 'soixante-quinze de montagne' (75mm pack Howitzers) which though they had been known affectionately as 'the Father, the Son and the Holy Ghost' for their marvellous performance during the Great War were now out of date. For coastal defence they employed captured German naval guns (150mm) manufactured around the turn of the century. Small arms were mainly the five shot 8mm Berthier; carbine and automatic weapons were scarce.

During this period the French Indochina Army were involved in major incidents, notably with the Thais and the Japanese and the continuing mood of antagonism against the French by the various Vietnamese nationalist movements guaranteed that the reservists from Australia saw 'active' service.

Between September and December 1940 the Japanese in Southern China demanded use of the port facilities at Haiphong to embark troops. When the French authorities refused there was a series of sharp actions around Langson in North Vietnam and amongst the heavy French casualties was Lt Paul Robin, a reservist from Australia and a wool buyer before his war service. The French also fought a short war at the same time (November 1940-February 1941) with the Thais — then called Siamese — over their territorial ambitions in the French Protectorate of Cambodia. Whilst the regulars of the 5th Foreign Legion Infantry Regiment bore the brunt of the fighting reservists were engaged in various ancillary units.

In May 1941 the French Vichy Government completed an agreement of co-existence with the Japanese for Indochina. In fact there was little choice as the Colonial Army would have been quickly overwhelmed by the vastly superior Japanese forces in the region. Meanwhile the reservists from Australia, luckily for them, were offered demobilisation and return home which it is believed they accepted to a man.

The first draft departed successfully for Australia during May 1941 however the second draft, which included my father, was unable to get on a suitable ship for some weeks. Finally in June they embarked for Shanghai in China where they saw the strange sight of Italian, British and French warships peacefully at anchor. After a week at the French Concession which the Japanese still respected at this stage they managed to get on a small tramp-steamer which was taking some captured pirates under armed guard to Hong Kong.

From here things improved dramatically as they were put aboard the *MV Neptuna* (later to be sunk at

Darwin) and departed Hong Kong for Sydney on 18th June 1941. Further drama ensued however as they struck a typhoon in the South China Sea and a large bulldozer was torn off the deck during the storm. Brief stops were made at Manila, Rabaul and Lae before the *Neptuna* berthed at Sydney on 20 July 1941.

For some of the French reservists the war was not over as they volunteered for service with de Gaulle's Free French and went to North Africa. It is quite possible that some of them served with the AIF, as my father volunteered on 25 February 1942 and though initially accepted was later 'manpowered' because his brother had joined the RAAF and their ageing father was trying to run the family farm. He did join the local

VDC battalion and served with it until the end of the war from which his brother was not to return.

For their war service in Indochina the French reservists were entitled to the following three medals: The Combattants' Cross, which is roughly equivalent to the 1939-45 star; the Colonial Medal with the bar 'Indochine'; and the 1939-45 War Medal with bar 'Extreme Orient'. In addition my father received the Australia Service Medal for his three years in the VDC.

Many of the families of these reservists live in Australia today and are truly Australian 'nationals'. Perhaps some of their sons also had a feeling of *deja vu* as I did when I saw the hills at Vung Tau in February 1971, thirty years after my father had been stationed on them.





*Kimberley John Lindsay*

## The Class of '42: Australian Imperial Force Officers at the Haifa Staff College

**H**aifa Staff College came into existence in 1940, when enemy action made it impossible to send students direct through the Mediterranean to courses in the UK and the alternative route around the Cape involved too much delay. Its purpose was to train officers of the Middle-East Forces to hold first and second grade staff appointments. Originally called the Middle-East Staff School it was renamed Haifa Staff College to emphasize its affinity with Camberley Staff College, on which it was modelled, and with Quetta Staff College.

The Teltsch Hotel (known as Teltsch House), a large modern building, standing above the sea one one of the spurs of Mount Carmel about two miles south of Haifa, was requisitioned to provide a lecture room, Walls of Study and Mess.<sup>1</sup>

The first 'War Staff Course' commenced in January 1940. Altogether, until the last course ended in October 1946, 15 War Staff Courses were held. Australians had left the scene by 1943, but were well represented in the earlier courses.

'The Class of '42' in question, was the 6th War Course, which ran from 31 January 1942 to 23 May 1942. The Commandant, who succeeded Brigadier Dorman-Smith, MC, was Brigadier Gerald Knocker Dibb, CBE, MC. He had been decorated with the Military Cross, Légion d'Honneur and Mentioned in Despatches with the Royal Field Artillery on the Salonika Front in the First War. Before the Second War, Dibb had been in India, as an instructor at Quetta Staff College.<sup>2</sup>

Brigadier Dibb had a Directing Staff (DS) of twenty, including two chief instructors (G1) with the local rank of colonel, and the Adjutant. For the first time, the college was to be divided into three Wings: General Staff (G), Administration and Quartermaster (AQ), and Royal Air Force (RAF).<sup>3</sup> This division of G and AQ was not sound and was later changed. The RAF Wing later developed into an independent college.

The G1, AQ Wing, Brigadier A.C.F. Jackson, CVO, CBE, recalled that: 'the College was commanded by a very pleasant brigadier who I never met before and, in our first conversation, I sensed that he had the same misgivings as I had (about dividing (G and AQ). There

was no object in voicing them as the new course was due to start in about two weeks' time and there was not even a syllabus arranged. GHQ, Cairo had provided me with about six first class majors (local lieutenant-colonels) as my instructors and, after one or two conferences, we managed to get things sorted out. I did have to get considerable cooperation from the other wing who were supposed to be teaching operational staff officers, so we did much of the work together.'<sup>4</sup>

One of these 'first class majors', the late Brigadier John ('Jock') Sorel-Cameron, CBE, DSO, DL, had been a student on the first course and was quite clear about Haifa Staff College: 'It was the best of the three Staff Colleges (Camberley, Quetta and Haifa), mainly because 'every officer there, DS or student, had been in battle and knew what the score was. Any visiting lecturer talking "b\*\*\*-s\*\*t" was quickly put in his place.'<sup>5</sup>

The students on the 6th War Course numbered 114, the majority of these being British Regular Army officers of Infantry regiments, Royal Armoured Corps, Royal Artillery (Field and Anti-Aircraft), Royal Signals, Royal Army Service Corps, Royal Army Ordnance Corps, Royal Army Medical Corps and Royal Marines, plus British officers from Malta and East Africa. In addition there were eight officers of the New Zealand Expeditionary Force, twenty Australian Imperial Force officers, sixteen Union Defence Force officers from South Africa, one Southern Rhodesia Staff Corps officer and eight RAF officers (five of them pilots).

As the 6th course progressed, a few naval officers joined. Apart from lectures by the Directing Staff (DS), students were also selected to give lectures, which was considered an honour, as was indeed selection to the staff college, as DS or student. 'This in peace time, would have been looked upon as one of the best posts one could get; even in wartime, it was a great compliment.'<sup>6</sup>

One of the Australians, Philip Parbury, DSO, MC, thought that, 'it was in many ways a unique course at that time. The Australian contingent was strong; two future chiefs of the general staff (Australia) and a number of others obtained high rank.'<sup>7</sup>



*Haifa Staff College, Teltsch Hotel, Mt Carmel, Haifa.*



*Haifa Staff College, Jan 1942. 'AQ' Wing, AIF and NZEF students. (Back row): T/Maj J.M. Rodd (later CBE); Maj G.N. Godsall (Lt-Col); Capt T.W. Young (Brig, OBE); Capt E.D. Mackinnon (MHR; Australian Ambassador; CBE); Maj R.R. Gordon (Maj-Gen, AM, CBE, DSO, ED). Front row: Capt A.K. Blaubaum (Maj); Maj A.P. Bennett (Lt-Col); Capt J.G. Lindsay, MC (Maj); Capt A.D. Copeland (Ltd-Col, ED); Maj B. Barrington (Brig, DSO, OBE, ED); Capt E.J. Horwood (Maj).*

Major-General Roy Gordon, AM, CBE, DSO, ED, who was in the AQ Wing, explained that:

our course was divided into two separate sections — the G Wing and the AQ Wing. The reason for this was that in previous courses they found that there was too much to cover to train all officers in all aspects of staff work in the time available. I believe age had a lot to do with whether one was in the 'G' or 'AQ' Wings. It was the practice during the course to spread us over the various syndicates. Consequently we Australians were never in the same syndicate and rarely saw much of each other. The course was a very strenuous one and we had very little time to mix with our fellow students.

Your father and I were in the AQ Wing, together with Major Bennett, Capt Blaubaum, Major Godsall, Capt Mackinnon, Major Rodd and Capt Young. There were also three New Zealand officers with us: Capt Copeland, Major Barrington and Capt Horwood. During the course we were all required to be prepared to give a lecture to the Assembly on any subject we cared to choose and the DS selected the lectures to be given.<sup>8</sup>

Brigadier T.W. Young, OBE, a Royal Military College Duntroon graduate, confirmed that:

it was a very concentrated course and my recollection of it is that we had very little social life for its duration. I remember being somewhat disappointed at finding myself on the AQ Wing when I had aspirations for a G career. However the powers to be knew best and Haifa set the pattern for the majority of my Army postings.<sup>9</sup>

It was supposed to be an honour to be selected for the course and was much sought after, especially by the British officers. But most of us I think would have preferred to be in our fighting Units that on the staff. I believe the idea was to push into four months the Course at Camberley which covers two years. Hence the pressure on us. Certainly the course was a good one and the instruction was excellent. The mixture of the officers from quarters of the allied armies was in itself most interesting and helpful as was also the mixture of professional and non-professional Soldiers. The English students were almost all Regular Soldiers, most of who had had many years service. They were certainly good, but no better than the Regulars in our Australian contingent, but certainly more experienced than we non-regular Australians. The English officers were very skilled at answering questions in general discussion periods — they had had a lot of experience at it in many different schools and courses and were past masters at speaking for 20 minutes without any apparent reference to the subject in hand.' (Major-General Gordon)<sup>10</sup>

On Saturday nights we went to one of the local pubs-cum-dance cabarets, where a drink could be enjoyed, and where you could dance with a wench if you bought her champagne. On Sunday evenings we caught the local bus to the pictures and returned early. There was a welcome three days' mid-term break, from 20 to 22 March 1942.<sup>11</sup>

One of the South African students on the AQ Wing (Capt Fitz, a pilot) held the Military Medal from 1918. This is remarkable, when one considers that two of the Australians, General Sir John Wilton and Lt-Gen. Sir Thomas Daly, were on Active Service during the Vietnam War. As far as decorations are concerned, many of the 6th Course Haifa students had DSOs, MCs or MBEs — and in many ways know more about the latest fighting techniques (especially armour) that did the Directing Staff.

The following is the background to the photograph of the AIF/NZEF AQ Wing accompanying this article. The full story of the highly interesting Haifa Staff College in general, and 6th course in particular, will be written at a later date. A detailed account of one of the Haifa students, my late father John Lindsay, MC, can be found in *Sabretache*, Jul/Sep 1981; Oct/Dec 1981 'A Gentleman's War', and Orders and Medals Research Society Journal, Spring 1983.

T/Major (rank at Haifa) John Miller Rodd. Born 24 Nov. 1911, Camberwell, Vic. Before secondment to Haifa, 2/14 Aust. Inf. Bn. After Haifa, appointed Liaison Officer, HQ 7 Aust. Division. Mentioned in Despatches. Major, CBE 1968. Consul-General for Sweden in Melbourne. Educated at Scotch College and Melbourne University. Barrister and Solicitor. Director of several companies. Believed deceased, circa 1974.<sup>12</sup>

Major Geoffrey Neil Godsall. Born 26 Nov. 1916. Graduated RMC Duntroon 13 Dec. 1938. Before Haifa, Adjutant 2/16 Aust. Inf. Bn. After Haifa, Instructor, Combined Training Centre. Mentioned in Despatches. Retired 30 Mar 1946, Lt-Colonel. Then Joint Intelligence Organization from which he retired in the early 1970s to live in Surfers Paradise. Died circa 1981-82.

Capt Thomas William Young. Born 19 Dec 1913. Graduated RMC Duntroon 11 Dec 1939. Before Haifa, Adjutant 2/32 Aust. Inf. Bn in Tobruk. After Haifa, Staff Capt 20 Inf Bde at Alamein. Various staff appointments. Instructor, RMC Duntroon. Post-war staff and command appointments. Services Attaché, Indonesia; Military Secretary. Retired 1968; Brigadier, OBE, Executive Officer of Legacy, Sydney.

Capt Ewen Daniel Mackinnon, BA (Oxon). Born 11 Feb 1903, Melbourne, Vic. Educated Geelong Grammar and New College, Oxford. 7 Aust. Division. After Haifa on Gen. Gordon Bennett's staff, Perth, WA. Major 1944, 7 Vic. Bn Volunteer Defence Corps. MHR for Wannon, Vic. (1949-51); for Corangamite

(1953–66). Grazier. Son of the late Hon. Donald Mackinnon, Melbourne. E.D. 'Dan' Mackinnon appointed Australian Ambassador to the Argentine (1967–70) and to Peru and Uruguay (1968–70). CBE 1966. Died June 1983.<sup>13</sup>

Major Roy Russell Gordon. Born 13 Mar 1907. Educated Melbourne University. Before Haifa, 2/3 Aust. MG Bn. After Haifa, Instructor Junior Staff School, First Aust. Army. CO 2/3 Aust. MG Bn 1944–45 (DS). Major-General, AM (1981), CBE (1958), DSO, ED, psc, B.Comm., AASA. Chairman of Services Canteen Trust Fund since 1977; Member Court of Directors, Royal Human Society and many other Trusts and Associations. General officer Commanding 3 Division AMF, 1960–63.<sup>14</sup>

Capt Athol Keith Blaubaum. Born 31 Feb 1908. Mentioned in Despatches (1941). Before Haifa DAQMG (Learner) HQ 9 Aust. Division. Tobruk. After Haifa, attached 'Q' Branch, HQ 4 Aust. Div., Western Command. Reserve of Officers (3 MD) 9 Dec. 1944. Prudential Insurance. Pastoralist.

Major Alan Patrick Bennett. Born 27 Feb 1909. Before Haifa, 2/5 Aust. Inf. Bn. After Haifa, DAQMG 'A' and 'Q' Branches, HQ Second Aust. Army. Lt-Col. 26 April 1943. Reserve of Officers (3 MD) 2 Nov 1945. Melbourne Solicitor. Deceased.

Capt John George Lindsay, MC. Born 14 Jan 1908, Wollongong, NSW. Mentioned in Despatches (1941, Wado Derna). Military Cross (1941, Greece and Crete). Before Haifa, Adjutant, 2/4 Aust. Inf. Bn. After Haifa, Major; Instructor First Aust. Army Junior Staff School and other staff appointments. 1943 New Guinea. 1944 GS02 (Operations) HQ 7 Aust. Div. 1945 Liaison Officer in UK and France. Reserve of Officers (2 MD) 7 Feb 1946. Bank Manager. Died 21 Dec 1975.

Capt Allan David Copeland. NZEF. Mentioned in Despatches. Wounded in action, Italy. Lt-Col. ED. Solicitor. The Auckland Coroner for thirty years.

Major Benjamin Barrington. NZEF. Mentioned in Despatches twice. Brigadier. DSO, OBE, ED. Died 11 May 1954.

Capt Ernest James Horwood. NZEF. Mentioned in Despatches. Regular officer. Major.

It can be seen that the AIF officers were mature—elderly in fact. However, they had seen much active service and had distinguished themselves in many cases.

Staff Schools were really not what we wanted at that time. We were mostly combatant soldiers and just long to get back to our units. We didn't realise, those of us who were non-regulars, that the best way of achieving that object was to fail.

The same officer who wrote that, remembered

'Capt Lindsay when we were allotted to the same syndicate for study, as a quiet, rather studious man, who only spoke when he thought he had something worthwhile to say. I believe he suf-

fered, as we all did, with what Rob Vial<sup>16</sup> described as a strong fear that [he] would not pass.'<sup>17</sup>

It is interesting to note that the AQ Wing Chief Instructor's comment on this.

May I finish on a serious note. I would not have been able to place your father as a name only, but, with the photo, I most surely do remember him as a very high grade officer. There was never the slightest suggestion of his not passing the course. I know that we recommended him for a second grade staff appointment to the Australian authorities. He had no further say than that. With the British, we actually used to go to Cairo and fit people into the jobs available. Whatever your father got, I am sure that he did it well but with no fuss.<sup>18</sup>

These appointments were indeed handled very carefully in the AIF — and at top level.

There is no word of AIF postings, though I understand (Lt-Gen Sir Leslie) Morshead took away the list of gradings and made the recommendations which had to be referred to Australia.<sup>19</sup>

Several high-ranking officers visited to lecture, including the Commander-in-Chief, General Sir Claude Auchinleck, who came on 27 March 1942. Auchinleck 'spoke, and impressed everyone'.<sup>20</sup>

My father gave a lecture on 1 Apr 1942. One of the South Africans on the 'G' Wing noted in this diary '12-1. Capt Lindsay on CRETE'.<sup>21</sup> As he had taken part in the Heraklion battle and the evacuation, this would have been fresh in his mind. Furthermore, this lecture was preceded by Lt-Col Myers, then Commander Fearn, RN, both speaking on 'Seaborne Operations', which would have had a bearing on the Crete talk. In fact, another South African remembered this lecture, forty-four years later: "I can still remember your father's thrilling lecture on the 'Fall of Crete'. I can still see the gliders and the parachutists and the Stukas, just as he described them."<sup>22</sup>

This was not the only lecture that was well-received. Capt James Watt, one of the Australians on the 'G' Wing recalled the talk given by Lieut. J.M.C. ('Jimmie') Wicks, of the Hampshire Regiment (Killed in Action, 1944). 'He had been the DAQMG, Malta, at the time when the forces at Malta were very nearly out of food, fuel and ammunition. Just before he left to attend the course a re-supply convoy from Gibraltar had managed to get through to Malta but suffered very heavy losses. He told us all about the arrangements for the convoy and then give us details of the actual voyage. It was a magnificent talk and I remember that when he finished there was dead silence for some time before the applause broke out.'<sup>23</sup>

Royalty also visited the College. On 17 May 1942, Henry, Duke of Gloucester, attended the cocktail party which marked the end of the course.

'HRH appeared at our cocktail party, sitting aside with the Commandant and a few high officials and his suite. We had another glimpse of him at 8.40 this morning, as he went up the stairs to breakfast...'<sup>24</sup>

There was also some good-natured rivalry, which was only natural among so many different nationalities and Arms. One of the South Africans on the 'AQ' Wing, wrote: 'I do recall standing in one of the picture windows with a bunch of students, some English, some Aussies. drinking our morning tea and looking out to sea at the shipping. One of the officers remarked, 'Look at those feluccas', to which another replied, 'those are not feluccas, they are caiques'. Up spoke an English officer, 'Caiques? I thought that was the Australian for cake'.<sup>25</sup>

I have not touched upon the day to day routine of the staff course. The succession of lectures, demon-

strations, discussions, visits to installations, exercises, telephone battles and so forth.

Many of the DS and the students had impressive records of service, with higher temporary rank, in the Western Desert, the Abyssinian campaign, Greece and even Norway. Many did very well subsequently; a few ended tragically.<sup>26</sup>

The Commandant, Brigadier Dibb, held the next course, No. 7, before receiving the appointment of Deputy Chief of the General Staff, Middle East. For some reason he only lasted twelve days in this appointment, and was sent back to the UK as 'Brig. RA, N. Command'. He became an ADC to the King in 1946, before retirement in 1948 with the rank of Hon. Brig. Apart from his First War decorations, he was awarded the CBE in Jul 1941 and Mentioned in Despatches on 24 Jun 1943. Brigadier Dibb died on 16 Jan 1967. Perhaps rather shabbily treated by the powers that be, he was a considerate Commandant.<sup>27</sup>

#### ENDNOTES:

1. Some notes made in 1958 by Brigadier H.R.H. Greenfield, CBE; Commandant Haifa Staff College 1943-44.
2. Indian Army List, Jul 1939. Major Jim Nelson late RA, has given me an anecdote about 'Derry' Dibb, from this time. 'He was known to me about 1941 as CO of a Field Regt in Kirkee near Poona. He was bald as a coot and on arrival had the Regt formed up in the square and he himself climbed onto the back of a lorry and addressed the unit. "I am Lt-Col. Dibb, your new CO, so now you all know what I look like with my hat on (then he took it off), and how I look without it!" Grand chap.' Letter from Major Nelson to the author 14 Feb 1989.
3. Group Captain Brian Yarde was the Chief Instructor for the RAF Wing. At the beginning he was obliged to carry on single-handedly, until Squadron Leader Paul Cotton, DFC (Missing in Action, 1943) arrived. Yarde played an important part in the Berlin Airlift and became an Air Vice Marshal, CVO, CBE. Died on 29 Oct 1986, at the age of 81. Other DS worthy of mention are Lt-Col Bill Kaulback (later DSO), Douglas Pringle (Brigadier, OBE), John Kempthorne (ED; an NZEF officer), Ralph Littlehales (Colonel, OBE), 'Gerry' Duke (Maj-Gen Sir Gerald, KBE, CB, DSO), the late Dick Batten (Maj-Gen, CB, CBE, DSO), the late George Baker, MC (Field Marshal Sir Geoffrey, GCB, CMG, CBE, MC), Pat Turpin (Maj-Gen CB, OBE), Adrian Hope (Maj-Gen, CB, CBE), Peter Huthwaite, Col. A.C.F. Jackson (Brigadier, CVO, CBE) and the late Jock Sorel-Cameron (Brig, CBE, DSO, DL).
4. Manuscript, 'The War — Part 3 — Staff College Haifa', and letter of 10 Apr 1986 to the author; both written by Brig A.C.G. Jackson, CVO, CBE.
5. Letter from Brig Sorel-Cameron to the author, 3 Feb 1986.
6. Manuscript, Brig. Jackson.
7. Letter from Lt-Col. Philip Parbury to the author, 1 May 1984.
8. Letter from Maj-Gen Roy Gordon to the author, 14 May 1984.
9. Letter from Brig. Young to the author, 31 Aug 1984.
10. Letter from Maj-Gen Roy Gordon to the author, 14 Jul 1984.
11. 'Word from John' (1944). Written by the late John Bishop (Maj-Gen DSO, OBE, ED). Copies sent to the author by Gen Bishop, with a letter, 30 Apr 1984. Some students explored the flesh-pots of Beirut, others went as far afield as Baghdad (Rodd, Lindsay and others). Another group was snow-bound, after skiing in Lebanon, and arrived back late at the College.
12. 'Who's Who in Australia, 1974'.
13. 'Who's Who in Australia, 1977'.
14. 'Who's Who in Australia, 1983'.
15. Letter from Maj-Gen Bishop to the author, 30 Apr 1984.
16. Letter from Brigadier Robert Vial, DSO, ED to the author, 4 Feb 1984.
17. Letter from Maj-Gen Bishop to the author, 30 Apr 1984.
18. Letter from Brig Jackson to the author, 10 Apr 1986.
19. Manuscript of Haifa diary, Maj-Gen Ronald McNicoll, AM, CBE.
20. Op. cit.
21. Haifa diary, the late Major H.J. 'Chappie' Chapman, MBE, LLD.
22. Letter from Capt Trevor Stead (since deceased) to the author 15 May 1986.
23. Letter from Maj James Watt, OBE, ED to the author, 10 Aug 1984.
24. Manuscript of Haifa diary, Maj-Gen Ronald McNicoll, AM, CBE.
25. Letter from Lt-Col. A.C. 'Pat' Leary, ED, despatches (since deceased) to the author, 21 Sep 1986.
26. Notably Capt George Webb, MBE, of the Royal Tank Regt. Undoubtedly the most brilliant of the students on the 'AQ' Wing, always willing to help less knowledgeable students, George Webb came through the ranks pre-war and then to Sandhurst. He was also an outstanding athlete. By 1944 he was a Brigadier, CBE, DSO, but in Apr '45 was killed when his jeep hit a tree.
27. 'Brigadier Dibb wrote to my parents after my capture, sympathised with them and cheered them up by saying that he had given me a good recommendation.' Letter from Capt Trevor Stead to the author, 4 Jul 1986.

John S. Fenby

## North Head Barracks, Sydney

*This paper presents a condensed history on the Barracks and other buildings at North Head, Sydney*

**P**rior to 1934–35, North Head and its immediate surroundings belonged to the Marine Quarantine Station. A sandstone wall was in place in November 1914, between Collins Flat Beach, to the cliff face between Cabbage Tree Bay and North Point, enclosing an area of approximately 658 acres.

In May, 1927 the area was opened to the public for the first time to coincide with a visit from the Prince of Wales. Soon afterwards a Memorial Drive was constructed around North Head, with a tree planted for every soldier from the Manly-Warringah area killed in World War One. The sandstone wall didn't stop the local children from entering the area to catch tadpoles in the swamp, in an area now occupied by the Parade Ground at North Head Barracks.

North Head was proclaimed a Defence Area in the Commonwealth Gazette, No. 100, dated 26 September, 1927, which states:

### PARISH OF MANLY COVE

All that piece of land near Manly, containing an area of 658 acres, more or less, being the Marine Quarantine area. Proclaimed under section 124 of the Defence Act 1903–1927.

It was declared a prohibited area in November 1932, along with Fort Scratchley, Fort Wallace, Middle Head, and Inner South Head.

North Head was proclaimed a prohibited place for the purpose of National Security Regulations, on the 21st March, 1940, this proclamation was to remain in force until the 3rd December, 1947.

With the installation of the 9.2 inch guns at North Head, Barracks were needed to house the gunners on the guns and No. 1 Heavy Brigade, Royal Australian Artillery. This then was when the controversy started, over the plans and costs, involved in the building of the barracks and other buildings.

The plan called for the building of a barrack block, garage, gymnasium, officer's mess, married quarters, workshop, dry canteen, administration building and a sports ground.

In 1936–37 the total approved for the construction of the Barracks and other buildings was £111 000, this was in 1937. In February 1938 an additional £47 000 was allocated. The lowest tender was £168 000. In a Department of Defence Minute Paper, on Defence Works and buildings — question of economy in execution of: dated 19 January, 1938, the then Minister made the following comments:

... On that Friday, he and Mr F.G. Shedden visited North Head, Middle Head, Chowder Bay and Georges Heights. We inspected the new Batteries at North Head, which impressed me as a very satisfactory piece of work. We then proceeded to the new new Barracks where I was astonished to discover the elaborate nature of the buildings, in the course of construction and upon examination of the plans, I found that a tremendous amount of money was being spent on unnecessary extensive buildings which, if completed, would not satisfactorily meet the requirements of the Garrison. For instance the Barracks are designed to provide accommodation for about 300 single men, and upon making enquiries I was informed that about 60 per cent of the men are married. The plans also provide for a large recreation hall (later to become the Ballroom) above the Dining Hall, necessitating the use of eight to ten, twenty-four by seven and a half inch steel girders over fifty feet long, and a most expensive type of steel roofing.

The Plans also provide for a most expensive reinforced concrete flat roof and cantilever balcony roof. This would be unsuitable because of the heat and the cost could not be justified particularly in view of the fact that the bedroom wings are only one room deep, and the balconies are twelve feet wide, with a ten-foot cantilever concrete roof unsupported and carrying an upper handrail to enable the flat roof to be used by the men.

The building at the entrance to the barracks is also of a most expensive type and I consider it unsuited for the purpose for which it is intended.

No consideration was given to the ground plan and the fall of the land, with the result that the long narrow building is running with the slope of the hill, necessitating very deep foundations which have not been utilised.

I also noted the fact that the large useless entrance gateway is constructed mostly of specially moulded bricks, the cost of which was apparently ignored.

The whole of this building carries a three-foot parapet wall, extensive copper box gutters, the whole of which had to be flashed and damp-coursed at a very considerable cost, all of which could have been obviated by allowing the rafters to continue and form a small eave with a fibro-cement gutter. A considerable amount of copper downpiping could also have been eliminated by the use of fibro-cement. The same can be said of the unnecessary expense associated with the construction of the cells and exercise yard with over-hanging concrete slabs.

An examination of the earth works associated with the construction of the Parade Ground, is a further indication that cost was not taken into consideration when these plans were drawn up and if it were not for the fact that some of the buildings are already completed, and others well under way, I would have definitely cancelled the whole of the plans and specifications.

On my arrival in Melbourne, I examined the plans and found that several other building, including the officers' mess, gymnasium, sergeants' mess etc., are designed on a most elaborate and extravagant scale, with unnecessary parapet walls and expensive foundations, much of which could have been avoided.

After a careful examination of the whole scheme, the amount of money already spent and the cost to complete the works, I have come to the conclusion that the whole of the plans and specifications must be immediately revised, all parapet walls and box gutters be deleted, the flat concrete roofs replaced with corrugated fibro-cement hip roofs, including the cantilever roofs, and that the eastern wings of the barracks be confined to one storey instead of two.

Particular attention is directed to the costly set of motor garages and other foundations at the officers' mess which appears to be a most expensive layout. . .

In a memorandum issued by Mr F.G. Shedden, after a telephone conversation to the Director-General of Works, concerning alterations to the barracks area, as desired by the Minister for Defence, the following points were raised. . .

#### **Barrack Block:**

Flat concrete roof to be deleted and replaced by

a hip roof with fibro-cement sheeting.

#### **Gymnasium:**

If grading has not already been completed, the building is to be turned at right angles to its present location.

#### **Officers' Mess:**

Concrete verandah over patio to be eliminated.  
Garage roof to be hip type without parapet wall.  
Car park roof to be omitted.

#### **Married Quarters:**

All married quarters still to be built, i.e. four NCO's quarters, one Quarantine quarter and one Officer's quarters to be redesigned to conform to the following principles. The outside trace of the buildings to be as simple as possible, and the number of returns of walls to be reduced to a minimum, thus simplifying roofs and construction generally unless required for structural purposes, all partition walls are to be four and a half inches instead of nine inches brickwork; bathrooms, kitchens, lavatories and laundries to be placed as close as possible to reduce the cost of sewerage and other services involved; where repetition buildings are involved such as the four NCO's quarters, the design is to be the same, variety being obtained by varying the setting up of the buildings and by simple alteration of outside brick courses, all outside ornamentation, to be reduced to a minimum.

#### **Proposed Garage and Workshop, Dry Canteen and Trades Building:**

To be redesigned in accordance with the remarks under general below. Inside partition walls to be four and a half inches brickwork instead of nine inches except where the latter is required for structural purposes.

#### **General:**

All flat concrete roofs and parapet walls are to be eliminated in new construction and if possible in those under construction. . .

It is interesting to note that there was no mention made of the parquet floor in the Recreation Hall or of the two carved wooden doors at the entrance to the Barrack Block, maybe these came at a later date.

In a note to the Minister, dated 24th January 1938, the following comments were raised. . .

It is most desirable that the Barrack Block be completed for 300 men, for the following reasons:

1. It is essential for efficiency that all RAA recruits be trained at one centre and North Head will become the training depot for RAA, for all stations in Australia, except for WA. This will mean a very large percentage of single men on the station.
2. North Head will in addition to (1) accommodate in peace time the majority of RAA personnel to man the Coast Defences of Sydney, and

the Anti-aircraft cadres for Sydney, Newcastle and Darwin (temporarily whilst in training).

- By 1940 under existing programme proposals, there will be 394 RAA personnel in Sydney alone not counting recruits under training from other districts. These latter may be estimated to rise as high as fifty, for periods of six months at a time giving a total of approximately 450.

After deducting all Senior WOs and NCOs, 50 per cent of Junior NCOs and all District gunners as married (totalling 100), and 25 per cent of gunners (88) it leaves 262 single gunners to be accommodated, plus about 20 RAE personnel; grand total 282. A few RAA personnel will be distributed at out-stations, say 12, leaving 270 at North Head.

- In order to obtain full efficiency from the new defences installed in Sydney, it is necessary under later programmes to increase the number of RAA personnel (by about 50 to provide for all key appointments being filled by members of the Permanent Forces).
- If the Minister considers it essential to reduce the building programme at North Head at the present time, it would be better to cut out the block of Battery Administrative buildings, rather than to reduce the accommodation for the barrack block which will have to be built to take 300 men within the next few years. . .

In a report on Defence Works progress on North Head, the dates for completion of the various projects were as follows:

**Laying of Sports Ground:**

Completed on the 6th February, 1939 but could not be used until planted grass has fully covered the area.

**Garage, Workshops, Canteen and Gymnasium:**

Should be completed by the 20th February, 1939.

**Officers' Mess:**

Should be completed by the 20th February, 1939, approach from Parade Ground paths and steps not completed but should not interfere with the occupation of the Mess.

**Six Married Quarters:**

Completed on the 6th February, 1939.

**Works for site of Barracks and Administrative Offices:**

Completed on the 6th February, 1939.

**Barracks and Quarters:**

Should be completed by the 20th February, 1939 and should be ready for handing over, including all furniture.

In 1938, the training of Artillery Officers was carried out at North Head Artillery School. Training of Artillery recruits at North Head commenced in 1939. In February, 1940 the following units were located at North Head:

HQ NSW Lines of Communication area,  
115 Heavy Battery, and  
2 Garrison Company, AAMC.

HQ Sydney Fortress was located at North Head and was comprised of the following units:

HQ NSW Lines of Communication area.  
Fixed Defences, Heavy Artillery.  
Sydney Fixed Defences, Artillery.  
HQ Close Defence Conditions.  
Fire Command and Fortress Section.  
Two Radar detachments.  
No. 1 Coy, Fortress Signallers.

An RAAF Communications section that was used to engage targets, using aircraft spotters.

Two 40mm Bofor, anti-aircraft guns, later increased to three. Of 154 LAA Regiment RAA (believed to be 9AA Battery RAA).

One problem experienced with North Head, was a shortage of water. In a Fixed Defences, Routine Order signed by Brigadier J.S. Whitelaw, CBE, it was stated that the use of water was totally prohibited, except between 6am-10am and 4pm-8pm, baths being limited to four inches of water and car washing banned, except by bucket and mop. Some relief would have been in a natural spring at North Fort, which was believed to start at Manly Dam, and followed a natural fault in the sandstone to North Fort.

The problem was so bad that a pump was installed in the No. 2 gun, lower shell store, in the anti-blast recess. On one day 40 000 gallons was pumped out and pumped back to the Barracks, this would have helped to relieve the water restriction (the pumping shed still stands today at the Eastern end of the Barracks).

Other dates associated with the Barracks are:

- Anti-aircraft 40mm Bofors and personnel, marched out from Nore Battery on the 7th April, 1943.
- Brigadier A.M. Forbes assumed command of Sydney Fortress, on the 3rd May, 1943.
- 1 Australian Radar detachment, departed North Head on the 1st April, 1945.
- 7 Australian Radar detachment, departed North Head on the 3rd April, 1945.
- On the 5th May, 1945, advice was received from HQ Second Aust. Army, that LHQ School of Artillery would occupy North Heads Barracks.
- On the 13th June, 1945, the advance party LHQ School of Artillery (Coast) marched into North Head Barracks.
- On the 18th June, 1945, personnel of LHQ School of Artillery (Coast) were located at North Head Barracks.
- On the 30th June, 1945, HQ Fixed Defences NSW and HQ Sydney Coast Artillery, closed at North Head and reopened at South Head, LHQ School of Artillery (Coast), premises.



The Dry Canteen was later to become the "Q" Store. A new Other Ranks Canteen was being built, and was named after Lt. R. Cutler, VC, now Sir Roden Cutler, VC.

One interesting aspect of North Head, is the myth about miles of underground tunnels and an underground hospital, the only ones that I could find, or find any evidence of were:

1. The tunnels at the Gun positions, leading from the Engine Room to the two Guns at North Fort.
2. A tunnel, from the Battery Observation Post to a Machine Gun post.
3. An escape tunnel, leading out of the Battery Plotting Room.
4. A strong room at the southern end of the administration block now covered over.
5. A Switchboard room, under the Guard Room.
6. A submarine cable, from Old Man's Hat to South Head.
7. But I believe the greatest myth of all and told to all new recruits is of a hospital under the parade ground, of which I have never been able to find any evidence, and considering it used to be a swamp, the engineering problems would have been enormous and costly, which I doubt would have been approved by the government of the day.

The barracks are today still occupied by the School of Artillery, where courses are conducted covering all aspects of artillery training and traditions.

The present school can trace its origin to the New South Wales, School of Gunnery, which was established at Middle Head in September, 1885, under the command of Col. E.G.H. Bingham, RA. The first class entered the school on the 10th May, 1886, and departed on the 14th July, 1886.

The school conducted a variety of courses in both coast and field artillery from 1885 to 1893, when it was moved to Victoria Barracks, Paddington.

The move to Victoria Barracks, was only a temporary one, pending the completion of the new school buildings and facilities, at South Head. On the 22nd of July 1895, the school moved to South Head.

The school remained at South Head until the outbreak of World War II, in September 1939. The with the outbreak of the war, the establishment of the school was greatly increased to meet the needs of the enlarged Military Forces therefore wings of the school were established at Randwick and Holsworthy. In 1946 the wings were again combined and located at North Head. Where they remain today.

#### ENDNOTES:

1. Memoir of North Head Fortifications. J.S. Fenby.
2. Australian Archives, Canberra. CRS A664 and MP1217. Reproduced and published with the permission of the Australian Government.
3. Royal Regiment of Australian Artillery, Brochure. Reproduced and published with the permission of the Commanding Officer, School of Artillery, RAA.

Paul Rosenzweig

## The 121st Australian General Hospital, AIF Katherine, 1942–43

The 121st Australian General Hospital was one of the 'Top End's' vital facilities during WWII but due to its remote location little detail has been recorded on it. Indeed it was unusual in the fact that its members qualified for AIF status but never left Australian shores, most of them serving at Katherine some 300km inland. Here the hospital enjoyed relative safety, far from the Pacific war, only once tasting the enemy's fury — during the sole raid on Katherine on March 22nd 1942 which resulted in one dead and one wounded in the town. In memory of this event the staff of the 121st AGH erected a simple stone monument bearing the brief inscription "22-3-42, 121 AGH, AUSTRALIA" on the outskirts of the hospital grounds.

### The phoney war

Despite the vital strategic importance of Darwin in early 1940, the 'Top End' still did not have any form of military medical facility, relying instead upon the civilian hospital. This situation was eased somewhat in July with the arrival of a detachment of the 2/5th Australian General Hospital under Captain Brooke Moore, establishing themselves in the Bagot Aboriginal Reserve. By the end of the year Bagot possessed a 150-bed hospital, opened on December 19th at the 19th AGH, with Major N.W. Markwell as the Senior Medical Officer.

Capital Brooke Moore's medics then departed for the tropics to rejoin the 2/5th AGH in the equally warm but rather more pleasant (although more hostile) environs of the Middle-East.

In early April 1941 Colonel E. Culpin opened the 119th AGH at Bagot, a 1200-bed hospital which had been built to replace the 19th AGH. In January the Headquarters of the 119th was transferred out of town to Berrimah where a 600-bed hospital had specially been built, while an inland wing was established at Adelaide River under Lieutenant-Colonel W.J.S. Ingram. He was a distinguished medical officer with an impressive record. He had won the Military Cross during the retreat from Mons, and in 1929–1931 served on two successive Antarctic research expeditions with Sir Douglas Mawson, earning the Polar Medal with two bars, while as a doctor he was a well-respected consulting physician from the Royal North Shore Hospital.

The 119th had a rather more 'exciting' time than the 121st — notably being machine-gunned by the Japanese during an air raid. Details of the 119th's service in the Northern Territory have been recorded by its Matron, and later Principal Matron of the Northern Territory, Edith McQuade-White,<sup>1</sup> and Surgeon Pat Pavy.<sup>2</sup>

This period in the Northern Territory prior to the bombings 'was almost like a peace-time posting except that there were a lot more service personnel around,' recalls Arthur Kennedy, then a member of the anti-aircraft artillery recently arrived from Sydney. 'We were able to go on trips down country — weekends were off unless one was on duty' although 'most single women in town would not look at you unless you were either a bank clerk or had a commission.<sup>3</sup> In contrast, Sister Mary O'Hanlon recalls that in the two following years, the nurses were almost the only females remaining in the Territory, which ensured that 'there were no nurse "wall-flowers" at the well attended dances in the mess hall'.<sup>4</sup>

There was a good deal of discontent in the Territory during this 'phoney war' stage, particularly as service there did not qualify for AIF status, even after the raids had commenced and the element of danger had increased substantially. Later in 1942 this service was recognised and 'Australia' titles were worn by personnel of those units upgraded to AIF status. The other benefit was eligibility for the Defence Medal after three years' service, and many of the orderlies, drivers and stretcher-bearers earned this medal to complete a threesome with the War Medal 1939–45 and the Australian Service Medal.

### The influx of casualties

In January 1942 with the increased military activity in the Pacific theatre, and the overwhelming influx of refugees and wounded from Malaya and the Netherlands East-Indies, it was deemed necessary to open another hospital at Katherine, the 121st AGH. Initially a 600-bed hospital, it was later upgraded to 1200 beds, and was a vital facility in coping with the flow of wounded from the north.

The advance party to establish the 121st arrived at the Katherine River during May 1942; amongst them was Peter Langsford as NCO in charge of medical and



Headstone of Sister Marion Watt Eunson, Australian Army Nursing Service, of the 121st AGH, AIF. Killed on December 8th 1942 aged 26, she was the daughter of John James Ronaldson and Mary Oliphant Eunson of Coburg, Victoria.



Memorial to the bombing of Katherine on March 22 1942 which was constructed by members of the 121st AGH. It now stands in a small garden at the front of Norwest Meat Works.

surgical supplies in the hospital's pharmacy. During his stay in the Northern Territory he assisted the unit's two pharmacists, Staff-Sergeant (later Lieutenant) Hardy and Sergeant (later Staff-Sergeant) McReady, while he also spent a vast amount of time despatching supplies to the numerous smaller establishments including Casualty Clearing Stations, Regimental Aid Posts and Camp Hospitals scattered between Larimah and Darwin.<sup>5</sup>

In June 1942 Sapper Frank Cridland was hospitalised at the 121st suffering from yellow jaundice, having only recently arrived in the Territory to work on the all-weather road between Katherine and Larimah. Together with 31 of his colleagues he was admitted to the AGH: 'I heard that four died. I know that the rest of us were pretty damned sick on the Very Seriously Ill list.' Towards the end of 1942 his unit returned to Kapooka to refit for island service, finishing up in Borneo in 1945. 'I wasn't with my mates,' he recalled:

'because prior to their departure up north again the medics downgraded me to A2, unfit for tropical service . . . What with the effects of tropical skin ulcers, duodenal ulcers, cured then relapsed three times, rosacea, amoebic dysentery, etc., etc., the remainder of my Army career until discharge in November 1945 was not fraught with much danger from shot or shell.'<sup>6</sup>

Sister Mary O'Hanlon of the 121st recalls that by far the majority of patients were military:

'Civilians had long been evacuated. The occasional tin miner and labour corps personnel arrived for treatment. Timor escapees with tropical sores. . .'<sup>7</sup>

The 121st was a welcome blessing for the local Aboriginals who were pleased to receive some long overdue attention.

Families always accompanied and stayed with Aborigine patients in the 'compound', squatting in tent door ways, feeding and in many other ways looking after him.<sup>8</sup>

Sapper Irving of the 20th Field Company, Royal Australian Engineers, recalls his experiences with diphtheria:

Anyone who wanted to go on sick parade was taken on the ration truck to 121AGH. . . The isolation ward was a square American tent with an anthill floor. . . After four weeks' isolation I was moved to a general ward, a tin shed with a steel frame known as a Sydney Williams hut. There was an Aboriginal patient with malaria known as "Buddy". As soon as Buddy felt a little better he went bush and we didn't see him again for several days. By that time he really did look very ill.'

Some days after I was admitted another patient joined us, Tom Forrest, a fisherman from Port Lincoln, SA. I recognised him as the hitch-hiker

we picked up on the way in from Manbulloo Station. . .

After six weeks at 121 I was sent to the Convalescent Camp at Burrundi. I travelled there with another member of the 20th, Sapper John Flarvin. When the tram arrived at Katherine railway station it was already overcrowded and we had to travel in a goods truck on a load of burnt logs. We left Katherine at about 9 pm clad only in shirt, shorts, boots and sox. By midnight it was really cold in that steel truck. At daylight in Pine Creek we looked like a couple of chimney-sweepers.

We reach Burrundi in time for a midday meal but had to wait until 9 pm for the showers to be cool enough to use. I was in Burrundi Convalescent Camp for three weeks. It had one thing going for it, sugar. It was the only place in the NT where I had tea with sugar.

At Burrundi they used to march us two miles to a billabong for a swim. One day a fellow with a heart condition said he didn't think he'd make it — he was right. He was alive when they put him in the ambulance and we hoped he'd be OK. I wonder what was written on his records.<sup>9</sup>

Means of transport varied greatly in the Northern Territory, and in most cases it was a matter of luck whether you travelled in comfort or not. John Egan, in the Territory with the 8th Battalion, had been admitted to the 119th at Adelaide River in mid-1942, but complications necessitated his transfer to the 121st for specialist treatment in their well developed Chest Ward. He recalls that the journey was made by the Hospital Train which at that time had only just started running.<sup>10</sup>

### The ambulance services

The transport of casualties was originally conducted by the 7th Mobile Ambulance Column, a unit which was formed in Sydney and despatched for Darwin in 1940. Every medical unit throughout the Territory had at least one ambulance, and the major centres such as Alice Springs, Tennant Creek and Katherine had three or four each, while there were also some based in such Queensland centres as Camooweal and Mount Isa. It was released in about May 1943 and replaced by the 1st Mobile Ambulance Column.

Meanwhile, the 'Hospital Train' had been created out of cattle trucks of the Northern Territory Railways to cover the transportation of casualties from Adelaide River to the 121st Australian General Hospital at Katherine. It comprised from five to seven carriages, each of which was two bunks high on each side with a central passage-way for the movement of medical staff. Each carriage could carry about forty patients.

It was a most useful innovation for moving large numbers of casualties to the relative safety of the 121st AGH. To have tried to move them by road ambulance would have been most impractical and expensive as

these could only carry four bed patients. For security reasons the train only travelled at night, departing in darkness and arriving at Katherine at about 7 am, from where ambulances would ferry the troops to the hospital.

'I recall the trip as a quite a comfortable one, much in contrast to the same cattle trucks (unconverted) that were used for general troop carrying,' recalled John Egan.<sup>11</sup> His bronchial complaint resolved, his five-day stay was followed by a twenty hour return trip to his unit — a rough, dusty ride in a dark and dank cattle truck with no blankets and no food, and plenty of breakdowns leaving the passengers standing around for hours in the chilled night air while repairs were effected. Little wonder then that the draught and damp should be sufficient to induce a relapse. Being painted as a medical facility with prominent red crosses, the train was of course not available for the return transport of troops after their discharge from the 121st, so a rather unpleasant journey was made in unconverted cattle trucks.

After his call-up in 1941 John Egan had entered Balcombe Military Camp on the Mornington Peninsula in Victoria for six months' training. Just four weeks later they heard of the Japanese attack on Pearl Harbour and were immediately put on 'full-time duty'. They were moved to Dandenong and merged with the 8th Infantry Battalion, and without any further training or issue of equipment found themselves travelling by rail and road. 'No destination was ever given, and only on arrival at Noonamah were we told "This is it!"'<sup>12</sup>

They then moved up to Darwin, and four days later experienced the first Japanese raids. John Egan's party was responsible for patrolling the waterfront at high tide to retrieve any bodies or equipment that might float ashore — a most unsettling introduction to the war. At other times the battalion practiced defensive tactics, guarding key installations. On one occasion they conducted an exercise in securing the Darwin railway sheds only to find that the Japanese had come up with the same facility as the focus for their raid!

John Egan experienced every one of the Japanese raids on Darwin and environs, serving with both the 8th Battalion and the 1st Mobile Ambulance Column. He recalls one night raid when three bombs were dropped in the middle of their camp — the tents were dispersed so none of the men were injured, but the ambulances which were lined up barracks-style suffered a good deal of damage. The next morning the drivers were busy practising deployment drills which would minimise damage to the vehicles in the event of another raid.

He recalls that after the commencement of the raids the men had it put to them very bluntly nearly every day — the invasion is coming and you are the blocks that must stop them. In hindsight, he now replies 'With what?' He returned to Darwin in June 1987, driving from Alice Springs, and could feel

nothing but admiration for the road engineers who had constructed the first highway to the north. In town he saw a great contrast — during the war there were only a few service personnel in Darwin but the bush was teeming with bodies, while today it is the opposite.

He was easily able to locate four old campsites, readily distinguishable by the first thing that is done when establishing a camp — the concrete slab. The 1st Mobile Ambulance Column had laid such slabs as floors for workshops which were always busy servicing and repairing the ambulances. One camp now has the new highway running straight through it, and another of their camps is now part of the Darwin Showgrounds, being in those days Winellie Army Camp. The 1st MAC remained in Darwin until January 1946 when it was disbanded.

### Life in the tropics

The 121st was sited alongside the Katherine River on the outskirts of the Katherine township. Surgeon Pat Pavy of the 119th AGH recalls a visit to the 121st in mid-1942:

'I had been driven from Darwin to Katherine to attend a clinical meeting at 121 AGH. This was the roughest track I have ever travelled, including those of the South-East in the early days. To me it was an amazing thing that a motor car could negotiate such difficulties . . . at times it was most difficult to stay in the car at all, let alone stay on the seat.'<sup>13</sup>

Sister Mary O'Hanlon joined the 121st in October 1942 from the 115th AGH at Heidelberg, finding life in the north very different to anything previously experienced.

'Found weather so hot and tinned butter rancid, flies accompanying the food to the mouth in the fly-wired mess hall; powdered eggs only — result two stone weight loss in two months.'<sup>14</sup>

The 121st was mostly housed in tents, while several of the wards, operating theatres and offices were offered the protection of galvanised iron sheds on concrete foundations. The tentage was made rather more homely by the unit's nursing sisters in their off-duty hours, surrounding them with carefully tended gardens edged with white stones. When not otherwise engaged the nurses relaxed in 'Palm Court', their private open-space recreation hut.

The hospital was supplied with water provided by a bore sunk by men of the 2/11th Army Troops Company, Royal Australian Engineers. Reaching a depth of about 60 metres, it gave a flow of nearly 7,000 litres per hour which became vital during the dry season. The hard water was not accepted well by the ladies though, who would trek 400 metres to the river to bathe. Life was a little more pleasant once the rains came however:

The blessed deluge of 3" a day for three



*Colonel Geoffrey Penington at his desk whilst commanding the 121st AGH, AIF in Katherine during 1943.*

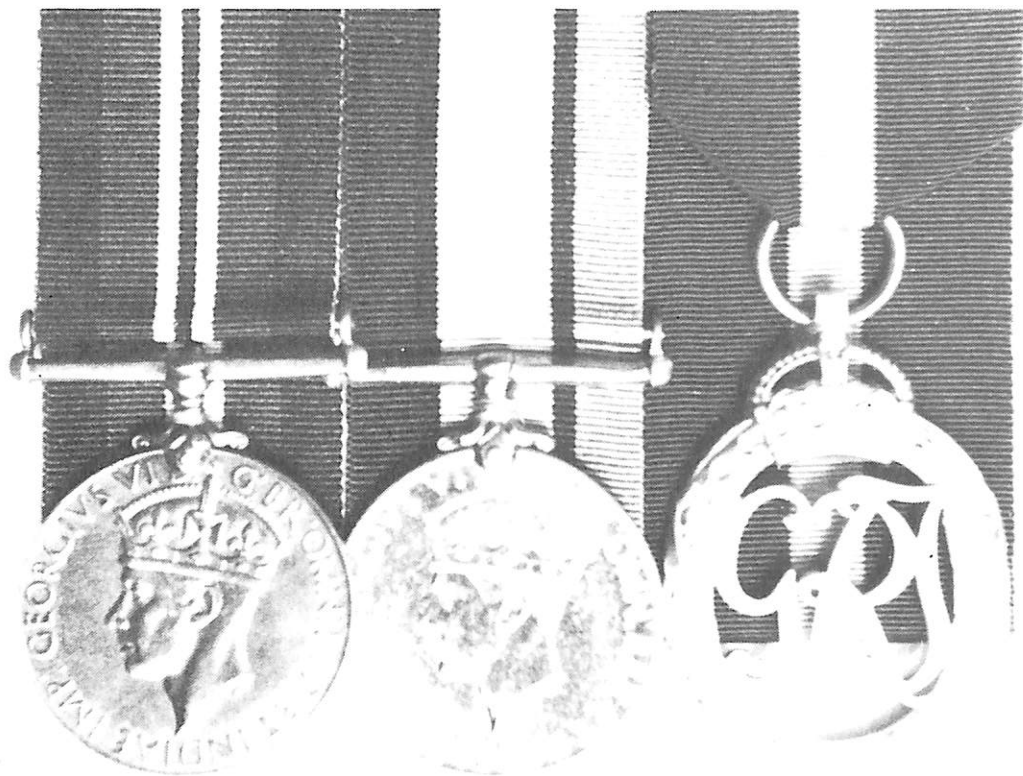

*The medals of Colonel G.A. Penington, ED.*

months in the Wet meant forays in our bathers just to stand outside our living quarters in off-duty hours.<sup>15</sup>

One of the few solaces was the iced tea or cocoa kept in the ward fridges, while culinary needs were tended to by the Chinese cooks in galvanised iron out-houses. There was little respite from the harsh climate:

the hot sun caused our metal shoulder 'pips' to burn our skin. Felt hats were 'de rigueur' — straw was hopeless against penetrating sun which could bleach our summer cotton grey in half an hour.<sup>16</sup>

Sister Marion Eunson, who died on December 8, 1942 aged 26, was the 121st's only casualty during its stay in Katherine. Sister O'Hanlon recalls that, 'like many other patients, the severity of her illness was increased by the humid conditions preceding the relief of the Wet'.<sup>17</sup> The months of October and November, before the relieving December rains, have long been regarded as the worst time of the year in the north. The intense humidity which builds up to saturation levels in the afternoon, 'completely destroyed memory retention for 2 hours . . . Understood at last 'siesta' doesn't mean laziness in Spain'.<sup>18</sup>

But then suddenly the rains come:

those refreshing downpours sometimes three inches in half an hour, the rivers rising 30 feet —covering the bridges and planting cans and debris in the tops of high trees, and growing grass to the height of 15 feet before the end of the season (so that one could literally lose oneself in a hitherto familiar paddock).<sup>19</sup>

### The Commanders

Colonel Arthur Morrow arrived in Katherine on May 14 1942 to assume command of the 121st, having been Commanding Officer of the 119th AGH for the three weeks prior. He saw the hospital through 1942 and in March 1943 was posted as Assistant Director-General of Medical Services at Land Headquarters. He saw the end of the war as consulting physician with Advanced HQ, Australian Military Forces, earning the Distinguished Service Order for this praiseworthy work, as well as being appointed to the rank of Honorary Colonel upon his retirement in December 1945.

Colonel Geoffrey Penington arrived on March 11th 1943 to assume command of the 121st, near the end of his second decade of CMF service. Since his commissioning in 1924 he had served in various medical appointments with cavalry units, notably as the Officer Commanding, 3rd Cavalry Field Ambulance. At the time of his secondment to the AIF he was Honorary Physician at the Royal Melbourne Hospital, a position he had held since 1928. He commanded the 121st for two years, until February 7th 1945, and was responsible for evacuating the hospital to Northfield in Adelaide, in August 1943 as the need for such a

facility in the Territory waned.

Colonel Penington commanded the 114th and 118th AGH's after the war, retiring on July 11th 1946 and returning to the Royal Melbourne. From 1947 he was an Examiner in Medicine and Steward Lecturer in Medicine at the University of Melbourne while from 1959 he was a Consulting Physicial at the Royal Melbourne. His sons also pursued a medical career, one of them being Professor David Penington, Professor of Medicine at Melbourne University since 1970 and more recently, Chairman of the AIDS Task Force.

Within the command structure of the hospital was a Surgical Division and a Medical Division, the former being commanded by Lieutenant-Colonel J.M. Buchanan, whom Austin Woodbury of the North Australia Observer Unit remembers as having a particularly acute sense of humour, especially when it came to the removal of severely infected toenails which had become ingrown during a prolonged horse-mounted patrol.<sup>20</sup> The Medical Division was commanded by Lieutenant-Colonel J.P. Horan, while other officers in the unit included surgeons Bonnin and McElhone, and Captains Johnston (pathologist) and Alps (dermatologist).

### A taste of the Japanese

The opening of the 121st was very timely following the commencement of aerial bombing raids across the north of Australia. To handle the steady flow of casualties the Territory had the 119th AGH, by that time fully based at Adelaide River, and the 121st at Katherine, with a major Casualty Clearing Station at Noonamah some 40km south of Darwin. Kahlin Civil Hospital was being used as a Fortress Hospital in Darwin itself, while the 2/12th Field Ambulance under Lieutenant-Colonel N.D. Barton supported the 23rd Brigade, AIF.

The raids on Darwin became part of the routine, but it was not long before Katherine itself was bombed, a timely reminder that even 300km inland they were not immune from the wrath of the Japanese. In one raid, on March 22 1942, nine planes approached from the north-east and released their bombs. Fortunately casualties were minimal, including one Aboriginal killed outside the Katherine hospital.

The only resident of Katherine today to have witnessed this bombing is Mr Bert Nixon, OAM, now nearing his eightieth birthday, a farmer on the Katherine River for over half a century.<sup>21</sup> He was well known to the military as 'The Tomato King' as he was the sole supplier of fresh vegetables, particularly tomatoes, to the forces in Darwin, from whence they were flown to the islands. He was busy tending to the irrigation of his tomatoes when the raid occurred, and still possesses scraps of iron from the bombs.

There seems to have been little reason for the raid, as casualties and damage could have been far worse had it been effected properly. It would seem that

perhaps the bombers were after a suspected fighter base, or even the Daly Waters strip 200km further south, and simply jettisoned their load to enable them to safely complete the return journey.

The staff of the 121st received another scare in May 1943 when Japanese aircraft penetrated some 130km down the Daly river. Sister Mary O'Hanlon remembers receiving the order 'Prepare to evacuate in a fortnight' — the urgency was heightened with the spotting of two Japanese reconnaissance aircraft flying high above the hospital. The Battle of Midway had turned the tide however, and fears of an invasion ebbed. The decreasing workload saw Colonel Pennington ordered to evacuate the 121st to Northfield in

South Australia in August, although some members stayed on with its replacement, the 101st AGH.

Nothing today remains of the 121st's site alongside the Katherine River, but before they departed the staff constructed a monument with a crudely engraved cement block bearing the inscription "22-3-42, 121 AGH, AUSTRALIA" in recognition of their brush with the enemy, and Katherine's first and only raid by a foreign aggressor.

The block was tidied up by the Katherine RSL in 1964, while in 1966 the hospital site was occupied by Norwest Meat Works who have looked after the monument since that time.<sup>22</sup>

#### ENDNOTES:

1. McQuade-White, *Reminiscences of an Australian Army Nurse*.
2. Pavy (1979).
3. Arthur Kennedy, Pers. Comm., 4 Dec 1986.
4. Mary O'Hanlon, Pers. Comm. 26 Apr 1986.
5. Peter Langsford, Pers. Comm. 28 Apr 1986.
6. Frank Cridland, Pers. Comm. 26 April 1986.
7. Mary O'Hanlon, Op. Cit.
8. Ibid.
9. R.R. Irving, Pers. Comm. 8 Aug 1986.
10. John Egan, Pers. Comm. 1 June 1986.
11. John Egan, Pers. Comm. 21 Jan 1988.
12. Ibid.
13. Pavy (1979) P.151.
14. Mary O'Hanlon, op. cit.
15. Ibid.
16. Ibid.
17. Mary O'Hanlon, Pers. Comm. 6 Oct 1987.
18. Mary O'Hanlon, Pers. Comm. 26 Apr 1986.
19. Mary O'Hanlon, Pers. Comm. 6 Oct 1987.
20. Austin Woodbury, Pers. Comm. 7 June 1986.
21. OAM awarded 26 Jan 1979 for service to agriculture and to the development of primary industry in Katherine. *Commonwealth of Australia Gazette*, S11.
22. Lindsay Phillips, OAM, Pers. Comm. 10 Feb 1986.



*John Haken*

## **Colonel G.C. Somerville C.M.G., D.S.O., M.I.D., C.deG. Staff Officer and Administrator**

**G**eorge Cattell Somerville was born on 13th July, 1877 at Goulburn, New South Wales, the second son and second eldest of five children of John Blakely Somerville and his wife Francis Clare nee Phillips both from Sydney.<sup>1</sup> The father was an employee of the Australian Joint Stock Bank having previously served at the Cooktown Branch. The family moved north from Goulburn and Somerville senior was manager of the sub-branch of the bank at Morpeth from 1880 to 1884 then to Sydney where he established a branch at Summer Hill which opened during July 1885. In 1897 he became manager of the Wooloongabba Branch of the Royal Bank of Queensland and he remained in this post until 1894 when the branch was closed as a consequence of a banking crisis in 1893 and then became manager of the Ithaca Branch until it also closed in 1899.<sup>2,5</sup>

George Somerville was educated at the Normal School, Brisbane, and at Brisbane Grammar School during 1893 and 1894<sup>6</sup>. Early employment was in the insurance (1895–1897) (Citizens Life Assurance Co. Brisbane)<sup>4,6</sup> and banking industries (1897–1899) (Bank of N.S.W. Brisbane and South Brisbane)<sup>4,6</sup> during which time he passed the Bankers Examination. He moved with the family to a farming property at Millers Forest (near Raymond Terrace) where he remained for six years. The elder brother John Phillips Somerville remained in Brisbane as an employee of the Bank of N.S.W.<sup>3</sup>

Somerville joined the Raymond Terrace-Dungog Squadron of the 4th Light Horse as a trooper on 18th February, 1905. He passed through the ranks, Corporal 10th April, 1905, Sergeant 1st March, 1906, and was commissioned 2nd Lieutenant on 9th November, 1906 with promotion to Lieutenant on 21st January, 1906.<sup>7</sup> From 1st March 1910 to 1st February, 1911 he was provisionally appointed as Militia Adjutant of the regiment during which time he was a candidate for appointment to the A. & I. Staff of the A.M.F. Shown in Figure 1 is a reproduction of the mimeographed record issued by the regiment detailing service, examinations and schools of instruction completed with reference to the relevant district orders.<sup>7</sup>

His militia adjutancy was relinquished with appointment as Lieutenant on the A. & I. Staff (N.S.W.) on 1st February, 1911. At this time (4th February, 1911) he married Brenda Elsie, daughter of Julius Holland at St James' Anglican Church, Sydney. During the years 1910–1912 he attended instruction at the University of Sydney completing the Diploma in Military Science in September 1912.<sup>8</sup> The diploma was the first formal military qualification issued in Australia and existed between 1906 and 1916.<sup>9</sup> The course of instruction consisted of:

- Topography
- Military Topography
- Military Science I (Strategy and Military History)
- Military Administration and Law
- Military Science II (Imperial Defence and Military History)
- Military Science III (Tactics and Military History)
- Military Engineering

Other courses of instruction attended during the period at the School of Musketry (Randwick) were the Qualifying Course Permanent Forces dated 27th February, 1912<sup>10</sup> and the Qualifying Course (Maxim Machine Gun) dated 14th March, 1912.<sup>11</sup> Service continued on the instructional staff of 2MD until appointment adjutant of the 11th Light Horse (Goulburn) on 1st July, 1913.

With the declaration of War, Somerville first served as temporary GS03 2MD from 13th August until 19th November, 1914. The 6th Light Horse Regiment (AIF) 2nd Light Horse Brigade was formed during September 1914 at Sydney (Roseberry Park, Rosehill, Liverpool and Holsworthy) under the command of Colonel C.F. Cox, a former regimental commander in the War in South Africa and Somerville commenced AIF service as Captain and Adjutant of the regiment on 20th November, 1914.<sup>12</sup>

The 6th Light Horse embarked Sydney on the Troopship *Suevic* on 21st December, 1914 and arrived in Alexandria on 1st February, 1915 and proceeded to Maadi Camp. Training continued until 15th May when the regiment embarked for Gallipoli on the

vessel *Lutzow*. The 6th ALH arrived on 19th May and landed next day.<sup>12</sup> Somerville continued as adjutant until 15th October, 1915 with temporary promotion to Major effective 29th May, 1915. The regiment proceeded to the Nek on 22nd May and saw service for 28 days, while during early July it served at Holly Spur (Ryrie's Post).

A career as a Staff Officer commenced at Gallipoli with appointment as DAA and QMG 1st Aust. Div. AIF and promotion to Major on 1st October, 1915 with promotion to substantive Captain A. & I. Staff on 1st December, 1915. Mentioned in despatches<sup>13</sup> and severely wounded by shrapnel in the left hand he was evacuated to Egypt on 3rd December, 1915 resuming duty as DAA and QMG on 8th March, 1916. A short period of operation with the Egyptian Expeditionary Forces (19–29th March) preceded service with the British Expeditionary Forces in France and subsequently Belgium which continued from 5th April, 1916 to 18th November, 1918.

The Post as DAA and QMG (1st Aust. Div.) continued until 13th October 1916, at which time he accompanied Sir Neville Smyth, VC when he assumed command of the 2nd Australian Division. The new appointment was as AA and QMG with the rank of Lieut.-Col. (General list) AIF and honorary Lieut.-Col. AMF. Promotion to brevet major AMF for meritorious service occurred on 24th September 1917, from 6th December 1917 to 18th November 1918 the appointment of AQMG (HQ Aust. Army Corp) was held first under the command of Sir William Birdwood and later Sir John Monash.

With the Armistice, Somerville became Director 2nd Division Branch, Repatriation and Demobilisation Department in London. This appointment continued until 31st March 1919 when his AIF appointment was terminated with nomination, effective 1st April 1919 for admission to the Staff College, Camberley.

For service after Gallipoli in the European sector he was mentioned in despatches four times,<sup>14-17</sup> awarded the Distinguished Service Order (January 18, 1917), created a companion of the Order of St Michael and St John (January 19, 1918) and the Croix de Guerre (April 20, 1919) was conferred by the King of the Belgians.

The Somerville family, his wife and two daughters, one born after his father's embarkation, left Australia for London on the cargo vessel *MV Suffolk* during December 1918 and arrived in England in January 1919. The family including a daughter born in England embarked on the *SS Orvieto* on the 6th March 1920. Before returning to Australia he was sent by the High Commissioner for Australia to inspect and report on the maintenance of Australian War Graves in France and Belgium.

Success at Staff College was announced (24th April 1920) and the appointment of Chief Inspector of

Administration, Inspector Generals Branch Army Headquarters (SO 2A) was held for a year during which time he was a member of the Military Books and Forms Committee. Allocation to the Staff Corps in the rank of substantive major and with the brevet rank of Lieut.-Colonel dated from 1st May 1921 with appointment as SO2 G Branch HQ 3rd Division. This appointment was held until 30th June 1923 during which time he attended No. 1 Special Weapons Course SAS Randwick (27th November – 9th December 1922).

The final AMF posting of Colonel Somerville as (SO1B) temporary District Commandant and District Base Commancer (3MD) was held until resignation on the 12th November 1924. At this time he was transferred to the Unattached List 2MD, then to the Reserve of Officers as substantive Lieut.-Colonel (13th November 1929) and subsequently to the Retired list as honorary Colonel (3rd July 1938). He received the silver medal commemorating the Jubilee of the reign of King George V May 1935. Some 84 400 medals were issued throughout the Empire on this occasion while he subsequently received the Coronation Medals of King George VI (1937) and Queen Elizabeth II (1953).

During World War 2 he was appointed Deputy Director of Recruiting AIF Eastern Command effective 24th May 1940 and was subsequently transferred to Area Commandant Metropolitan until the AIF appointment was terminated on 28th April 1941. These appointments were particularly timely as Somerville effectively became Military Commandant of the civil establishment of which he was chief executive officer. The Sydney showground was a major recruiting and staging venue in NSW handling at one period 1000 recruitments a day<sup>21</sup> with during July 1940 some 6000 men in camp.<sup>22,23</sup>

The World War 2 service of Colonel Somerville was not gazetted but records show appointment as Deputy Director of recruiting AIF Eastern Command with effect from 20th May 1940.<sup>21</sup> Transferred to Area Command Metropolitan on 1st March 1940 and AIF appointment terminated 25th April 1941. The Army list of 1940 shows allocation as DDGES Q Branch AHQ effective 6th November 1939.<sup>24</sup>

The military profession was at a low ebb after the first world war and rather than stagnate Somerville sought alternative employment. The position of Secretary of the Royal Agricultural Society of New South Wales became vacant with the sudden death<sup>25</sup> of the secretary Mr H.M. Somer on 31st May 1924. The assistant secretary Mr E.J. Rafferty became acting secretary while the vacancy was being advertised.<sup>26</sup> The position attracted a great number of applicants including the pastoralist F.L. Martin who had been elected to the RAS Council in 1901, to a vice-presidency in 1916 and during 1920 was acting president during the absence of Sir Samuel Hordern.

The post was also strongly sought after by serving and wartime army officers, Sir John Monash having

declined to provide a recommendation for Ivan Mackay, later Lieut.-General Sir Ivan Mackay, and twelve other former army applicants.<sup>29</sup> The appointment was decided after an exhaustive ballot by the council at a special meeting held on 21st October 1924 with Somerville being successful by two votes.<sup>30-33</sup>

The society showed a preference to appointing a secretary and chief executive officer who would bring fresh ideas and insights to the position. At the time the society was desirous of obtaining adjacent land from the Army and it has been suggested that Somerville who was well regarded in military circles might be of more assistance than any of the other applicants, in these endeavours.

Somerville, while secretary, travelled widely, attending openings and judging many rural and interstate shows. Following this appointment the RAS passed through periods of great development although the show suffered badly during the depression period. Throughout his tenure the majority of the current buildings were constructed and the scope of the show broadened to include other than the traditional rural purists.

Colonel Somerville, in addition to effectively being organiser of the Sydney Show, largely acted as spokesman for the society on both administrative and technical matters and as such was widely and regularly reported in the popular press.<sup>34</sup> Professionally he was elected Fellow of the Chartered Institute of Secretaries in 1947.<sup>35</sup>

Soon after Somerville's appointment the Society commenced to assume the secretarial work of a number of breed societies. This began with the Jersey Herd Society and by 1929 five of the pedigree milk societies in addition to the Australasian Stud Book for Trotters were being administered. This work involved the recording and checking of the pedigrees of stud stock and the annual publication of herd books, from that time additional breed societies were brought under the aegis of the society. By 1953 the secretarial management of 38 organisations was being undertaken, this requiring the annual recording of 125,000 stud records while since the beginning of this involvement, some 1,325,000 entries had been made. Colonel Somerville became secretary or secretary-general of the majority of these societies including all dairy breeds, Beef Shorthorn Society, Clydesdale Horse Society, and the Sheep Breeders' Association.

The society's interests were diverse and not restricted to the promotion of animals. Education at all levels was fostered and during 1926 the society was involved in establishing the Junior Farmers Movement and Mr F.L. Martin, one of the society's vice-presidents was elected president.<sup>36</sup>

Completion of the Sydney Harbour Bridge in 1932 provided an avenue for celebration at a time when memories of the depression were vivid. While the suggestion of a combined show and government

funded exhibition foundered through lack of funds the society was active in the celebration arrangements. Five members of council served on a committee appointed by a public meeting organised by the Lord Mayor of Sydney to handle the arrangements for a week-long carnival while Somerville was nominated as one of the honorary secretaries of the committee.<sup>37</sup>

Somerville, for the society, was active in discussions with the Government concerning possible celebrations for the sesquicentenary of White Settlement in Australia. Meetings were held from February 1936<sup>38</sup> and two new buildings, The Commemorative Pavilion and The Manufacturer's Hall were funded by the Government for the 1938 celebrations. Somerville was also a member of the Government committee responsible for the general celebrations that were held.<sup>39</sup>

By 1954 Colonel Somerville was felt to have passed the stage where he could carry out his duties with his former energy and zeal. In January 1954 the Finance Committee of the Society was directed to consider the reorganisation of the society's administration and to recommend the appointment of a new Chief Executive. Lieutenant-General Sir Frank Berryman accepted the position and took up duties on 12th May 1954.<sup>40</sup> Colonel Somerville was retired on 1st June 1954 but was given an allowance in return for providing his successor with any assistance that might be required and he continued an active association with society affairs until his death.<sup>25</sup>

During his entire business career Colonel Somerville was involved in a variety of charitable and civic activities. He was active in the foundation of the Legacy movement in New South Wales. The movement was inaugurated in Hobart a few years after the end of the 1914-18 war by Major-General Sir John Gellibrand, one of the leaders of the AIF, with the intention of guarding the interests of other servicemen. In March 1923 he formed the Remembrance Club of Hobart which met weekly at luncheon. The success of the Tasmanian venture encouraged him to interest ex-servicemen in Melbourne and Sydney to form similar local organisation.

The task was assisted by Gellibrand calling on many officers who had served under his command or who were aware of his stature as a military leader. The first club bearing the name Legacy, The Melbourne Legacy Club, was formed in September 1923 due largely to the enthusiasm of Captain (later Lieut.-General) C.S. Savige. Savige and T.W. White, on business trips to Sydney, interested Lt-Colonel E. Hilmer Smith who in December 1925 proposed to a group of ex-servicemen, who met daily for lunch at the Imperial Services Club, that a club be formed.

The group included Lt-Colonel G.C. Somerville, Lt-Colonel A.W. Hyman, Colonel S. King, Lt-Colonel E. Hilmer Smith, Lt-Colonel E.O. Milne, Colonel A.H. Moseley, Capt H.G. Nobbs, Capt R.C. Shier, Lt-Col J. Scott, and Major W. Carter.



Most of whom subsequently played important parts in the development of Legacy in New South Wales.

Developments were rather slow and on the 10th June, 1926 a meeting was held at the Imperial Services Club. When it was decided to form the Legacy Club of New South Wales at the meeting, Somerville was elected Chairman and present were A.H. Moseley, A.W. Hyman, S. King, E.O. Milne, E. Hilmer Smith and K.M. Mackenzie who acted as initial temporary secretary. Apologies were received from Brig-General (late Lieut-General) G. Gordon Bennett who was to be the second president, J. Scott, R.V. Spier and W. Carter.

The formative meeting was held on 27th July, 1926 at Endeavour House, the Macquarie Street premises of the Royal Agricultural Society and Colonel Somerville was elected foundation president for the year 1926–1927. He subsequently remained as an active legatee, a trustee from 1935 until his death.<sup>41-44</sup> The stature of Somerville in the formative years of Legacy is evident by the presence and action of both the foundation president and the then current president, Mr Blaski in welcoming the Governor Lieut-General Sir John Northcott at the official opening of Legacy House Sydney on 8th July 1950.<sup>45-46</sup>

Another long standing association was with the

NRMA of which he was a councillor from September 1931 until his death. During this period he was a member of the board of management, a Director of NRMA Insurance Ltd and a councillor of the Automobile Association of Australia, being widely concerned with country roads.<sup>47-51</sup>

The depression years created a greater awareness of economic and political issues and nationwide right-wing extremist movements flourished. Colonel Somerville was a leading figure in the Old Guard, a conservative para-military organisation active in New South Wales in the early 1930s.<sup>44</sup> He was a committee man of the New South Wales Group of the Order of St Michael and St George under the chairmanship of Sir Robert Garran, a member of the council of The Royal Empire Society (now The Royal Commonwealth Society)<sup>52</sup> and served on the Government Committee concerned with the visit to Australia of HRH The Duke of Gloucester. He was also a member of the Union Club, The Imperial Services Club Sydney and

#### ENDNOTES:

1. Family Records and Statutory Certificates.
2. The National Bank of Australasia Ltd Brisbane, 9.4.1973.
3. Bank of New South Wales Sydney, 25.9.1973.
4. Westpac Banking Corporation Sydney, 2.2.1988.
5. Westpac Banking Corporation Sydney, 3.4.1988.
6. Brisbane Grammar School, 27.1.1988.
7. AMF Certificate of Service 10/265 (1910).
8. Diploma Military Service University of Sydney, 22.9.1912.
9. Minute Book Department Military Science University of Sydney (1906-1916).
10. School Musketry Randwick Certificate No. 19, 27.2.1912.
11. School Musketry Randwick Certificate No. 34, 14.3.1912.
12. Under Furred Hats. G.L. Berry, W.C. Penfolds & Co. Ltd Sydney (1919).
13. London Gazette Supplement No. 29455, 28.1.1916 Military Order No. 168 (1916).
14. London Gazette 2nd Supplement No. 29890, 2.1.1917.
15. London Gazette 2nd Supplement No. 30107, 1.6.1917.
16. London Gazette 2nd Supplement No. 30448, 25.12.1917.
17. London Gazette No. 31089, 31.12.1918.
18. London Gazette Supplement No. 29886, 29.12.1916; Commonwealth Australian Gazette No. 103, 29.6.1917; Sydney Morning Herald, 10.1.1917.
19. London Gazette Supplement No. 30450, 1.1.1918; Commonwealth Aust Gazette No. 57, 18.4.1918.
20. London Gazette No. 31275, 5.4.1919.
21. S.M.H., 25.5.1940.
22. S.M.H., 31.5.1940.
23. S.M.H., 5.7.1940.
24. Army List Commonwealth Australia 1940 p.1579, 1940.
25. The Grand Parade B.H. Fletcher RAS Sydney, 1988.
26. Country Life, 25.7.1924.
27. Country Life, 8.4.1927.
28. Country Life, 17.3.1933.
29. Citizen & Soldier, Ivan G. Mackay, I. Chapman. Melway Publishers Pty Ltd Melbourne, 1975.
30. S.M.H., 22.10.1914.
31. S.M.H., 23.10.1914.

of The Royal Sydney Yacht Squadron.

The illustration shows Colonel Somerville in uniform accompanied by his wife in Sydney during his World War 2 Service. He died on 20th May, 1959<sup>53-54</sup> in Royal Prince Alfred Hospital from Cerebral Thrombosis and was cremated at Northern Suburbs Crematorium. His three married daughters, Mrs Brenda (Dutchie) Backhouse (1912-21.10.1985), Mrs Joan McKillop (1915-) and Mrs Beryl Frances Holmes (1920-) survived him, his wife having passed away on 11th January 1950.

#### Medals

Commander of Order of St Michael and St George; Distinguished Service Order; 1914-1915 Star; British War Medal; Victory Medal; King George V Silver Jubilee Medal 1935; King George VI Coronation Medal 1937; Queen Elizabeth II Coronation Medal 1953; War Medal 1939-1945; Australian Service Medal 1939-1945; Croix de Guerre (Belgium) 1919.

32. Country Life, 14.11.1924.
33. Sydney Mail, 30.4.1930.
34. S.M.H. Card Index 12 Pages.
35. Chartered Institute of Secretaries Sydney, 1988.
36. Australasian, 17.7.1926.
37. Programme of Official Opening of Sydney Harbour Bridge and Celebration (March 19-April 1), 1932.
38. Sun, 8.4.1936.
39. Programme Sesquicentenary Celebrations NSW, 1938.
40. RAS Press Release, 18.3.1955.
41. History of the Legacy Club of Sydney. E. Hilmer Smith, The Legacy Club of Sydney, 1944.
42. History of the Legacy Club of Sydney. E. Hilmer Smith, The Legacy Club of Sydney, 1950.
43. The Torch a Picture of Legacy. M.H. Ellis. Angus & Robinson, Sydney 1957.
44. Legacy The First Fifty Years. M. Lyons. Lothian Publishing Co. Melbourne, 1978.
45. Programme Opening Legacy House, Sydney, 8.7.1950.
46. Souvenir Supplement to Bulletin of Sydney Legacy, 5.6.1986.
47. Open Road, 13.8.1931.
48. Open Road, 10.9.1931.
49. Open Road, 24.9.1931.
50. Open Road, 1.7.1959.
51. Automobile Association of Australia. Private Communications March - April, 1988.
52. Royal Commonwealth Society Priv. Comm. April, 1988. Detailed records of Society previously destroyed by fire.
53. S.M.H., 21.5.1959.

#### GENERAL REFERENCES:

- Who's Who in Australia, XV edition 1955. Sungrature Publications, Melbourne.
- Who's Who in Australia XVI edition 1959. Sungrature Publications Melbourne.
- The VC and DSO a Complete Record.
- Official History of Australia in the War of 1914-1918. C.E.W. Bean Vol. I, II, V, VI.

Neil Speed

## Oh! For a shower of information

This is a brief follow-up to Mr Fagg's article, 'The Neglected Digger Charles Joseph Ross (1857-1930)', *Sabretache*, Oct/Dec 1988. I have been researching Charles Ross for five years; in July 1984 I acquired a Mauser C. 96 (Broomhandle) 7.63mm self-loading pistol along with a holster stock. The whole unit was apparently intended as a presentation to Ross but for some reason I believe he never received it.

I am a collector of self-loading (semi-auto) pistols, and when this item became available in 1984 I acquired it for two reasons, the interest and challenge behind the inscription and the near new condition of the pistol. Gauging by serial number the pistol would have been made in late 1898/1900, the holster stock has a non-matching factory serial number to the gun (a difference of 300-odd), but there is a regimental marking of A35 stamped into the left grip plate of the pistol and on the comb of the stock which shows they have seen service life together. The presentation was possibly intended to take place late 1901 for it was in that year that Ross reached the rank of Major.

I find Ross a most fascinating individual; a film script of his life would require an Errol Flynn to play the part and as can be seen from Mr Fagg's narrative Ross was looked upon as an excellent Constable in the North West Mounted Police, but the first shadow comes across his character with the second last document in his police service record. The 1885 Riel Indian Rebellion was put down by a combined police/military action. Superintendent Herchmer was involved against the Indians and became a Commissioner around 1890. (See signature on Discharge, previous article). Ross had left the force in 1890, and in 1899, nine years later and after an exemplary record, a note in Herchmer's own hand to a Mr White on official note paper, 'The Office of the Commissioner' dated December 1899 (fig. 1) reads as follows:

'I notice that Charles Ross (along) with Otter is trying to get sent out to S. Africa. this is the man who behaved so badly going down the Yukon with Scarth, and gave as his reason for returning that he was used up with Rheumatism. He is badly wanted up there for the alleged robbery of a cache and I hope the Dept will not help him to get me.

L. Herchmer

You will see from the copy of the document that Herchmer had the habit of running some of his words together when writing. I have used (along) in lieu of being able to decipher Herchmer's writing.

What Ross was doing for the nine years between leaving the North West Mounted Police and the outbreak of the Boer War in 1899 I don't know, but the reference to the Yukon indicates that Ross was at the gold rush of 1896. Scarth was an Inspector of Police. But they are indeed strange words in the last line of the Commissioner's letter.

The last document in the Police Service Record is a typed reply from White to Herchmer dated 7 December 1899.

Dear Herchmer,

I have your note re Chas. Ross who has been mentioned in the newspapers as an applicant for service in South Africa. I saw the newspaper item, but have not seen anything of Ross, although I believe he was in Ottawa. Capt. Winter, now of the Foot Guards, who was with the Ottawa Company at Cut Knife, and appears to have formed a high opinion of Ross from what he saw of him when in the North West, called here about ten days ago to ask me if he would be safe in saying that Ross had a good record for service in the Police. I turned up his papers and found that he had been discharged with a 'Very good' character, and so informed Winter.

With regards to Ross going to South Africa, I did not give the matter a second thought for the reason that I knew there was no intention of sending another contingent. I will now make a point of seeing Winter and telling him (you) what you say of Ross.

Yours very truly,  
(White)

L.W. Herchmer, Esq.,  
Regina, N.W.T.

So here we have the transition; a nine-year break, but the two periods of Ross' life are connected by these two letters.

7<sup>th</sup> West Mounted Police,

Office of the Commissioner,

Regina, Dec 3<sup>rd</sup> 1898

Dear Mr. White

I believe that Charles  
Ross is sent to with other is by my  
to get sent out to Sapsara.  
This is the man who behaved so  
badly from down the Gaba  
with death, and gave as his  
reason for returning that he  
was made up with rheumatism.  
He is badly wanted up there  
for the alleged robbery of a cattle  
and I hope the Dept will not  
help him to get out  
Yours truly  
C. C. C. C. C.

As part of the papers that I have acquired over the period of research there is an interview in 1956 by Mr E. Pye, army historian (Canadian) with a Mr William A. Hare, a member of the Canadian Scouts. This reveals many interesting facts which beg a larger writing than this but here are a couple of interesting points.

In a telephone conversation last week, Mr Hare stated the Scouts were Canadian only in name, approximately only 15% being Canadians. The corps consisted of four squadrons:

- A—Canadian and American personnel
- B—Australian personnel
- C—A cosmopolitan squadron
- D—The 'Burgher Squadron' composed of renegade Dutchmen.

Following 'Gat' Howard's death in February 1901, command of the Scouts was taken over by Major Charles Ross — 'A Yank from Nevada, Calif.', a most capable officer who had seen much service as a scout in the U.S. Indian wars.

An in another section of the interview:

Probing for definite information regarding Ross, found Mr Hare extremely reticent. He explained that he would not divulge to anyone what information he had. (I gathered that some of the Scouts joined Ross in cattle rustling on a large scale.) He sometimes referred to Ross as 'Colonel'.

Asked whether they wore any special insignia, Mr Hare replied no. Their sole badge after 'Gat's' murder was a black feather, from which they became well known by the Boers. Everyone

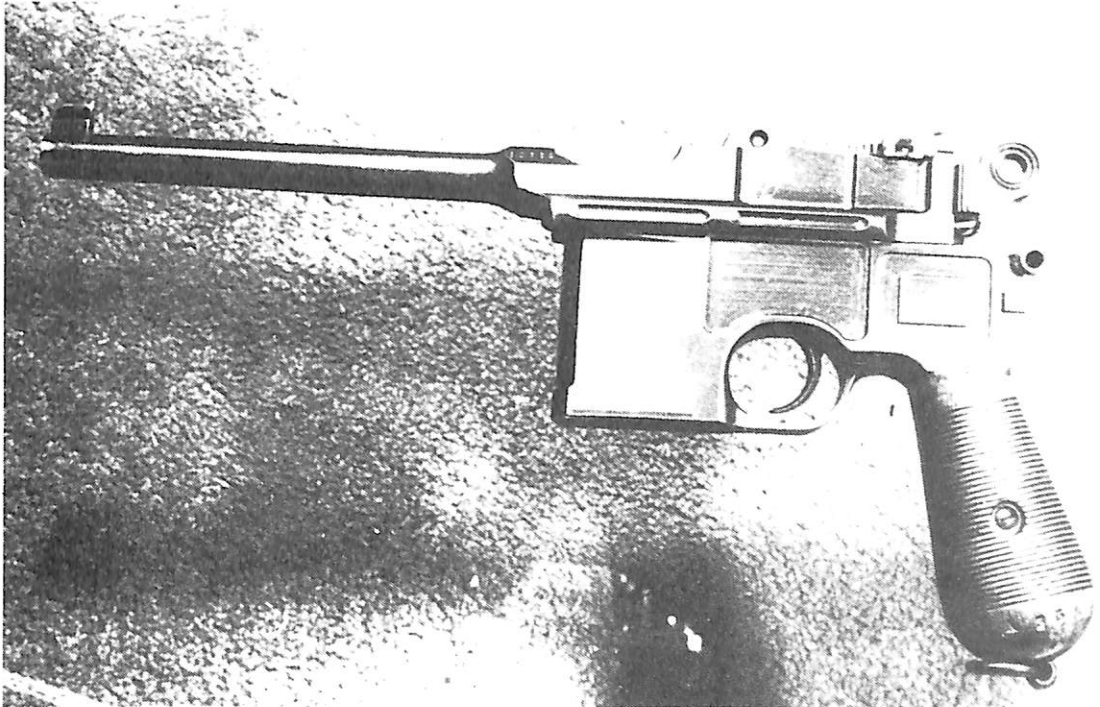

sought revenge for Howard's murder, the Scouts sought and gave no quarter; none was taken prisoner and they took no prisoners, said Mr Hare.

Caught unaware, Mr Hare implied that some of the Canadian Scouts were involved in the 'scandal in connection with the Imperial Cold Storage project'. (This may have a connection with the cattle rustling!)

It is reputed that 'Gat' Howard, out of his own funds paid his men a Sergeant's rate of pay so that they would not have to do guard duty; their emblem was a maple leaf with three chevrons over it to commemorate the fact.

When Ross took command of the Canadian Scouts there were circumstances similar to those of the Bush Veldt Carbineers and Morant; Howard, Commanding Officer of the Canadian Scouts was shot after surrendering and Ross on taking command had the Scouts swear to take no prisoners.

It would appear as if the alleged cattle rustling was

part of the scorched earth policy, one beast for the Army, one for Ross.

But all that I have uncovered in the past five years only leads me on to more questions; why did Herchmer fear Ross? I would dearly like to know details of the Imperial Cold Storage Scandal but above all my biggest question; the only mention that I can find regarding Captain C.A.R. Shower is on that pistol.

Who is he?

*He does not appear* in the Army List of the period; Ross does.

So who is Captain Shower?

#### ENDNOTES:

North West Mounted Police Service Record.

Interview taken by E. Pye with William A. Hare, March 5, 1956.

*The Boer War*, Thomas Pakenham. Weidenfeld and Nicholson, London.

The VC and DSO (until 1920) the late Sir O'Moore Creagh, VC, GCB, GSI, and EM Humphris (page 148).



A.F. Harris

## Wallace's Entrenching Tool in South Australia

In 1878 South Australia's Volunteer Military Force (VMF) was re-raised following its dissolution eight years earlier. It was to be a period of much military consideration in the colony, the analysis of which has been well covered by H. Zwillenberg's thesis previously published in this journal.<sup>1</sup> It seems that the military authorities in the colony kept themselves well informed on the numerous improvements and inventions of military arms and equipment during this period, and one item that came to their notice was a new entrenching tool.

The first mention of the tool appears to be in a memo sent to the Chief Secretary of South Australia by the VMF Commandant, Col. M.F. Downes, in July 1882. The memo covered a requisition for the purchase by the Agent General in London of 'Entrenching tools ... These tools have been invented and patented by Major Wallace and are adopted into the Imperial Service'.<sup>2</sup> The source of Col. Downes' information is not known. However, the date of the requisition suggests the tool was adopted by the British army two years before the date claimed by M. Chappell.<sup>3</sup> While Mr Chappell discusses (Slade-) Wallace equipment quite extensively, there is little detail about the tool itself. There is no mistaking the design though, as the sketch shown by Chappell shows all the features of the tool discussed here.

South Australia's indent was sent to the Agent General on 28 July 1882. Unfortunately, while we find that the entrenching tools were sent out in two cases at a cost of £61.10s.5d (plus a military advisor's commission, insurance, etc.), there is no indication of the number ordered.<sup>4</sup> The tools were shipped to the colony aboard the steamship *Rosetta* which berthed in Adelaide on 2 December 1882.<sup>5</sup> It seems that the tools were bought direct from the manufacturer, E. Lucas & Son, suggesting perhaps that they were not yet then available through the War Office. No doubt there was a considerable time-lag between the adoption of equipment and the subsequent supply or issue of the same.

While Chappell's illustration shows the tool carried in a frog suspended from the waist belt, the South Australian piece has been fitted with a locally made harness for carrying across the shoulder, and compris-

ing a shoulder strap/suspender, and a blade sheath. It is quite likely that the tools were bought without any means of carriage, as in similar cases, usually on the recommendation of the Agent General's military advisor, it was often considered preferable and more economical to have such accessories produced by local contractors. The leatherwork was made by a local saddler/coachbuilder Holden & Frost of Grenfell Street, Adelaide — later to become the Holden Motor company. All parts of the equipment, i.e. entrenching tool, blade sheath, and shoulder strap/suspender carry the government mark of a broad arrow over the initials SA — a mark that was widely used after 1878 on nearly all of South Australia's military arms and equipment.

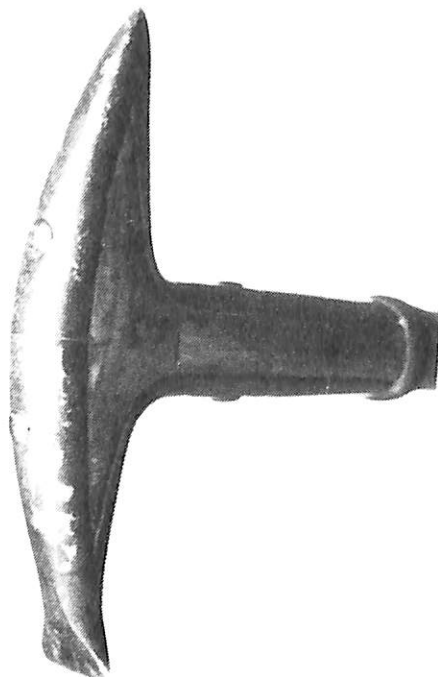

Handle of tool showing the pick and 'grubber'. Note the government property mark of 'broad arrow over SA' branded into the crosspiece.



*Entrenching tool as carried, with shoulder strap/suspender and blade sheath.*

The tool is exceptionally well made, with an ash handle and cross piece, and well fitted wrought, forged, and rivetted metalware. The blade is marked with the maker's stamp of E.L. & S. Sheffield, and acknowledges Wallace's patent. The point where the blade meets the shaft is shaped with a small protruding 'knuckle' to act as a point of leverage when digging. The curved cross piece is formed with a pointed pick at one end and 'grubber' at the other. The leatherware is light brown in colour, with a cast brass buckle to the shoulder strap and a brass button to secure the blade sheath strap.

Nothing is known of the issue of the tool to the members of the VMF. Presumably only so many per company or troop (of mounted rifles) were issued rather than one per man, but proportions of issue are neither known nor can be estimated as it is not known how many were bought. The entrenching tool shown was acquired from the family of an ex-member of the Mounted Rifles corps of the Volunteer Militia Reserve Force who served between February 1878 and April 1893. It is not known whether it was issued to him or if it was bought by him at a later surplus disposal sale or similar. However, the brown leatherware is consistent with the brown leather accoutrements then in use by the Mounted Rifles corps of the VMF (1878-86), South Australian Militia (1886-95), and Volunteer Militia Reserve Force (1890-95). Curiously, the leatherware has been marked in ink with what may be a price of 3s (3/-), which adds mystery to whether it was an issue or subsequent purchase. Fortunately the government mark verifies its military origins.

The author tends to the opinion that Wallace's entrenching tool was issued only to the mounted rifles in South Australia, not to any other branch of the forces, and that the shoulder sling was adopted as the most suitable means of carriage when on horseback. This being the only example of confirmed South Australian origin known to the author, and in the absence of any really detailed documentation on its acquisition, use, and disposal, there remain just as many questions, perhaps more, than answers found concerning this rather unusual piece of colonial militaria.

#### ENDNOTES:

1. H.J. Zwillenberg, *Soldiers and Citizens: The Defence of South Australia 1836-1901*.
2. GRG 24/6/1882 No. 1468, Public Records Office of South Australia (PROSA).
3. Mike Chappell, *British Infantry Equipments 1808-1908, Men-at-Arms Series*, Osprey, London, 1980.
4. GRG 55/1/20 p.863, PROSA.
5. Shipping Lists (Arrivals), PROSA.

Steve Duke

## Boer war transports and first world war shipping losses — a comparison

Readers will be interested to read the following short submission from Steve Duke, concerning the fate of some of the ships mentioned in John Price's 'Transports to South Africa 1899-1902' published in the previous issue of *Sabretache*.

**S**hips that carried Australian troops to Boer war. Comparison with similar named ships in world war 1 casualty lists.

Source: British merchant Shipping Losses WWI-NZ SHIP & MARINE SOC. Nov. 1966. Wellington.

- SS *KENT* attacked 12 Aug. 1918 by Sub. in North Sea —saved.
- SS *SURREY* struck mine 25 Feb. 1916 off Calais —saved.
- SS *CHICAGO* attacked by Sub. July 8, 1918 near Flamborough Head. Sunk. Three dead.
- SS *MANCHESTER PORT* attacked 4 June 1917, Atlantic —saved.
- SS *ARMENIAN* attacked 28 June 1915 near Trevoze Head. Sunk. Twenty-nine dead.
- SS *MANHATTAN 1*. 8,115 gross tons. 26 Jan., 1918 attacked by Sub. in Channel. Torpedoed but reached port. No dead.
- SS *MANHATTAN 2*. 8,004 gross tons. 25 Mar., 1917 west of Scilly Isles, attacked by Sub. gunfire and replied with own gun to escape.
- SS *CITY OF LINCOLN* torpedoed by Sub. 18 Sep., 1917 southwest of Scilly Isles but was towed to safety with loss of 9 lives.
- SS *CUSTODIAN* 20 Mar., 1918 Irish Sea attacked by Sub. and torpedoed but made it to port with loss of three lives.
- SS *BRITISH PRINCESS* 4 Mar., 1918 in Northern Irish waters, torpedoed by Sub. but reached port with only one dead.
- SS *BRITANNIC 1*. A hospital ship of 48,158 gross tons sunk with loss of 21 lives after striking a mine in "Zea" Channel on 21 Nov. 1916.
- SS *BRITANNIC 2*. 3,487 gross tons 30 Jul. 1916 20 miles ESE from Cape Bon. Captured by a Sub. using its gun.
- SS *ST ANDREW* hospital ship of 2,528 gross tons 25 Feb. 1915. 10 miles off Boulogne. Chased by Sub but escaped using speed.
- SS *ENGLISHMAN* 24 Mar. 1916. Captured and sunk by torpedo from Sub. with the loss of 10 lives 30 miles NE of Malin Head.
- SS *AURANIA*. Having survived an attack in June 1917 the Germans finally sunk her on 4 Feb. 1918 off Scotland with the loss of 8 lives. Torpedoed without warning.

As can be seen from this list and that of *Sabretache* Vol. XXX No. 1 these ships with a link to Australian history did not succeed in escaping from their fate. By looking at these few ships involved in Australia's short military history we have an example of the war at sea of 1914-18 in miniature. How many of those who travelled to and from South Africa on these ships were aware of their fate in the war to end all wars? What happened to those ships that did survive the First War? Can relics of these ships be found and brought to Australia? And does the fate of these ships not show the increasingly amphibious nature of modern total war?

I trust this information will spur others onto a search for the fates of other ships intimately involved with Australian military history. There is a huge hole in our knowledge of Australia's place in the history of maritime warfare the size of the proverbial "tinfoil". It's time for some damage control.

Readers wishing to correspond on any matters relating to any aspect of this are invited to write to the author C/o PO Box 340, Reservoir, Vic. 3073.

Paul Rosenzweig

## A relic of the *Geranium*

**R**eaders of Greg Swinden's article on *HMAS Geranium* may be interested to know of a surviving relic of her visits to Australia's northern coastline. During a waterborne reconnaissance of Melville Island's eastern coastline in 1985, members of NORFORCE's Water Operations Troop came upon a number of rusted iron poles and, nearer the cliff, a concrete benchmark bearing the ship's name and the year, 1927.

The *Geranium's* visit to the top end waters during the 1920s were part of a flurry of scientific investigations by the Commonwealth after South Australia rid herself of the troublesome and expensive territory.

The *Geranium* had first deployed in northern waters in 1921 as a hydrological survey vessel, a member of the RAN's newly created Hydrographic Branch. She was a frequent visitor to the top end,

adding considerable detail to the rather inaccurate charts of the day which attributed much information to the work of explorers of the previous century. One duty of such a survey vessel was the recording of the rise and fall of the tides at key locations, usually in reference to an established benchmark. To make benchmarks the ship carried quantities of cement, which occasionally sufficed for emergency repairs.

Soldier Point, on Melville Island's east coast, is a significant landmark for the Top End's sailing fraternity, its prominent red cliffs providing a welcome break in a coastline of saline plains and impenetrable mangroves. The rusting poles atop the Soldier Point cliffs would have been used for hauling the survey crew's gear ashore, as well as the cement for making the concrete block. This benchmark, although it does not appear on modern nautical charts, is a significant relic of the early days of the Northern Territory.



A NORFORCE patrol, undergoing seamanship training in Zodiac inflatables, comes ashore below the conspicuous red cliffs of Soldier Point, used as a landmark by members of the Top End's sailing fraternity.

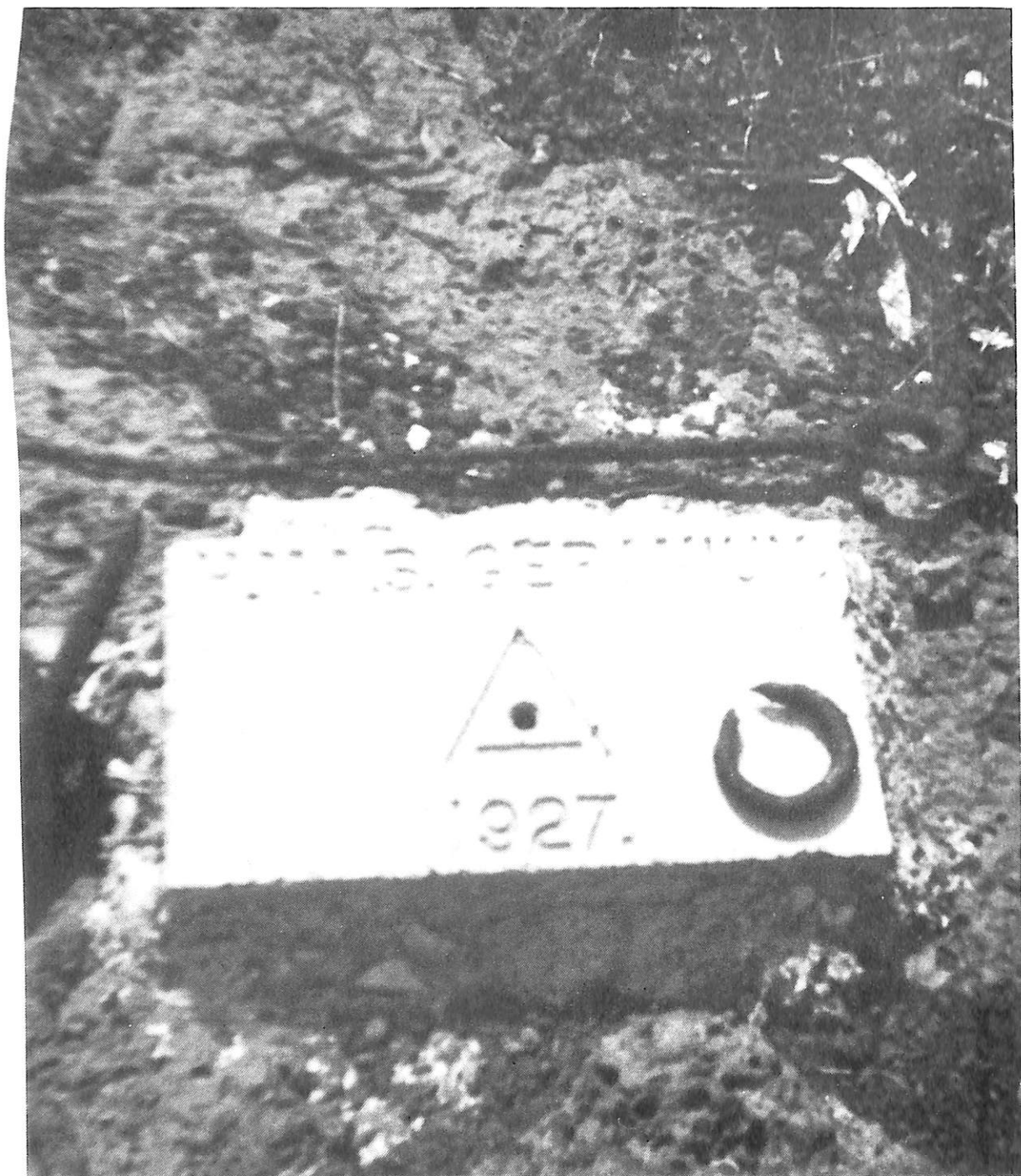

*The concrete benchmark and rusted iron poles left behind by HMAS Geranium after her 1927 visit to Melville Island.*

## Book Reviews

Jack Thurger and Charles Wright (compilers) 1988, *Welcome Home*. Austwide Communications Pty Ltd. A4 format, 160pp, price \$39.95 (post extra).

This book — published, printed and sold by Vietnam Veterans — is an historical record and pictorial of the Vietnam veterans' Welcome Home Parade held in Sydney, 3 October 1987. It is simple in format for it is basically a compilation of hundreds of photographs (both colour and black & white) taken at the Welcome Home activities. With the exception of two pages of photographs of VC winners and relatives the remainder are uncaptioned and individuals are unnamed. For future historical purposes some naming of individuals would have been of value. However one can appreciate the difficulty of naming faces in a crowd. The Vietnam Veterans will recognise many involved, for other readers the photographs say it all through the emotions captured; the joy, the sorrow, the mateship, and most of all the pride. And justified they are in having that pride despite the past actions and lack of recognition by a small but vocal minority of Australians.

Though the book is primarily a photographic record, for the historian it also contains the Roll of Honour of Australian service personnel who died in the war, together with full texts of congratulatory messages from Prime Minister Robert Hawke, Minister of Veterans' Affairs B. Humphries, US President Ronald Reagan, and the Parade Commander Major-General C. (Sandy) Pearson former 1 ATF Commander Vietnam 1968-69. Twenty pages are devoted to a brief but concise history of each unit involved in Vietnam and seven pages list the name and rank of recipients of service awards.

On 17 April this year a ceremony officially declared a site on Anzac Parade Canberra for the construction of a memorial in honour of those Australians who served and those who gave their lives in the Vietnam war. The major cost of designing and constructing that memorial will be borne by the Vietnam Veterans and to that end half of the \$39.95 purchase price of *Welcome Home* will go directly to that memorial fund. The book is sold through some bookshops (such as the Australian War Memorial Bookshop) and mail orders can be obtained directly from the publisher, Austwide Communications Pty Ltd, PO Box 583, Fyshwick, ACT 2609.

For those who have an interest in the military history of Australia's involvement in Vietnam this book makes a significant contribution to the unique social aspects of the home front as well as providing useful historical documentation in the one volume. For readers who may not have a direct interest in the Vietnam conflict I recommend you buy the book anyway, it will help the veterans build their memorial, and they deserve it.

**COLIN SIMPSON**

Bob Nicholls, *The Colonial Volunteers: The Defence Forces of the Colonies, 1836-1901*. Allen & Unwin, Sydney, 1988, pp. xviii + 215, including illustrations, tables and index. Hardback. Recommended price \$29.95.

This book is an important contribution to Australia's pre-Federation literature on the nation's naval and military forces. It was an era too before air forces had come into existence to share the Defence arena with the navy and the Army and to demand that 'The Frocks' as Field-Marshal Sir Henry Wilson used to call them, make adequate provision in the nation's Annual Estimates for their maintenance and development.

The qualifications of the author, Lieutenant-Commander Nicholls, for writing this book will be obvious to readers, not only by his professional knowledge and understanding of the technical, administrative and operational problems germane to a book of this character, but also because of his ability to analyse and explain them in writing with clarity, completeness and skill. This skill has extended to the enmeshing of the separate Naval and Military histories of each of the Australian colonies into one integrated narrative.

Another related feature of this book which should commend itself to readers is that it recognises that the Navy and the Army are each parts of a whole. The whole today is the Defence Force. No longer can the Navy and the Army be studied profitably by students of warfare, i.e. war ministers, officers of the Defence Force and others, as if they were separate forces with no necessary connections one with the other, except perhaps on rare occasions.

The author has produced a fitting record of the services rendered by the colonial volunteers in Australia before Federation. These services, generally speaking, were neither adequately recognised nor sufficiently appreciated at the time they were rendered, by either politicians or the public. Not all defence ministers of that era had the enthusiasm, the experience, the interest and the understanding of Lieutenant-Colonel Sir Frederick Sargood of the Colony of Victoria. The Council of Defence in his time in the Colony of Victoria could be said to have been in the forerunner of the post-Federation Naval and Military Boards.

In Ashley H. Thorndike's *The Outlook for Literature*, the author opened one chapter with the question 'What is literature?' He then followed this question with another namely 'How is it selected from the great mass of printed matter?' In his answers to these questions he said: 'Much of this ['great mass'] is rejected in a day; no one reads it on the morrow. Some of it survives for a month, a year, or a decade, and then loses its hold on our attention.' The author then added 'Of what remains and is preserved. . . , much is of interest because of its scientific or historical value.'

Some readers may consider *The Colonial Volunteers* to be a book belonging to this last class mentioned by Thorndike. For the general reader it is an easy book to read and it is, although a relatively slender book, an authoritative and a ready source of information on its subject.

The book is recommended to readers interested in pre-Federation Australian defence history. It is attractively produced physically, and it is reasonably priced. Even the index is more efficient than some that I study from time to time.

**WARREN PERRY\***

\*Major Warren Perry, MBE, ED, MA(Melb), BEc(Syd). Sometime Federal President of the Military Historical Society of Australia.

## Members' Wants

WANTED: Details of known Western Australian QSA groups for an update of the publication *Western Australian Contingents to the South African War* by J. Burrige. The aim is to include as much detail as possible, i.e. WWI service and all suitable photographs, etc. I believe I have the complete roll of those who went on to serve in WWI but the odd man may have slipped through my fingers. All replies answered and confidentiality assured.

### WANTED

**1914-18 British War Medal  
to  
Australian 46th Bn**

**Victory Medals 1914-18  
to Australians  
30th, 47th, 50th, 51st, 60th  
Bns**

**MUST BE NAMED**

**Contact:**

**R.W. ELLIOTT  
210 Darcy Road  
Norman Park, Brisbane Qld 4170**

### Northern Historical Militaria New Australian Medal Reference Books

1. George, Albert & Edward Medals to Australians 1887-1984. \$25 + postage
2. WA Police Queen Victoria Diamond Jubilee Medal 1897. \$8 + postage
3. Qld Police Queen Victoria Diamond Jubilee Medal 1897. \$10 + postage

Postage at current surface parcel mail rates.

Books A4 size, card cover, recipient lists, historical detail, private publication.

Orders to:  
**NORTHERN HISTORICAL MILITARIA**  
Pollards Road, Rocky Cape  
Tasmania 7321

## Society Notes

**Members will be saddened to learn of the deaths of George Vazenry and A.E. 'Bert' Denman, both frequent contributors to *Sabretache*. Both members will be sorely missed.**

### Vale BERT DENMAN

Albert E. (Bert) Denman, a member of the MHSA and one of *Sabretache's* valued contributors, died at Murray Bridge, South Australia, in January of this year, aged 88.

Bert commenced his offerings to this journal in 1986, during my period as editor. Although an elderly man with no significant literary background, the editorial committee straight away took to his material — the clearly and modestly expressed experiences of an infantry soldier. Such genuine personal reminiscence of a first world war soldier is increasingly rare and valuable, the more so as much of Bert's writing concerned training, recreational and personal relationship topics infrequently covered by writers on military matters. And he always emphasized that his writing only covered events in which he was personally involved.

Enlisting in the AIF at 17, having put his age up 10 months, Bert served with the 51st Battalion in France from March to August 1918, ending his war recovering from the effects of mustard gas. He returned to Australia two days after his 19th birthday. He was commissioned in the 1939–45 war, serving in the Middle East and a number of locations in Australia on infantry training duties and garrison command. He left the army in 1947, his military connection totalling some 20 years, including militia and cadet service, and was awarded the Efficiency Medal.

Bert was always active in the Murray Bridge area, farming between the wars and later entering business. He was a keen sportsman and served on the Bench for many years as Justice of the Peace and Coroner. Altogether, his was a splendid record of service to his country and to his community.

As editor of this journal, I greatly valued Bert's contributions and the friendly letters which passed between us. I regret that I never did meet him.

If he did a great deal for *Sabretache*, his sister told me we did a lot for Bert, publishing the writings that so sustained him following the sad loss of his wife and the decline of his physical powers.

I believe we still hold a good deal of Bert Denman's output. I hope the editor will continue to publish what I and the editorial committee, and I think members of the Society, regard as valuable military history.

Alan Fraser

### Vale GEORGE (HANK) VAZENRY — 1922–89

Born in the USA, George enlisted for service in the Military Police during World War II. He served in Australia, where he was married in 1943, before participating in the Philippines Campaign.

George returned to America for discharge after the war and then returned to Australia. He enlisted in the Australian Army in 1951, serving initially with the Provost Corps but transferring to the RAASC in 1958, and later, RAAOC.

In 1968 George was posted to Central Army Records Office (CARO) and it was here that his interest in Australian military history enabled him to make his greatest contribution to the army and to the sum of military knowledge. As a warrant officer in charge of the CARO History Research Section, his unrivalled knowledge was widely respected by the Australian War Memorial in Canberra, the then Department of Repatriation, and many other official and ex-service organisations.

Retiring from the army in 1977, George joined the staff of the Military Secretary at Victoria Barracks, where his encyclopaedic knowledge continued to be sought. Apart from his military duties, George found time to write two notable works, 'The Military Forces of Victoria 1854–1967' and 'Historical Notes on Victoria Barracks to 1985'. At the time of his death, he had produced the draft of a book on the history of Australian colour patches.

When he reached pensionable age in 1985, his active employment with the Army, which, as soldier and public servant spanned over 33 years, came to an end and George started work as a security officer. However, his association with the army did not cease and his knowledge and advice continued to be drawn upon. He was also a valued contributor on military service details for the Australian Dictionary of Biography.

After courageously battling cancer for many months, George died suddenly on June 15, 1989. His great knowledge so readily given to other researchers will be greatly missed.

Our condolences are extended to his wife, Shirley, and his family.

D. Allan & J. Cossum



## MILITARY HISTORICAL SOCIETY OF AUSTRALIA NATIONAL SEMINAR, 1990

THE GEELONG BRANCH of the Military Historical Society of Australia will conduct a National Seminar and Public Exhibition over the Easter period, April 1990 — Saturday 14, Sunday 15 and Monday 16 at Geelong.

### AIMS:

- (a) To conduct a seminar for the members of the MHSA and to further individual contact between members.
- (b) To stage a public display of militaria, together with a display of military vehicles. A light horse re-enactment group and associated equipment and the historical re-enactment group.

### PROGRAM:

- A static display of militaria at the site of the seminar.
- Seminar on popular aspects of Society activities.
- Social evening.
- Visit to Fort Queenscliff, including:
  1. A tour of the Fort;
  2. Military Vehicle display;
  3. Light horse re-enactment group live display;
  4. Historical re-enactment group live display.
- Society shop selling MHSA books.

### TIMETABLE:

Friday	Interstate members arrive.
Saturday	9.00 am - 4.30 pm SEMINAR 7.30 pm - 11.00 pm DINNER
Sunday	9.30 am - 6.00 pm FORT QUEENSCLIFF, displays and picnic lunch. Evening — social evening for members and visitors.
Monday	9.30 am-12.00 pm FEDERAL COUNCIL MEETING, followed by Closing Address and general discussions.

### PROPOSED LOCATIONS (To be confirmed)

Saturday	National Wool Museum
Saturday evening	National Wool Museum
Sunday	Fort Queenscliff
Sunday evening	BBQ members home
Monday	National Wool Museum

### MHSA MEMBERS DISPLAY:

Any member wishing to bring specific items for displays are asked to inform us so we can organise display cases and security.



# **NAPOLEON'S MILITARY BOOKSHOP**

For a complete  
range of

- military books
- board games
- computer games
- fantasy
- miniatures

# **NAPOLEON'S MILITARY BOOKSHOP**

1 NORTH QUAY,  
BRISBANE 4000.  
(07) 229 1903

336 PITT ST.,  
SYDNEY 2000.  
(02) 264 7560

353 FLINDERS LA.,  
MELBOURNE 3000.  
(03) 62 3047

**THE MILITARY HISTORICAL SOCIETY OF AUSTRALIA**

The aims of the Society are the encouragement and pursuit of study and research in military history, customs, traditions, dress, arms, equipment and kindred matters; the promotion of public interest and knowledge in these subjects, and the preservation of historical military objects with particular reference to the armed forces of Australia.

**ORGANISATION**

The Federal Council of the Society is located in Canberra. The Society has branches in Brisbane, Canberra, Albury-Wodonga, Melbourne, Geelong, Adelaide and Perth. Details of meetings are available from Branch Secretaries whose names and addresses appear on the title page.

**SABRETACHE**

The Federal Council is responsible for the publication quarterly of the Society Journal, *Sabretache*, which is scheduled to be mailed to each member of the Society in the last week of the final month of each issue. Publication and mailing schedule dates are:  
Jan.-Mar. edition mailed last week of March  
Apr.-Jun. edition mailed last week of June  
Jul.-Sept. edition mailed last week of September  
Oct.-Dec. edition mailed last week of December

**ADVERTISING**

Society members may place, at no cost, one advertisement of approximately 40 words in the 'Members Sales and Wants' section each financial year. Commercial advertising rate is \$120 per full page; \$60 per half page; and \$25 per quarter page. Contract rates applicable at reduced rates. Apply Editor. Advertising material must reach the Secretary by the following dates:  
1 January for January-March edition  
1 April for April-June edition  
1 July for July-September edition  
1 October for October-December edition

**QUERIES**

The Society's honorary officers cannot undertake research on behalf of members. However, queries received by the Secretary will be published in the 'Notes and Queries' section of the Journal.

**SOCIETY PUBLICATIONS**

Society publications advertised in *Sabretache* are available from: Anthony Staunton, G.P.O.Box 1052, Canberra, A.C.T. 2601. Orders and remittances should be forwarded to this address.

**THE MILITARY HISTORICAL SOCIETY OF AUSTRALIA**

Please address all Correspondence to:  
The Federal Secretary, P.O. Box 30, Garran, A.C.T. 2605, Australia.

**APPLICATION FOR MEMBERSHIP**

I/We ..... of .....  
(Name, Rank, etc.) (Address)

.....  
hereby apply for membership of the MILITARY HISTORICAL SOCIETY OF AUSTRALIA and wish to be admitted as a  
\*Corresponding Member/\*Subscriber to *Sabretache*/\*Branch Member of the

..... Branch  
\*(Strike out non-applicable alternative)

My main interests are .....  
I/We enclose my/our remittance for \$26.00 (Aust.) being annual subscription, due 1st July each year.

